

Powered by

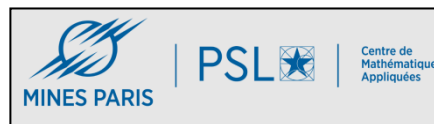

OPTIMAL MULTI-ENERGY MANAGEMENT IN SMART ENERGY SYSTEMS: A DEEP REINFORCEMENT LEARNING APPROACH AND A CASE-STUDY ON A FRENCH ECO-DISTRICT

D. Bousnina and G. Guerassimoff



Outline

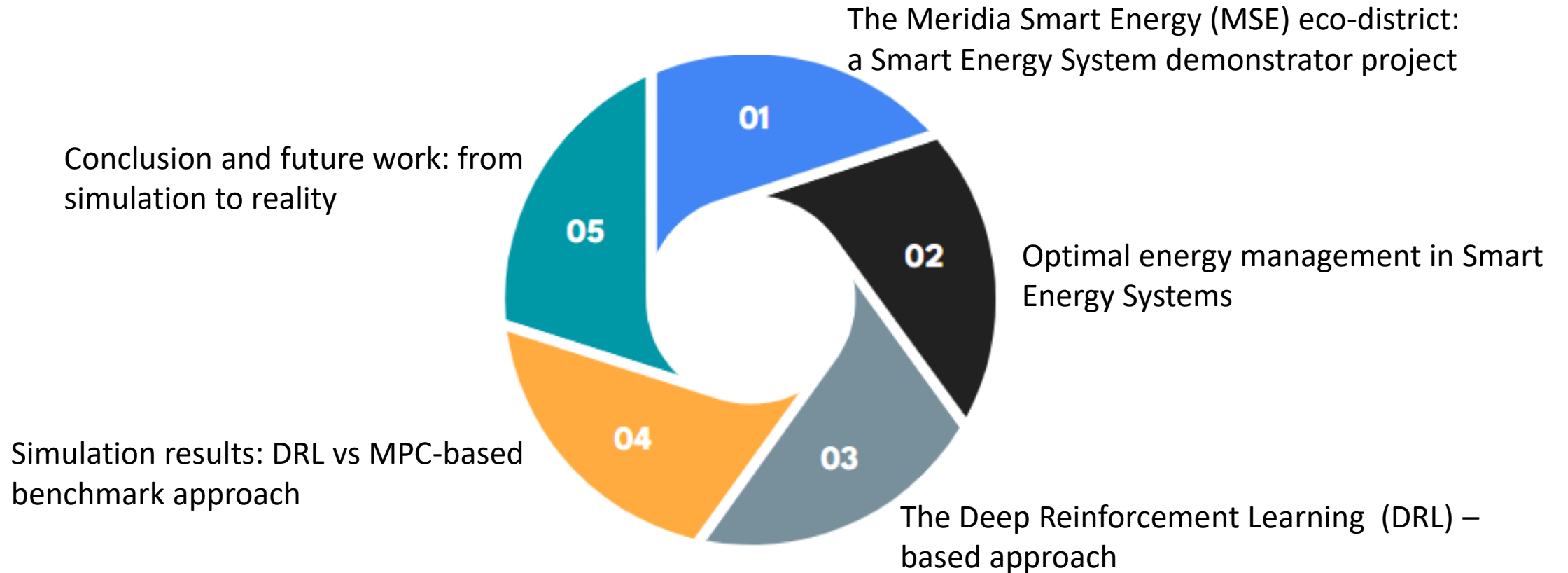



1- The Meridia Smart Energy (MSE) eco-district

Key project figures:

- ✓ 12 geothermal wells (30 to 40 meters deep)
- ✓ 11 MW of cold production
- ✓ 6 MW of heat production
- ✓ 3.5 km distribution network (5.6 km eventually)
- ✓ Heat, cold and electricity storage systems
- ✓ 8 connected buildings (50 eventually, eq. 3500 households)
- ✓ Over 70 % of renewables share in the overall energy mix of the SES

Consortium members



Project funder





2- Optimal energy management in Smart Energy Systems

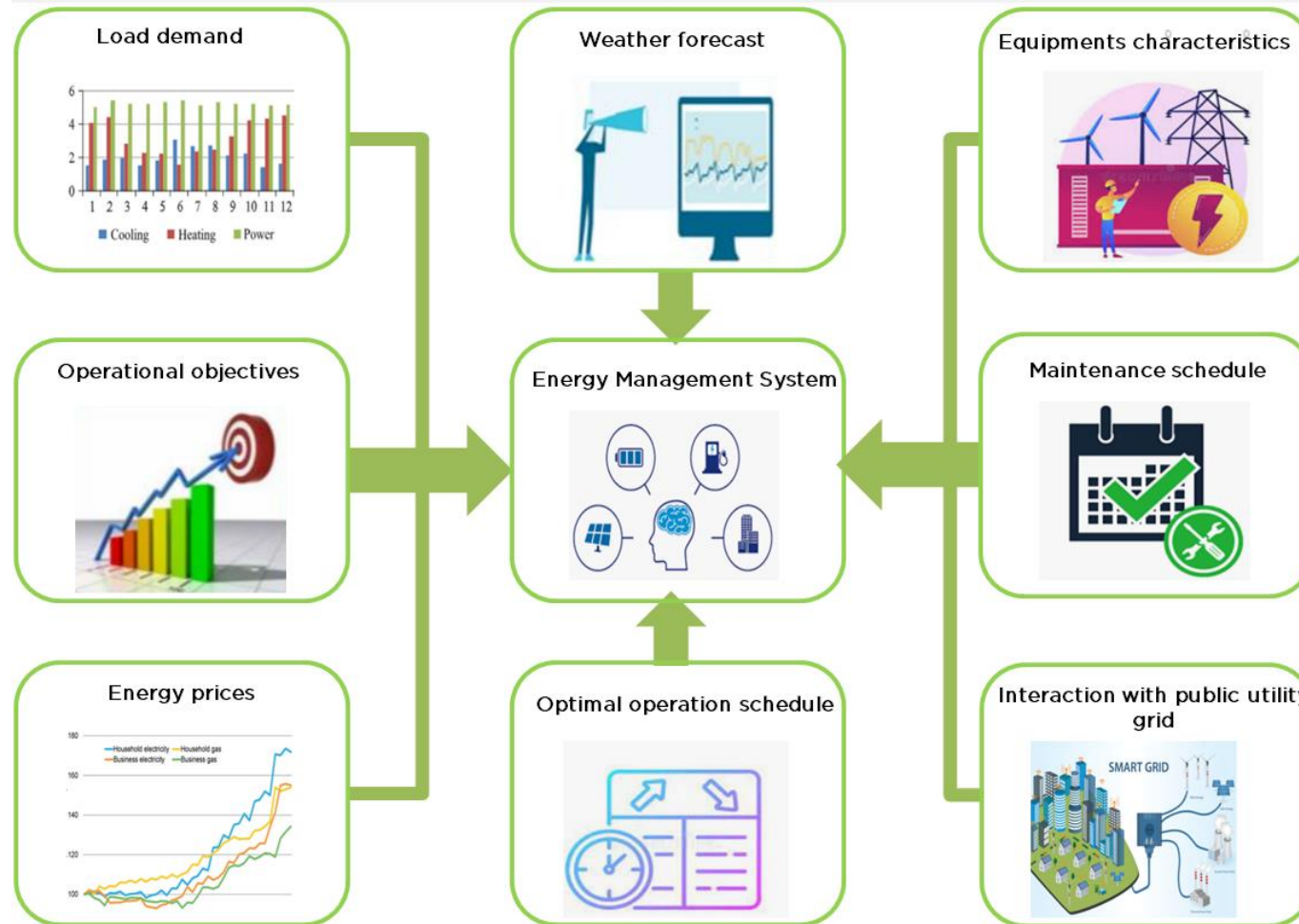

Energy management system framework (adapted from GU, Wei, WU, Zhi, BO, Rui, *et al.* Modeling, planning and optimal energy management of combined cooling, heating and power microgrid: A review. *International Journal of Electrical Power & Energy Systems*, 2014.)

2- Optimal energy management in Smart Energy Systems

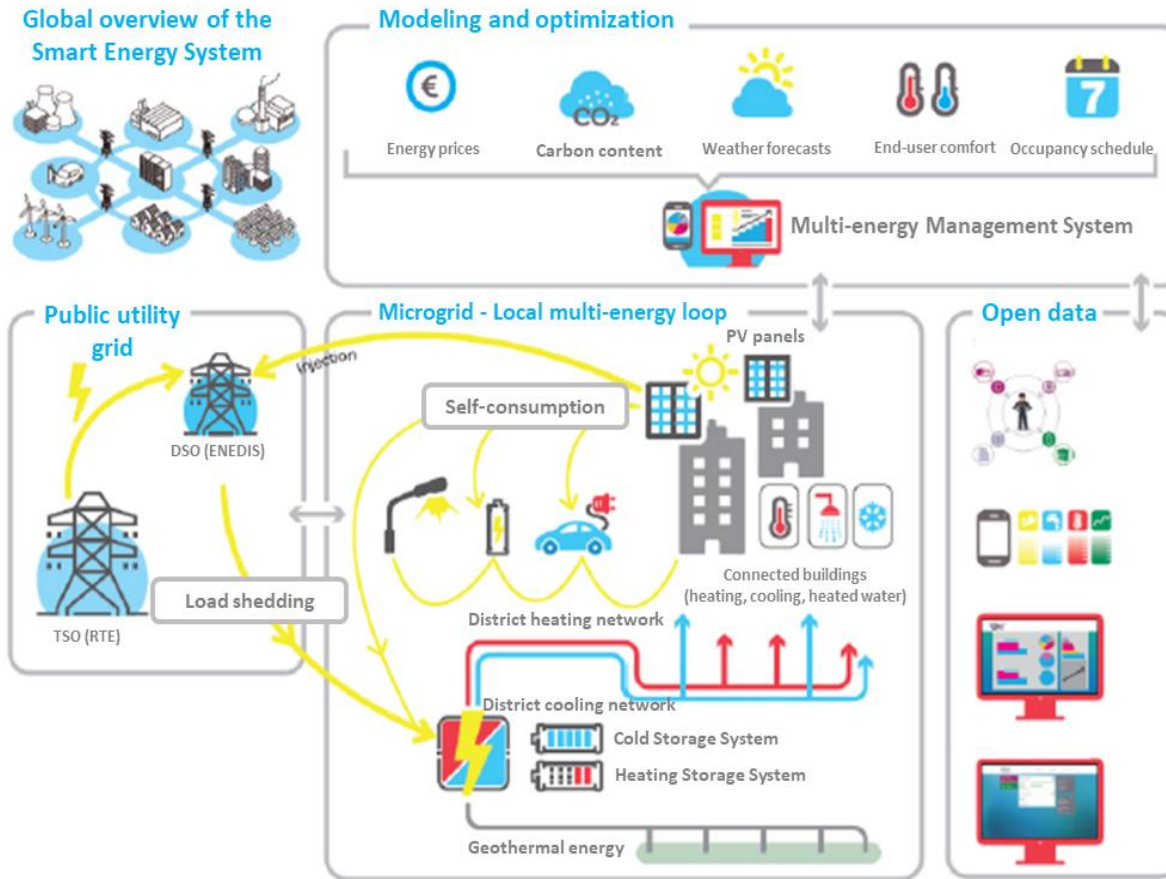

- A large amount of historical, online and operational data.
- A need for near-real time decision making (load shedding, frequency control, etc.).
- Traditional optimization approaches suffer from costly procedures: need for model, need to re-compute all parts of the possible solutions before choosing the optimal one.
- We propose an optimal energy management approach based on Deep Reinforcement Learning (DRL). A DRL agent, once it learns an optimal strategy, is capable of taking decisions within a few milliseconds.

Optimal energy management in the MSE Smart Energy System

3- The Deep Reinforcement Learning (DRL) – based approach

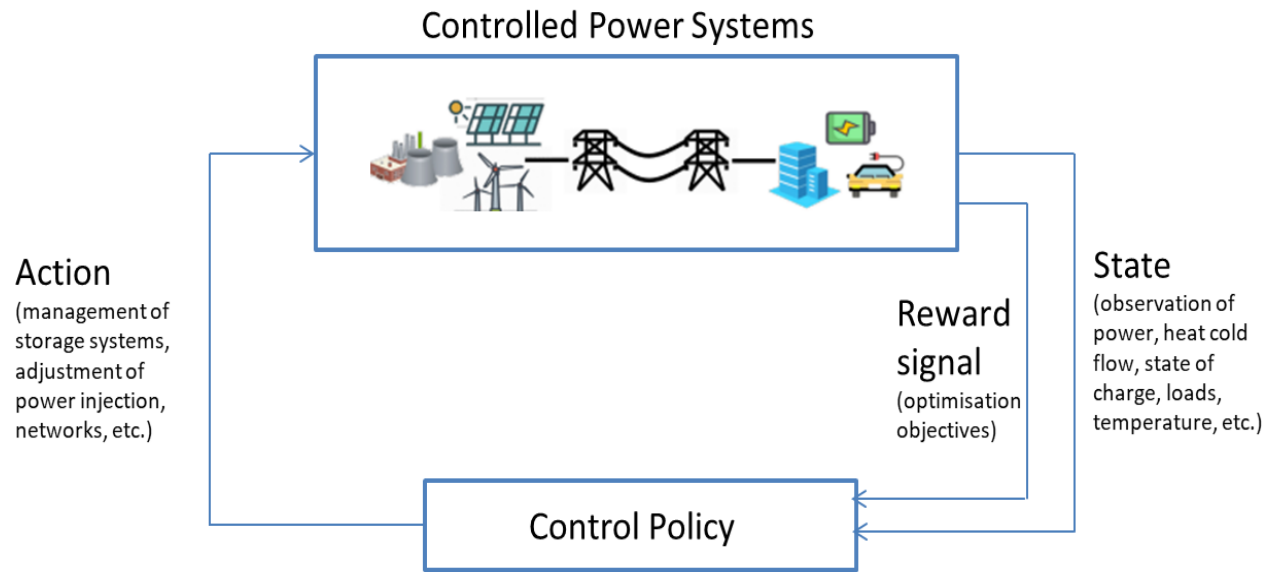

The RL scheme for power systems

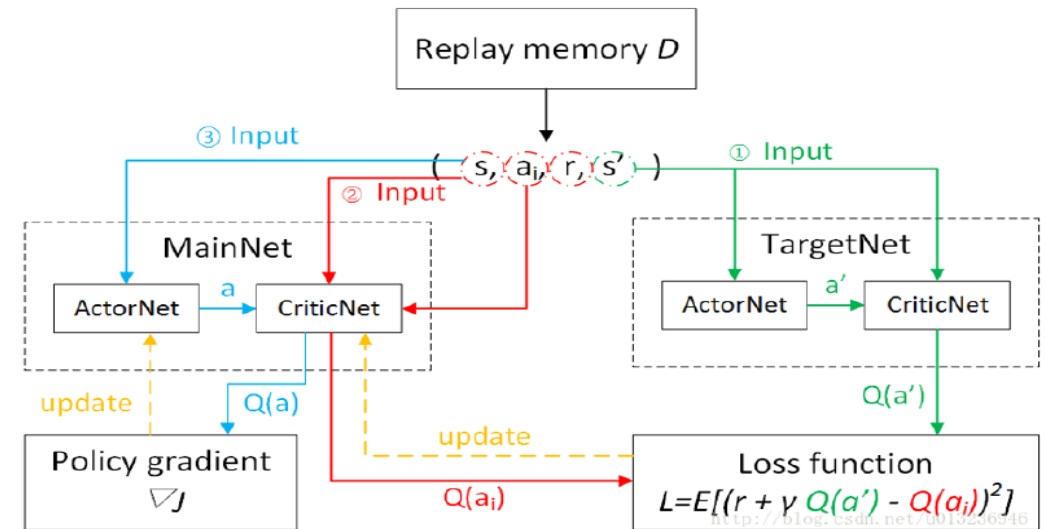

Actor-critic architecture of the DRL agent

3- The Deep Reinforcement Learning (DRL) – based approach

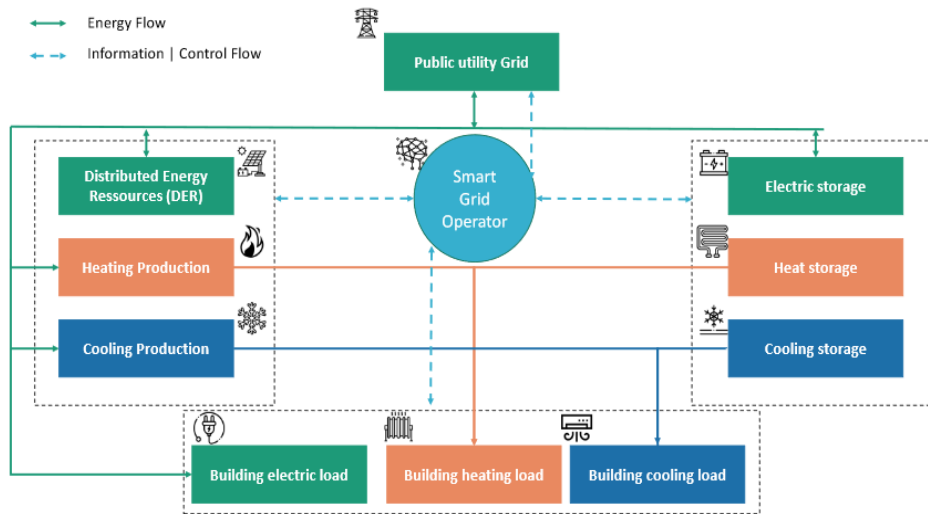

Architecture of the Smart Energy System simulator used as environment for the DRL framework

- **State space:**

$$s_t = (s_t^{Storage}, s_t^{Load}, s_t^{DER}, s_t^{Grid}, s_t^{Prod}, s_t^{Temp})$$

- **Action Space:**

$$P_t^{SS} = (P_t^{Bat}, P_t^{HS}, P_t^{CS})$$

- **Reward signal:**

$$r_t = -\alpha \cdot [C_t^{gen} \cdot P_t^{gen} + C_t^{grid} \cdot P_t^{grid}] + Penalty_t^{Bat} + Penalty_t^{hS} + Penalty_t^{CS}$$

$$Penalty_t^{Bat} = \begin{cases} -|P_t^{Bat}| & \text{if } \Delta SoC^{Bat} = 0, \\ 0 & \text{otherwise.} \end{cases} \quad Penalty_t^{hS} = \begin{cases} -|P_t^{hS}| & \text{if } \Delta SoC^{hS} = 0, \\ 0 & \text{otherwise.} \end{cases}$$

$$Penalty_t^{CS} = \begin{cases} -|P_t^{CS}| & \text{if } \Delta SoC^{CS} = 0, \\ 0 & \text{otherwise.} \end{cases}$$

4- Simulation results: DRL vs MPC-based benchmark approach

Architecture of the MPC-based benchmark approach

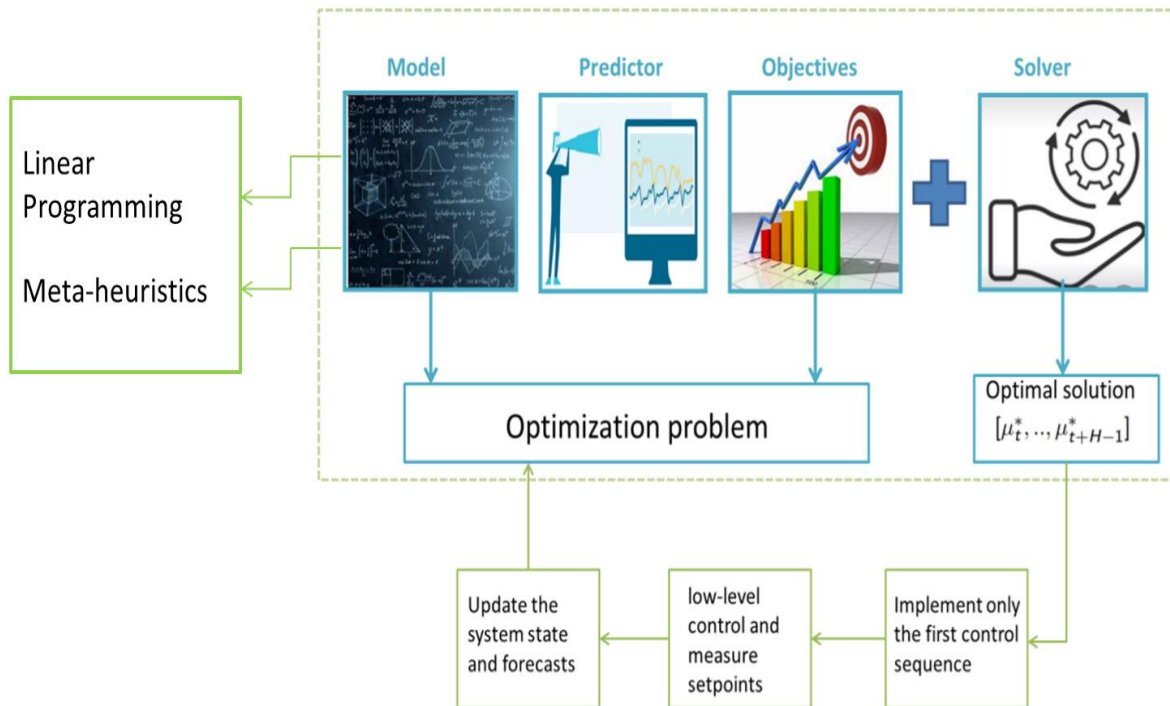

The optimization problem

$\min \sum_{t=0}^H C_t^{Gen} . P_t^{Gen} + C_t^{Grid} . P_t^{Grid} \quad (1a)$	Objective function
$\text{s.t. } P_t^{Grid} = P_t^{Load,e} + P_t^{Bat} + P_t^{pv} + P_t^{TRHP,e} \quad \forall t \quad (1b)$	Power balance equations of the SES
$P_t^{TRHP,h} = P_t^{load,h} + P_t^{HS} \quad \forall t \quad (1c)$	
$P_t^{TRHP,c} = P_t^{load,c} + P_t^{CS} \quad \forall t \quad (1d)$	
$P_t^{TRHP,h} + P_t^{TRHP,c} = COP^{TRHP} . P_t^{TRHP,e} \quad \forall t \quad (1e)$	Constraints of the battery storage system dynamics
$P_t^{Bat} = P_t^{Bat,ch} + P_t^{Bat,disch} \quad \forall t \quad (1f)$	
$E_1^{Bat} = E_{init}^{Bat} . (1 - k_{sd}^{Bat}) + \Delta t \left(P_0^{Bat,ch} . \eta_{Bat,ch} - \frac{1}{\eta_{Bat,disch}} . P_0^{Bat,disch} \right) \quad (1g)$	
$E_{t+1}^{Bat} = E_t^{Bat} . (1 - k_{sd}^{Bat}) + \Delta t \left(P_t^{Bat,ch} . \eta_{Bat,ch} - \frac{1}{\eta_{Bat,disch}} . P_t^{Bat,disch} \right) \quad \forall t \quad (1h)$	
$E_t^{Bat,min} \leq E_t^{Bat} \leq E_t^{Bat,max} \quad \forall t \quad (1i)$	Constraints of the heat storage system dynamics
$P_t^{Bat,min} \leq P_t^{Bat} \leq P_t^{Bat,max} \quad \forall t \quad (1j)$	
$P_t^{HS} = P_t^{HS,ch} + P_t^{HS,disch} \quad \forall t \quad (1k)$	
$E_1^{HS} = E_{init}^{HS} . (1 - k_{sd}^{HS}) + \Delta t \left(P_0^{HS,ch} . \eta_{HS,ch} - \frac{1}{\eta_{HS,disch}} . P_0^{HS,disch} \right) \quad (1l)$	
$E_{t+1}^{HS} = E_t^{HS} . (1 - k_{sd}^{HS}) + \Delta t \left(P_t^{HS,ch} . \eta_{HS,ch} - \frac{1}{\eta_{HS,disch}} . P_t^{HS,disch} \right) \quad \forall t \quad (1m)$	Constraints of the cold storage system dynamics
$E_t^{HS,min} \leq E_t^{HS} \leq E_t^{HS,max} \quad \forall t \quad (1n)$	
$P_t^{HS,min} \leq P_t^{HS} \leq P_t^{HS,max} \quad \forall t \quad (1o)$	
$P_t^{CS} = P_t^{CS,ch} + P_t^{CS,disch} \quad \forall t \quad (1p)$	
$E_1^{CS} = E_{init}^{CS} . (1 - k_{sd}^{CS}) + \Delta t \left(P_0^{CS,ch} . \eta_{CS,ch} - \frac{1}{\eta_{CS,disch}} . P_0^{CS,disch} \right) \quad (1q)$	Constraints of the cold storage system dynamics
$E_{t+1}^{CS} = E_t^{CS} . (1 - k_{sd}^{CS}) + \Delta t \left(P_t^{CS,ch} . \eta_{CS,ch} - \frac{1}{\eta_{CS,disch}} . P_t^{CS,disch} \right) \quad \forall t \quad (1r)$	
$E_t^{CS,min} \leq E_t^{CS} \leq E_t^{CS,max} \quad \forall t \quad (1s)$	
$P_t^{CS,min} \leq P_t^{CS} \leq P_t^{CS,max} \quad \forall t \quad (1t)$	



4- Simulation results: DRL vs MPC-based benchmark approach

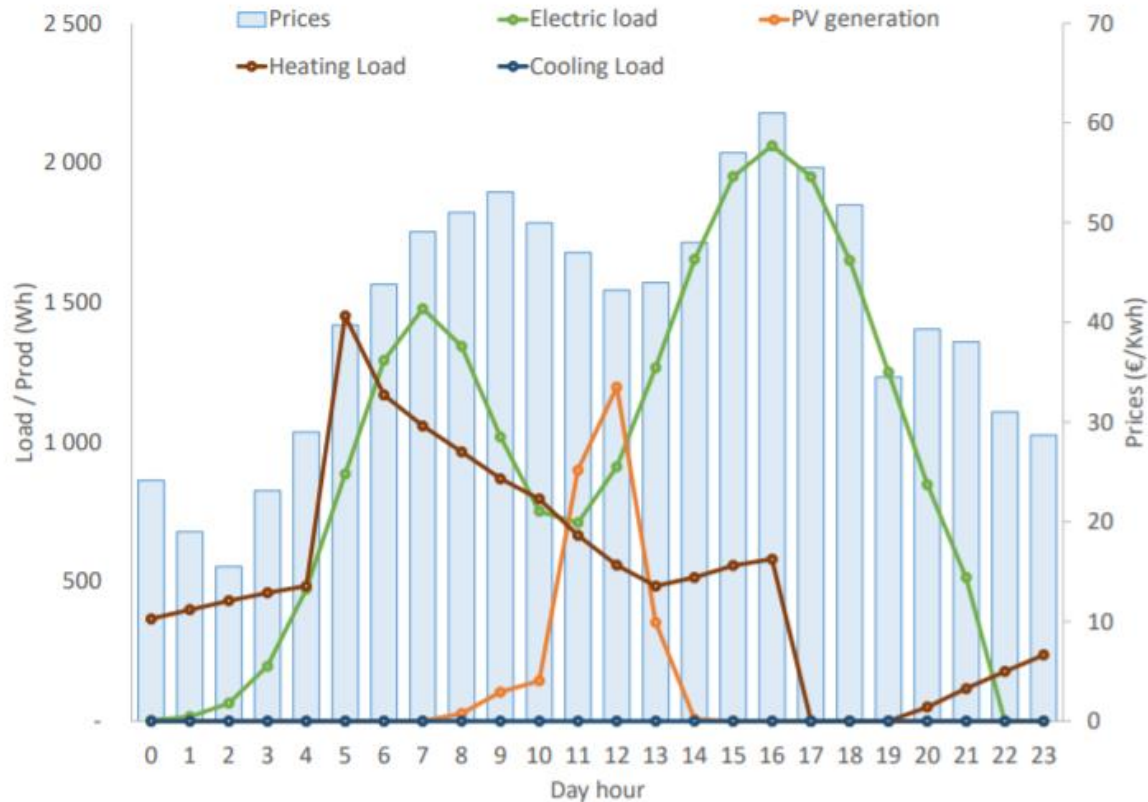

Visualisation of the data used for the simulations for a typical winter day

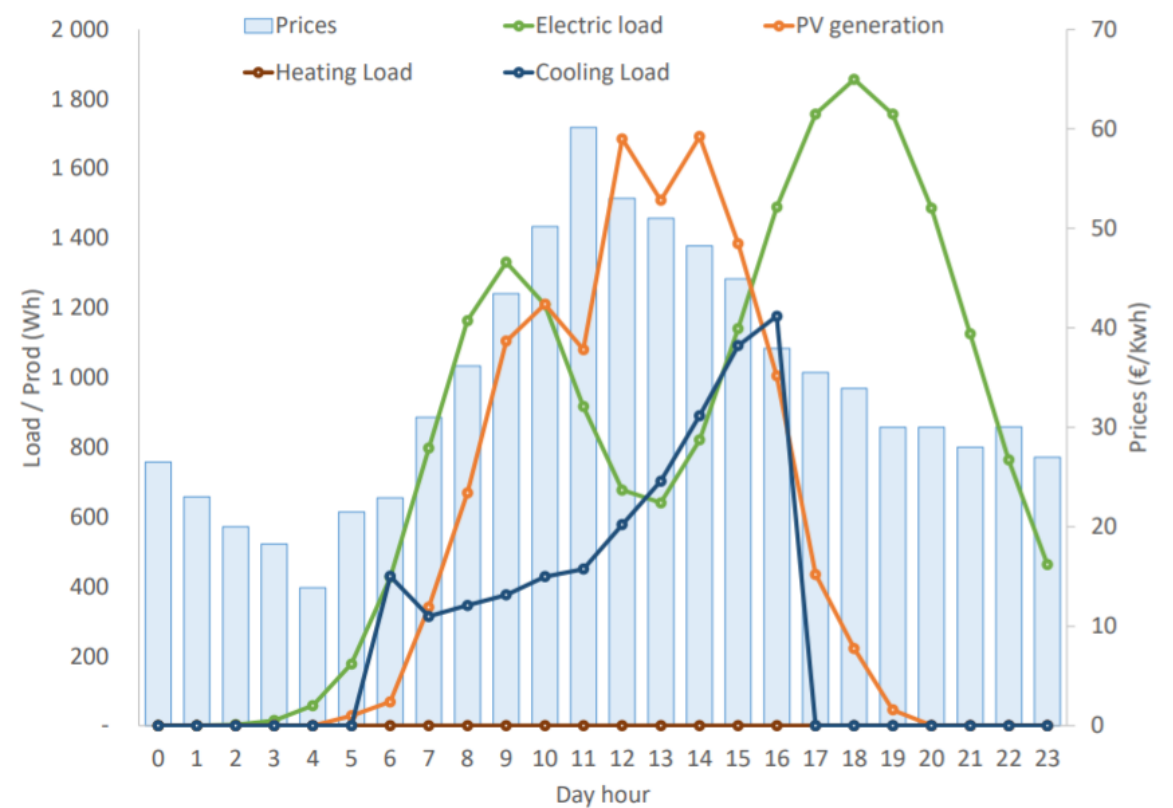

Visualisation of the data used for the simulations for a typical summer day



4- Simulation results: DRL vs MPC-based benchmark approach

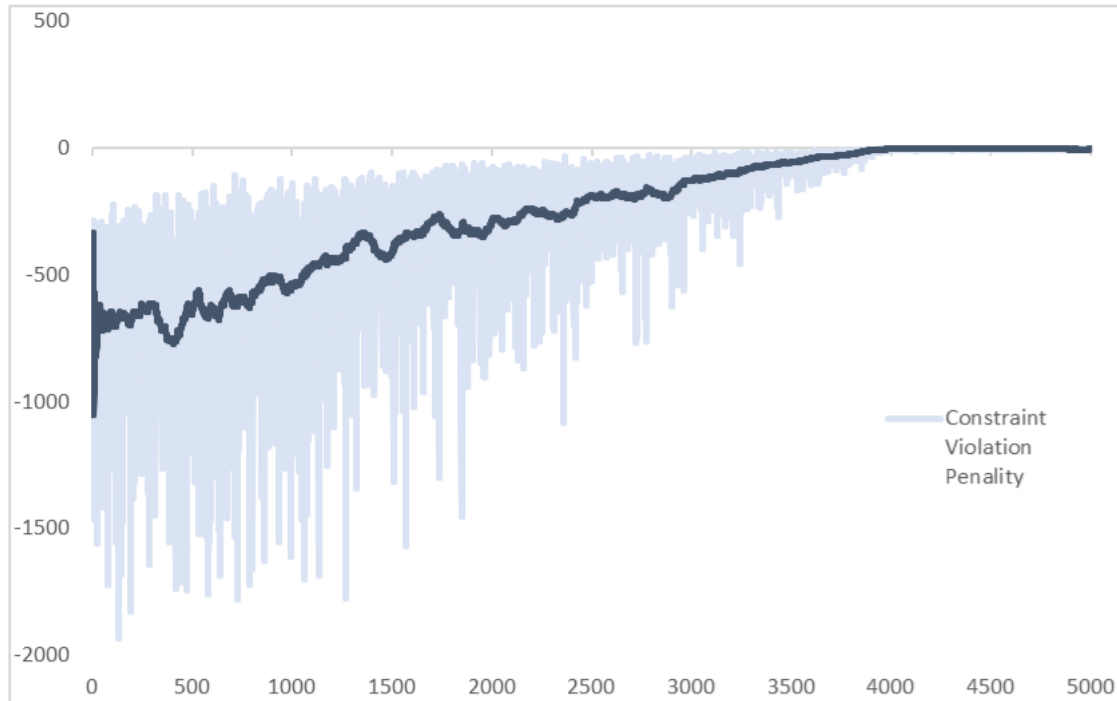

Evolution of the storage systems' constraint violation penalty component of the reward signal during learning

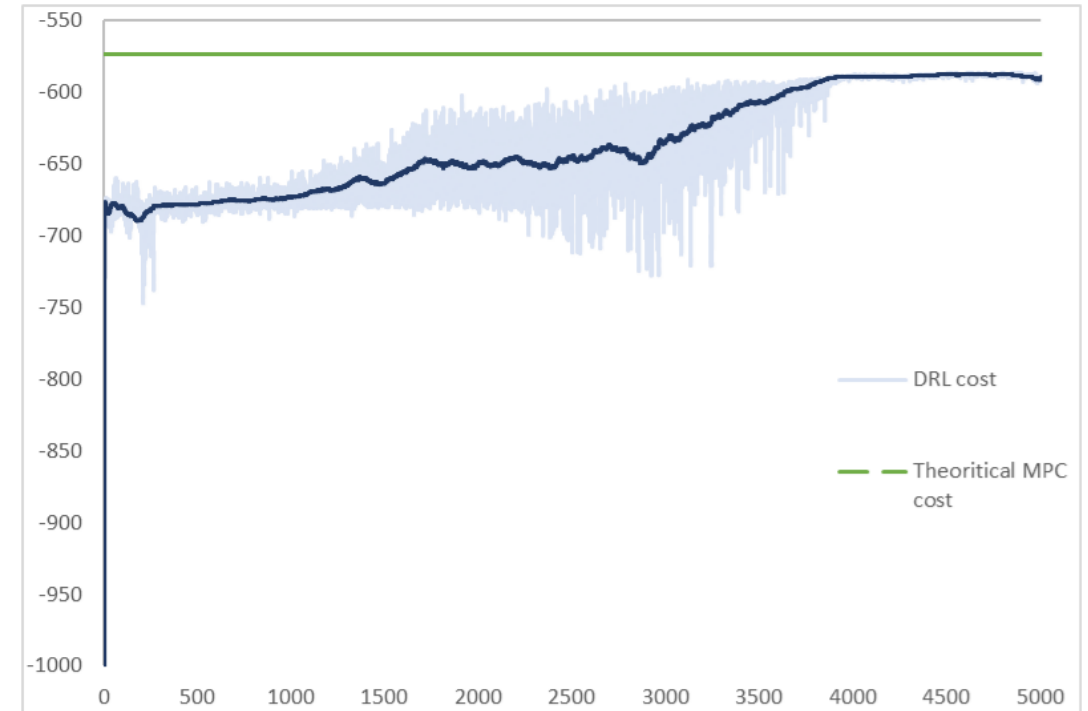

Evolution of the total operational costs of the Smart Energy System during learning, VS theoretical optimum obtained by MPC with perfect forecasts



4- Simulation results: DRL vs MPC-based benchmark approach

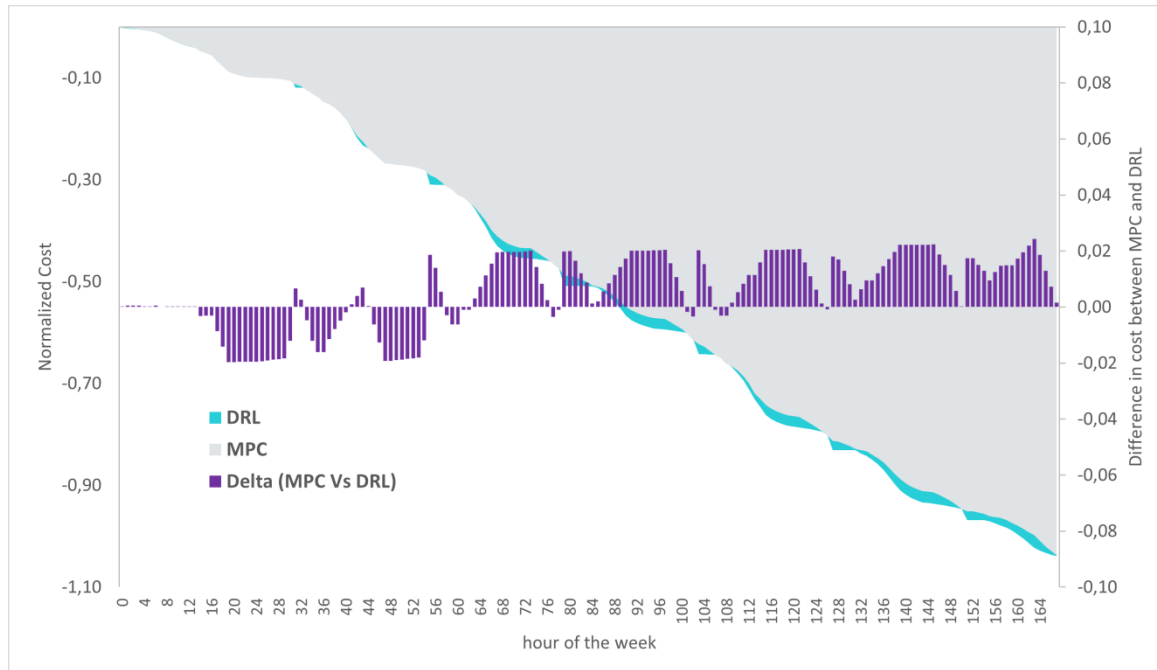

Cumulative normalized operational costs over one week of the DRL vs MPC

MPC with realistic forecasts
Adding noise to forecasts in the form :
 $F = F(1 + \varepsilon)$, $\varepsilon \sim N(0, \sigma^2)$

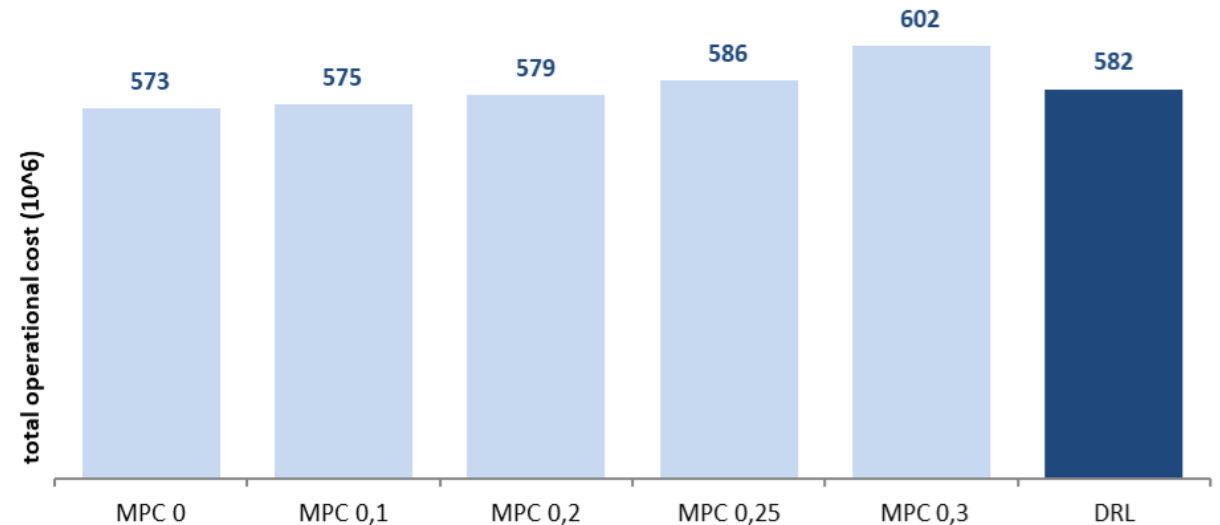

Total operational costs over one year obtained by the DRL agent versus different variants of MPC

Conclusions and future works

- ✓ Deep Reinforcement Learning (DRL) is a promising approach for optimal energy management of Smart Energy Systems.
- ✓ Effective parameter tuning and reward signal engineering are crucial for DRL's success. Notably, several research work report DRL challenges in managing storage systems. This failure likely stems from sparse reward issues.
- ✓ In this work, we addressed the sparse reward problem by enhancing the reward signal. The DRL agent succeeded in learning a strategy to proficiently manage electric, heat and cold storage systems.
- ✓ Simulation results on MSE case-study showcase comparable performance of DRL to Model Predictive Control (MPC) with perfect forecasts and superior performance to MPC under realistic forecasts.
- ✓ Future works include transitioning the developed DRL framework from simulation to real-world application on the MSE Smart Energy System, deploying it for the optimal multi-energy management as a decision-support tool

Powered by



THANK YOU FOR YOUR ATTENTION

D. Bousnina and G. Guerassimoff



4- Simulation results: DRL vs MPC-based benchmark approach

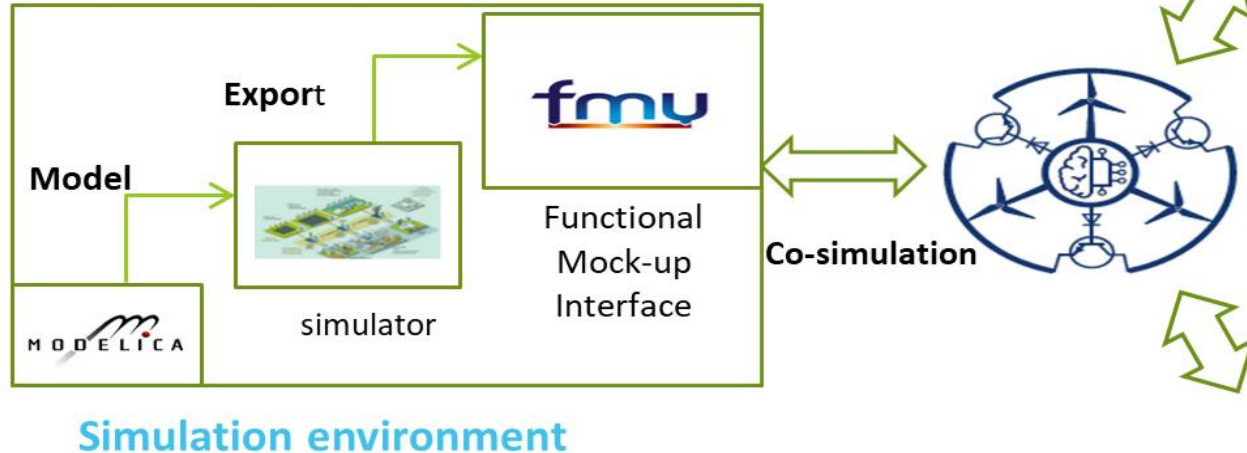
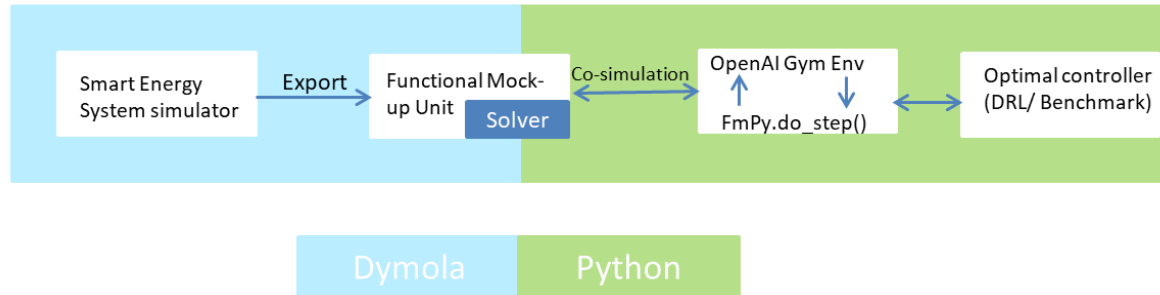

Deep Reinforcement Learning framework

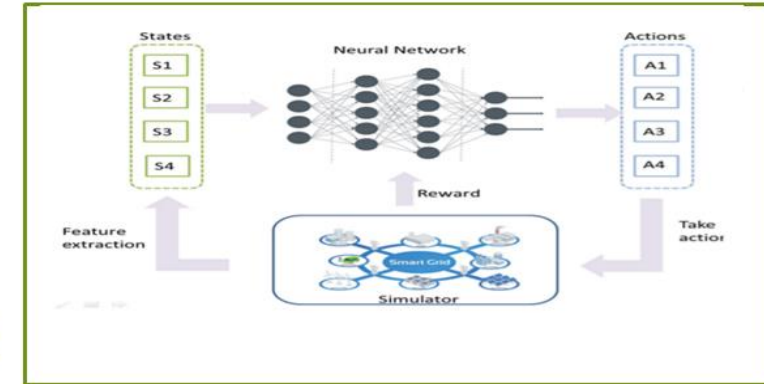

Test | Benchmark control approaches

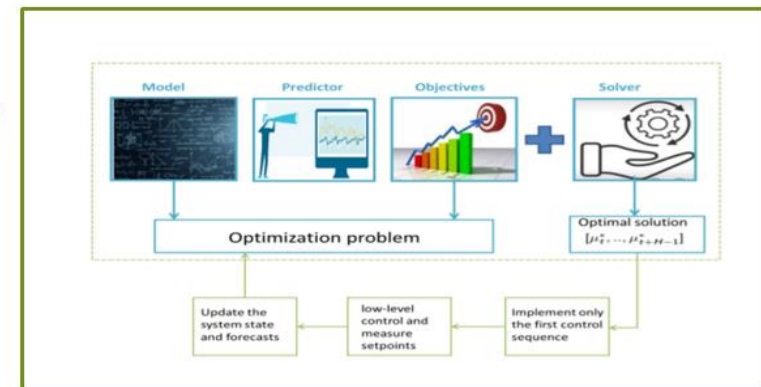

The multi-energy management framework developed in this work



4- Simulation results: DRL vs MPC-based benchmark approach

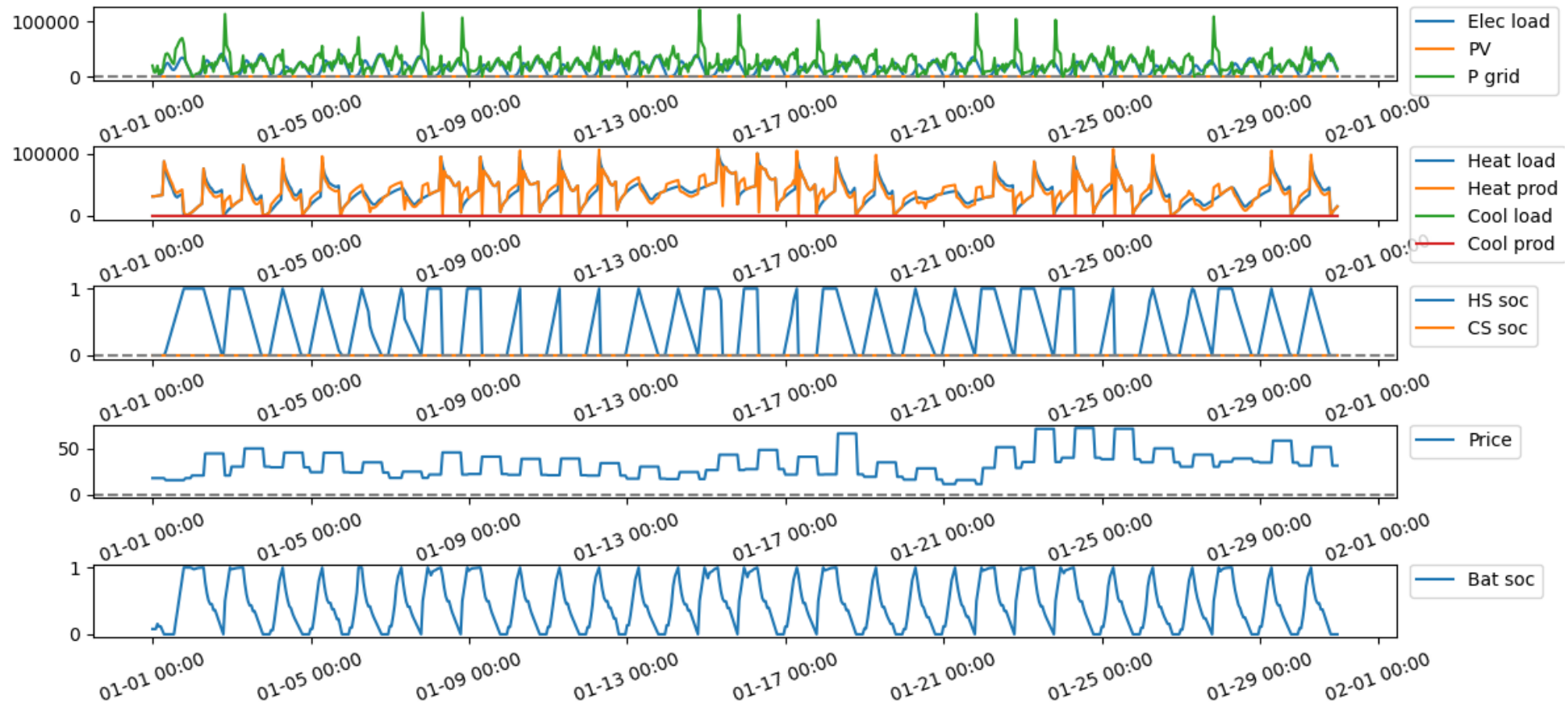

Example of MPC strategy over one month (winter)



4- Simulation results: DRL vs MPC-based benchmark approach

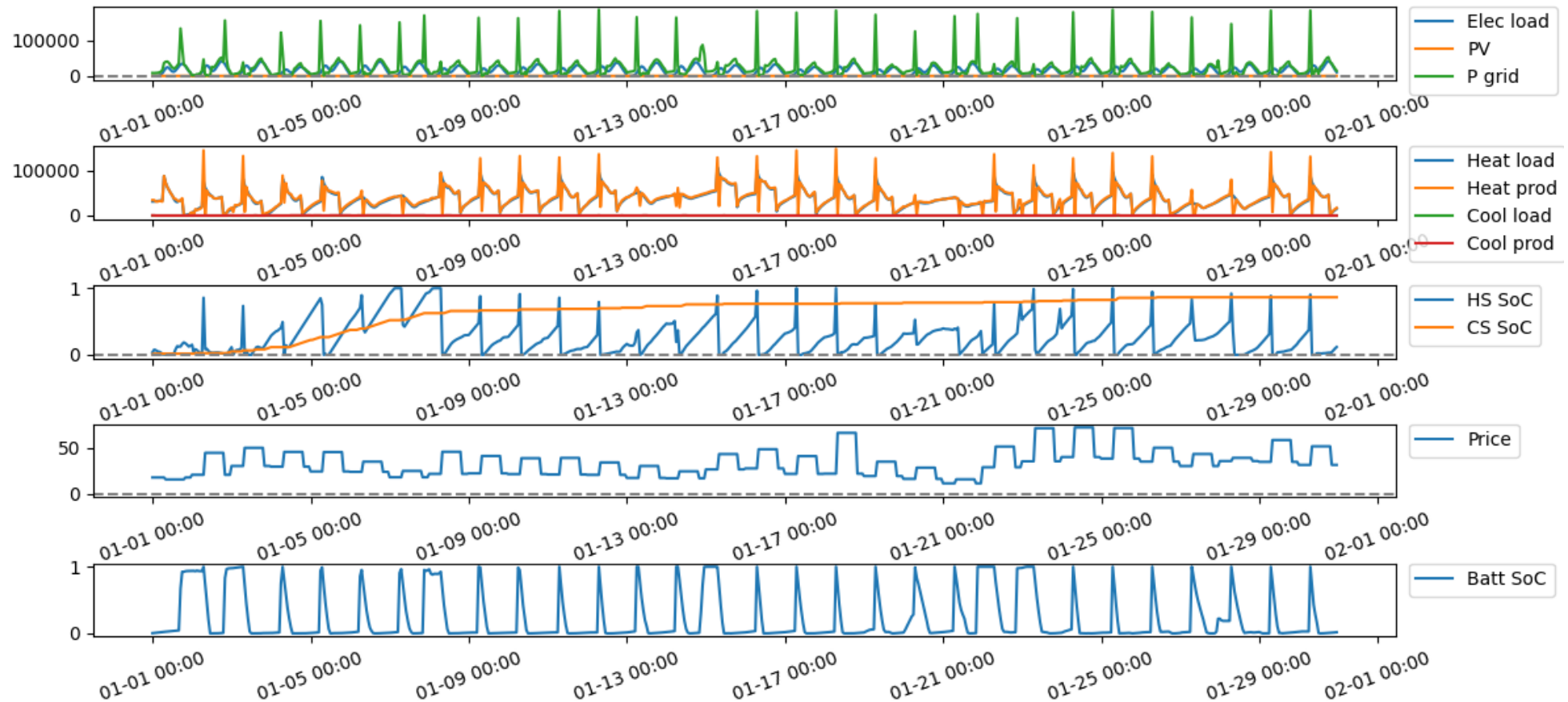

Example of DRL strategy over one month (winter)