



HAL
open science

The Digital Energy System 4.0 2016

Pieter Vingerhoets, Maher Chebbo, Nikos D. Hatziargyriou, Georges Kariniotakis, Rory Donnelly, Steven de Boeck, Anna-Carin Schneider, Anderskim Johansson, Stephane Dotto, Paul Hickey, et al.

► **To cite this version:**

Pieter Vingerhoets, Maher Chebbo, Nikos D. Hatziargyriou, Georges Kariniotakis, Rory Donnelly, et al.. The Digital Energy System 4.0 2016. [Research Report] European technology platform for the electricity networks of the future 2016, pp.72. hal-01411582

HAL Id: hal-01411582

<https://minesparis-psl.hal.science/hal-01411582>

Submitted on 7 Dec 2016

HAL is a multi-disciplinary open access archive for the deposit and dissemination of scientific research documents, whether they are published or not. The documents may come from teaching and research institutions in France or abroad, or from public or private research centers.

L'archive ouverte pluridisciplinaire **HAL**, est destinée au dépôt et à la diffusion de documents scientifiques de niveau recherche, publiés ou non, émanant des établissements d'enseignement et de recherche français ou étrangers, des laboratoires publics ou privés.



The Digital Energy System 4.0

2016



Authors and Contributors:

Main authors:

Pieter Vingerhoets, Working Group coordinator
Maher Chebbo, ETP SG Digital Energy Chair
Nikos Hatzigiargyriou, Chairman ETP Smart Grids

Authors of use cases:

Authors	Company	Chapters	E-mail	Project
Georges Kariniotakis	Mines-Paritech	3.2	georges.kariniotakis@mines-paritech.fr	Anemos/Safewind
Rory Donnelly	3E	3.1.	rory.donnelly@3e.eu	SWIFT
Steven de Boeck	Energyville, KU Leuven	4.1.	steven.deboeck@energyville.be	iTesla
Anna-Carin Schneider	RWE	4.2.	annacarina.schneider@westnetz.de	GRID4EU
Anderskim Johansson	Vattenfall	4.3	anderskim.johansson@vattenfall.com	GRID4EU
Stephane Dotto	SAP	4.4.	stephane.dotto@sap.com	SAP view
Nikos Hatzigiargyriou	NTUA	4.5, 5.1., 6.2.	nh@power.ece.ntua.gr	NOBEL grid, SmarterEMC2, Smarthouse Smartgrid
Paul Hickey	ESB	4.6.	paul.hickey@esbnetworks.ie	Servo
Antonello Monti	RWTH Aachen	6.3, 6.4., 7.1.	amonti@eonerc.rwth-aachen.de	FINESCE, IDE4L, COOPERATE
Pieter Vingerhoets	Energyville KU Leuven	6.1.	pieter.vingerhoets@energyville.be	Linear
Nina Zalaznik, Sasha Bermann	Cybergrid	7.2., 7.3.	nina.Zalaznik@cyber-grid.com	eBadge, Flexiciency
Marcel Volkerts	USEF	7.4.	mvolkerts@usef.info	USEF

Speakers on the digitalization workshop: Rolf Riemenscheider (European Commission), Patrick Van Hove (European Commission), Antonello Monti (Aachen University), Joachim Teixeira (EDP), Alessio Montone (ENEL), Paul Hickey (ESB), Tom Raftery (Redmonk), Svend Wittern (SAP), Jean-Luc Dormoy (Energy Innovator).

ETP experts and reviewers: Venizelos Efthymiou, George Huitema, Fernando Garcia Martinez, Regine Belhomme, Miguel Gaspar, Joseph Houben, Marcelo Torres, Amador Gomez Lopez, Jonathan Leucci, Jochen Kreusel, Gundula Klesse, Ricardo Pastor, Artur Krukowski, Peter Hermans.

Special Thanks To: Patrick van Hove of the European Commission for his input, review and fruitful discussions, Marie Latour and Manuela Wunderlich of the ETP SmartGrids secretariat to organize the workshop.

Disclaimer: The opinions expressed in this document are the sole responsibility of the Smart Grids European Technology Platform and do not necessarily represent the official position of the European Commission.



This project has received funding from the European Union's Seventh Programme for research, technological development and demonstration under grant agreement No 308897.

Table of Contents

1) Foreword	04
2) What does Digital Transformation mean? What are the use cases ?	05
3) Practical use cases and field trials	07
3.1. Digital use cases for power generation	08
3.1.1 Probabilistic forecasting of wind generation, forecasting of extremes and optimal use of forecasts in power system operations and markets.	
3.1.2 Smart curtailment, dynamic line rating and Improved forecasting tools to maximize integration of wind	
3.2. Digital use cases for transmission & distribution networks	16
3.2.1 The STAR project: Remote operation and Grid Automation systems	
3.2.2 Innovative Tools for Electrical System Security within Large Areas	
3.2.3 Autonomous grid reconfiguration and forecasting in the MV grid	
3.2.4 Meter data management for network operation in the LV grid	
3.2.5 Collaborative Asset Management	
3.2.6 Advanced tools and ICT services for Distribution System Operators	
3.2.7 A Platform to interface demand side management with DSO needs	
3.3. Digital use cases for retailers and aggregators	38
3.3.1 Empowering SG Market Actors through Information and Communication Technologies	
3.3.2 IDE4L Use Cases on technical and commercial aggregators	
3.4. Digital use cases for consumers & Prosumers	45
3.4.1 Dynamic pricing and Demand Response Management	
3.4.2 Smart houses in a smart grid environment	
3.4.3 Smart charging of electric vehicles	
3.4.4 Neighborhood energy management	
3.4.5 Use cases	
3.4.6 Technology development needed to meet the challenges	
3.5. Digital use cases for new market platforms	56
3.5.1 Local Energy Markets	
3.5.2 ICT tools for cross-border markets	
3.5.3 The DSO as market facilitator	
3.5.4 The Universal Smart Energy Framework	
4) Main recommendations on Digital roadmap	64
Conclusions	67
Appendix: ETP SG Workshop on Energy Digitalization	68



1) Forward

The European Digital Single Market initiative will ensure that Europe's economy, industry and employment take advantage of digital technologies as a key driver for growth. All industrial sectors need to integrate these new technologies and manage the transition to a smart industrial society. Key initiatives include investment in ICT infrastructure such as cloud computing and Big Data, and ensuring that the massive amounts of data created by people or recorded mechanically bring added value that can be captured in Europe. Standardisation and "free flow of data" are also promoted to support these aims.

In addition to the industry transition, digitisation will have key implications for the way our societies manage health, food, water and energy. It is important to experiment with the digital age in these contexts and ensure that the digitisation helps shaping these areas to the advantage of European citizens.

In particular, digital technologies will bring key contributions to the achievement of the Energy Union objectives for the transition to a 21st century secure, affordable and climate-friendly energy. They will support a service-oriented energy system as customers expect a high-quality, personalised service available 24/7. As a first step, the current roll-out of smart meters and smart metering infrastructure in Europe will open up wide opportunities for connecting the smart homes, smart buildings and industry 4.0 with the energy grids.

The increasing amounts of variable renewable generation (e.g. wind, solar) will require controls with very fast reaction times and will need to be balanced with flexibility of generation, active demand, storage and interconnections. Their decentralised real-time monitoring will be made possible by a mix of physical and virtual data: accurate measurements from cheap sensors connected through the Internet of Things and complex forecasting based on Big Data and cloud computing.

The energy system infrastructure is based on large expensive technical assets with long life times. Sensor data and information will drive smart asset management and maintenance and allow optimised investments in operational and capital costs of the European energy infrastructure.

The smart management of energy systems based on Internet of Things data will also enable the development of optimised decentralised solutions based on a closer integration of various elements of the energy system, exploiting the combined capacities and flexibilities of electricity, gas, heating and cooling, and transport sectors.

Patrick van Hove,
European Commission

2) What does Digital Transformation mean? What are the use cases?

The challenges to operate the power system in a dynamic way all require an appropriate, reliable and secure communication system. Therefore, more and more players enter the market with expertise in other sectors like mobile telecom. However, outlining the required functionalities of the communication infrastructure, taking into account the rapidly changing electricity generation mix, the ageing power assets and changing market models is not a straightforward task.

In this report, we define ‘Digitalization of the energy system’ as ‘The process of implementing and operating a set of assets by monitoring, transferring and analysing data which have been generated by one of the actors in the energy system’.

This includes smart operation of the grid at all voltage levels to reduce losses and outage times, retailers that optimize their portfolio by balancing based on forecasting algorithms, aggregators that control flexible consumption for various business cases, and new market platforms that provide suitable interaction between all these actors to optimize the overall efficiency.

The Digitalization of Energy includes as well the Digital Multichannel interaction with the Customers, the transactions operated through Business Networks like buying and selling on electronic marketplaces and the digital management of information collected and operated by the workforce.

In this report, we present several of these use cases illustrated by practical examples in the field. In every use case, a digital aspect is

present that facilitates transition to a new way of energy system operation, either for Generators, Transmission or Distribution Network Operators, Retailers, Aggregators or Consumers.

The table below describes important use cases and their benefits for the different actors. Note that it is not the intention of this report to provide an exhaustive overview of all possible use cases that use digitalization. We list and describe some promising use cases through projects in Europe, based on which we can build a vision on the future power system. Most of the use cases described in this project are still in the innovation stage, which is in line with the ETP mission to discuss the future technologies and applications. In the last chapter, the top 10 recommendations are given to various stakeholders.

Table 1: Description and benefits of digital use cases

GENERAL USES	DESCRIPTION	PRACTICAL USE CASES IN THIS REPORT	EXPECTED BENEFITS
Forecasting generation	Improved forecasting tools can allow a more efficient operation of the grid, in combination with curtailment, reactive power injection and dynamic line rating	The SWIFT project, discussing a practical case where forecasting, dynamic line rating, curtailment and reactive power injection allow connection of a wind farm without a costly grid upgrade	Increase reliability of supply Increase renewable energy penetration Increase reliability of supply, reduce cost of Operations and Capex and improve quality of service
Network planning and operations	Improved digital options for digital network planning. Smart operation of the network using IT & OT integration, Big Data and Predictive Services (a large Dutch DSO collects 1.5 billion Grid sensor measurements to forecast the required operations in real time). Transmission & Distribution Networks and Power Generators' Assets new models: Smart products, Data-driven business models, Technology-driven customer engagement and New alliances.	The STAR grid project: Grid management at LV and MV level The iTesla project, Electrical system security within large areas The GRID4EU German demonstrator, autonomous grid reconfiguration and forecasting in the MV grid The GRID4eu Swedish demonstrator: Meter data management for network operation in the LV grid Collaborative asset management, the SAP view NOBEL GRID: Advanced tools and ICT services for DSO's The Servo Platform: interphase demand side management with DSO needs	Increase reliability of supply, reduce cost of Operations and Capex and improve quality of service Reduce CAPEX investments Improve quality of service Provide real time Asset Cockpits reducing incidents and outages Defer grid upgrades Enable flexible demand Increase renewable energy penetration
Digital use cases for Retailers and aggregators	The data that market facilitator provides (e.g. DSO) can be offered to other commercial parties to facilitate market operation	The Smarter EMC2 project: Empowering market actors through ICT technologies. IDE4L: digital tools for the technical and the commercial aggregator	Integrate flexible demand in the market Take grid constraints into account in market operation
Customer participation in the market	Full Customer Energy Management using Big Data and IOT. Smart devices to understand customer behavior by Utilities. Storage assets and EV's can become a part of the solution to integrate DER	The Linear project, dynamic pricing and residential demand response SmartHouse/Smartgrid FINESCE: Smart charging of electric vehicles COOPERATE: Neighborhood energy management	Peak shifting and portfolio optimization Integrate flexible demand Defer grid upgrades and peak shifting Reduce losses and ensure safe grid operation
Balancing	Digital tools allow the TSO to balance the network more efficiently	IOT big data collection from end customers and data aggregation balancing	Better matching of demand and supply across the energy mix
Integration of EV and storage	Storage assets and EV's can become a part of the solution to integrate DER (estimated total world energy storage market by the year 2020 is 50 billion \$)	Decentralised operation using DER EV coordination schemes	Increase reliability of supply Decreasing grid upgrade costs Avoid over-voltages Peak shaving for the consumer
Enable flexibility by leveraging electronic market places	The data that market facilitator provides (e.g. DSO) can be offered to other commercial parties to facilitate market operation.	FINESCE Local Energy markets eBadge: ICT tools for cross-border markets Use cases defined by the "Flexiciency" H2020 project The Universal Smart Energy framework	Enable flexibility to support the local grid Improved international market model New roles of the DSO as a market facilitator Developing an adequate market model for stakeholder interactions

3) Practical use cases and field trials

In this chapter, an overview of practical use cases is given per stakeholder. The objective of this chapter is not to present an exhaustive list of use cases, rather than providing practical information on actual field trials and projects, to build a vision on how digital technologies are changing the energy landscape.

Table 2: Overview of the discussed use cases

STAKEHOLDER	PRACTICAL USE CASE	PROJECT/FIELD TRIAL
(3.1) Power Generator	(3.1.1) Probabilistic forecasting of wind generation, extremes and optimal use in the system	Anemos/Safewind
	(3.1.2) Smart curtailment, dynamic line rating and Improved forecasting tools to maximize integration of wind	SWIFT
(3.2) Transmission & Distribution Networks	(3.2.1) Innovative Tools for Electrical System Security within Large Area	iTesla
	(3.2.2) Autonomous grid reconfiguration and forecasting in the MV grid	FP7 GRID4EU
	(3.2.3) Meter data management for network operation in the LV grid	FP7 GRID4EU
	(3.2.4) Collaborative Asset Management	SAP Asset Intelligence Network
	(3.2.5) Advanced tools and ICT services for Distribution System Operators	NOBEL GRID
	(3.2.6) A Platform to interface demand side management with DSO needs	SERVO
(3.3) Retailers and Aggregators	(3.3.1) Empowering SG Market Actors through Information and Communication Technologies	SmarterEMC2
	(3.3.2) IDE4L Use Cases on technical and commercial aggregators	IDE4L
(3.4) Consumers & Prosumers	(3.4.1) Dynamic pricing and Demand Response Management	Linear
	(3.4.2) Smart houses in a smart grid environment	SmartHouse/SmartGrid
	(3.4.3) Smart charging of electric vehicles	FINESCE
	(3.4.4) Neighborhood energy management	FP7 COOPERATE
(3.5) New Market Platforms	(3.5.1) Local Energy Markets	FINESCE
	(3.5.2) ICT tools for cross-border markets	eBadge
	(3.5.3) The DSO as market facilitator	FLEXICIENCY
	(3.5.4) The Universal Smart Energy Framework	USEF Foundation



3.1. Digital use cases for power generation

3.1.1 Probabilistic forecasting of wind generation, forecasting of extremes and optimal use of forecasts in power system operations and markets.

Overview of the ANEMOS, ANEMOS.plus and SafeWind projects

Integrating wind generation into power systems brings challenges because it depends on weather conditions. Forecasting the power output of wind farms, and the related uncertainties, is a means to facilitate large-scale integration of wind generation, in line with the EU goals for 20% of renewables by 2020.

Research in wind power forecasting in Europe dates back to the mid-80's, when the first publications on statistical approaches appeared. In the 90s the first "hybrid" forecasting systems were applied at end-users mainly in Denmark. It was only in 2002 when efforts were federated at EU level to work jointly on improving wind power predictability. Leading research organizations in the field together with pioneer industrial partners formed a consortium that developed the ANEMOS project (2002-2006), supported in part by the EC under the 5th Framework Programme. This project brought together competencies from different disciplines and developed a systematic work that permitted to advance significantly the state of the art in the field:

- The wind forecasting technology was mapped through an extensive state of the art report [1]. The first benchmarking exercise was organized where 11 European forecasting systems were evaluated using a standardised evaluation protocol.

- A number of statistical and high-resolution physical methods were developed. A new approach based on the combination of forecasting models and Numerical Weather Predictions (NWP) was proposed outperforming each individual model. This approach later became main stream in operational systems. Also, the first probabilistic approaches were proposed with formal ways to evaluate uncertainty in the forecasts.
- To provide a common framework to operate and evaluate different models, the ANEMOS forecast platform was developed and integrated multiple models in a standardised way. This platform was evaluated in real conditions at demonstrations at several end-users. After the end of the project it was industrialised and is used today by end-users like the Australian TSO and market operator AEMO.

Following ANEMOS, two main types of research gaps were identified:

- The first concerned the integration of forecasts and the associated uncertainty in the decision making processes of the end users.
- The second concerned the need to improve wind power predictability at "challenging" or "extreme" conditions, when most of the forecast error appears with an impact to end-users.

As a result, two follow-up European projects were developed: ANEMOS.plus (2008-2011) and SafeWind (2008-2012), funded in part by the EC under the 6th and 7th Framework Programmes

respectively. Together with ANEMOS, the three projects had a very focused goal: improving wind power forecasts and the associated value from their use. To achieve this objective, it was necessary to bring together experts with specific competences, such as meteorologists, forecasters, statisticians, engineers and others. Each project had as much as 23 partners from 9 countries. The projects were coordinated by ARMINES/MINES ParisTech.

The ANEMOS.plus project aimed at the development and demonstration of probabilistic approaches for the optimal management of electricity grids integrating large-shares of wind power generation. Traditionally, system operators manage the power system based on forecasts of the electricity demand which is highly predictable (typical errors are less than 4%). For this reason, power system management tools (i.e. unit commitment, economic dispatch a.o.) are in general based on deterministic approaches and thus not appropriate when high amount of intermittent resources are considered in the process.

In ANEMOS.plus project, at a first stage, the wind forecasting tools were enhanced with new functionalities such as probabilistic forecasting. At a second stage new probabilistic operational tools for managing wind generation and for trading in an electricity market have been developed. The project then focused on demonstrations identified as key challenges for large-scale integration of wind power into the electricity supply including:

1. Allocation of balancing power and definition of reserves for TSOs with demo cases in

Portugal (REN) and in UK/Northern Ireland (SONI);

2. Optimal scheduling of power systems with high wind penetration with demos in Ireland (EIRGRID and SONI) and in the island of Crete (PPC);
3. Congestion management in large power systems as well as local grids with demo in Germany (EWE);
4. Trading of wind power in electricity markets using advanced bidding strategies with demos in Denmark and Germany (Dong Energy and EWE) and finally
5. Management of storage associated to wind farms with test cases in Portugal and Spain.

The project has shown that the probabilistic approach brings several gains. As it provides “hedging” to a broader range of scenarios of wind generation than the deterministic approach, it enhances the security of the power systems without increasing the costs of operation. The adoption though of fully probabilistic tools in the daily practice is challenging and far from straightforward. It requires the development of a stochastic optimization paradigm, which is technically challenging and implies a change of operator’s attitudes and practices. In general it can be said that there is a mismatch between advances in research and their adoption by the industry. In the case of trading in electricity markets the use of probabilistic forecasts permitted to avoid 15% of imbalance costs compared to the current practice.

Prior to SafeWind project, the focus was on forecasting “usual” operating conditions.

However, challenging or extreme situations can result in severe forecasting errors that can be costly for both infrastructures (i.e. damage of wind turbines) and the electricity grid (i.e. black-out). SafeWind emerged to satisfy end-users’ need for specific approaches that substantially improve wind power predictability by reducing large errors, or by predicting extremes at local scale through to European scale. In addition, wind predictability was considered as a system design parameter linked to the investment phase, where the aim is to take optimal decisions when installing new wind farms.

SafeWind developed forecasting approaches for time scales ranging from few minutes ahead to some days ahead, and were considered single wind farms or aggregations at different geographical scales (region up to national). The resulting methods include:

- forecasting of large and severe variations of wind power (ramps);
- approaches for the generation of forecast scenarios taking into account the spatial and temporal correlations in the forecasts;
- new tools like prediction risk indices able to predict the level of error for the next day;
- methods to predict specific situations like cut-off of wind turbines that have a major impact in the production of a wind farm, etc.
- The project developed a “European vision” of wind power forecasting by establishing a database of 2000 meteorological stations throughout Europe that permitted to assess the weather situation over Europe. This was combined with data from around 150 wind farms. Exploiting this “big data” potential, spatiotemporal models were developed for

short term wind power forecasting that were found to outperform classical approaches by up to 20%. Also innovative tools for alarming and warning end-users on forthcoming situations involving large forecast errors were proposed.

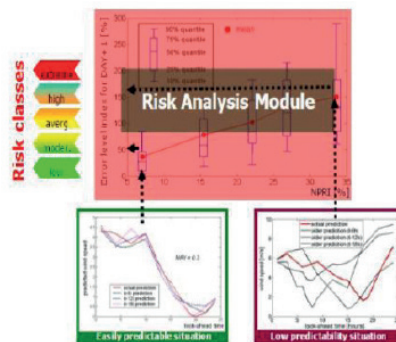
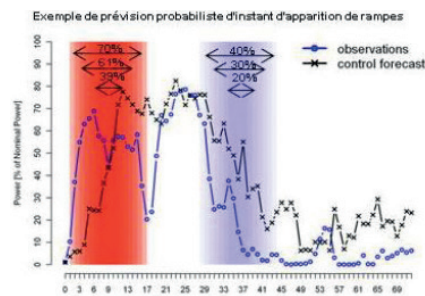
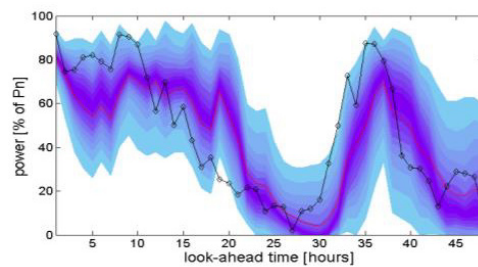

Figure 1: Example of a probabilistic forecast for a wind farm. Ramps forecasting based in ensemble NWP, Illustration of the prediction risk index concept based on ensembles.

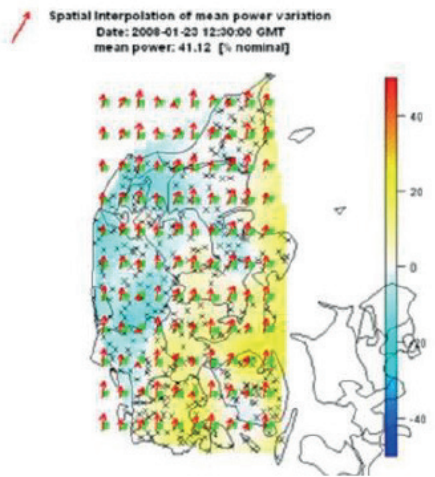
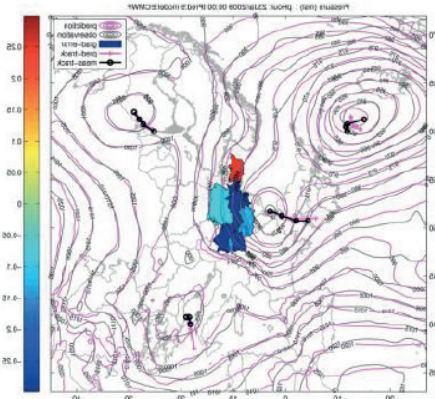
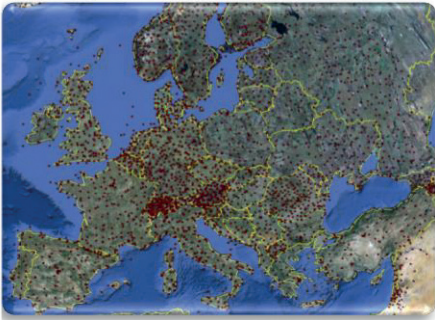



Figure 2: Network of 2000 weather stations considered in SafeWind. Analysis of weather patterns to detect large errors and model their propagation in space, Illustration of the spatiotemporal forecasting for the case of Denmark.

The role of the industrial partners was crucial since they provided among others real-world data that were used for the validation of the developed models. Recognising the role of meteorology when integrating renewables into power systems, a strategic collaboration was developed with the European Centre for Medium Range Weather Forecasts (ECMWF), the central research and operational weather forecasting centre in Europe. This permitted for first time to have research activities in the meteorology sector oriented to the renewable energy industry needs.

The SafeWind project developed Academic excellence and there were more than 150 scientific contributions to conferences and journals from which more than 44 were the papers to A rang peer-reviewed journals. In total, the three projects during the period 2002-2012 permitted significant advances in the state of the art with a total of more than 250 contributions at scientific conferences and journals imposing a European leadership in the field.

These experiences in wind forecasting acted as an accelerator for research in solar power forecasting, which in fewer years came at similar levels. The RES forecasting technology has reached a satisfactory level of maturity today. Operational systems are used in several countries and by different actors (TSOs, DSOs, producers, traders, a.o.). On-going research activities range from medium to high TRLs. There is a number of national or EU projects, mainly demonstration ones, that integrate renewable energy forecasting activities, but given that the topic is not the main focus in these projects, the impact in terms of improving predictability is in general smaller than that of dedicated projects.



Improving accuracy remains though a requirement by end-users. Lots of projects are carried out today aiming at developing “flexibility” technologies like active demand or storage that permit to handle uncertainties in RES generation. The large scale deployment of flexibilities sources involves high investment costs. One should consider in parallel how to reduce uncertainties and forecasts errors. This can be done by further multidisciplinary research in meteorology and renewable energy forecasting, by going “back to the basics”, that is, by carrying out more fundamental research at low TRLs (2-3) to permit breakthroughs.

-
- [1] “The State of the Art in Short-Term Prediction of Wind Power, A Literature Overview, 2nd Edition, http://www.safewind.eu/images/Articles/Deliverables/swind_deliverable_dp-1.4_sota_v1.1.pdf
 - [2] <http://www.anemos-plus.eu>
 - [3] <http://www.safewind.eu>

3.1.2 Smart curtailment, dynamic line rating and Improved forecasting tools to maximize integration of wind

OVERVIEW OF THE SWIFT PROJECT

Given current trends in renewable energy technologies, the realization of Europe’s ambitious renewable energy targets are expected to rely heavily on large wind farms. However, grid operators face substantial challenges to integrate these new production units: The requirement for substantial investments to extend the capacity of the network to accommodate the new production capacity at distribution grid level can result in the postponement of developments. Such projects can sometimes be approved before such upgrades are completed under strict curtailment rules resulting in the loss of substantial amounts of energy, impacting significantly the business case of the project and often leading to their cancellation.

The long-term objective of the Flemish innovation agency IWT funded project Smart Wind Farm conTrol (SWiFT), was to show how to maximize windfarm integration in distribution grids while minimizing the amount of lost wind energy at the lowest possible overall cost. This has been shown in an integrated case study in the Port of Antwerp through the application of real-time Active Network Monitoring and Control (ANMC) comprising innovative forecasting, dynamic line rating, and demand side management methods. Lead partner was the DSO Eandis, with contributions from iMinds, GE, 3E, DistriNet, EELab and IBCN.

Through the successful application of these methods, SWiFT has achieved a substantial breakthrough for smart grids; laying a baseline for how distribution grids can be designed in the future. The results of this project show that

a smart and flexible operation of assets allows the reduction of grid component dimensions and costs with no impact on safety margins and security of supply.

ROLE OF FORECASTING IN THE PROJECT

The monitoring and control system involves real-time control of production and consumption with the goal to optimize the use of the grid infrastructure. The system is built on (i) maximum exploitation of time-varying grid constraints through real-time line rating (RLR), (ii) advanced wind power production forecasting, and (iii) demand-side management (DSM) optimization algorithms using both Real-time Line Rating and wind forecast as inputs.

The wind power forecasting yields an estimate of the variable power injected in the distribution grid. This allows prediction of when the transformer connecting the distribution grid to the transmission grid will be overloaded, i.e. when local wind turbine generator (WTG) production will be very high. This then allows scheduling of variable loads within the local grid based on this prediction. In the case that sufficient loads cannot be scheduled, curtailment is minimized by means of Real-time Line Rating. Very short term forecasts are used, in combination with the RLR system, to ensure that curtailment is confirmed at the latest responsible moment, ensuring that the minimum curtailment possible is realized.

Various methods for very-short term forecasting were tested within the project and combined with a numerical weather prediction (NWP) model based approach. The prediction was also further developed using the real-time data from the wind turbine generators. Both methods allow calculation of the prediction intervals of the forecast. These confidence values are critical in allowing users to make

informed decisions based on the forecast, e.g. for inclusion in bidding strategies and market interaction, as described below.

SUMMARY OF MAIN RESULTS OF THE PROJECT

Improvements to both numerical weather prediction based (short term) and statistically based (very short term) approaches were tested. Historical production data made available within the research project allowed the development of automated data cleaning algorithms and the inclusion of these data into the definition of measured power curves. The NWP-based forecasts were significantly improved by this modification compared to the use of Manufacturer Power curves in combination with wake models. Additionally, the availability of real-time data access allowed the use of advanced statistical methods for very-short term predictions.

The optimal combination of these two approaches resulted in significant improvements over the baseline system, as shown in Figure 3. The resulting improvement in forecast accuracy is 1.8% in terms of park-level normalized mean absolute error (NMAE) over the entire 48h horizon. This improvement allows more certainty for implementation of DSM techniques such as industrial load shifting, which must be planned at least 1 day in advance.

Flexible operation of assets allows the reduction of grid component dimensions with no impact on safety margins or security of supply.

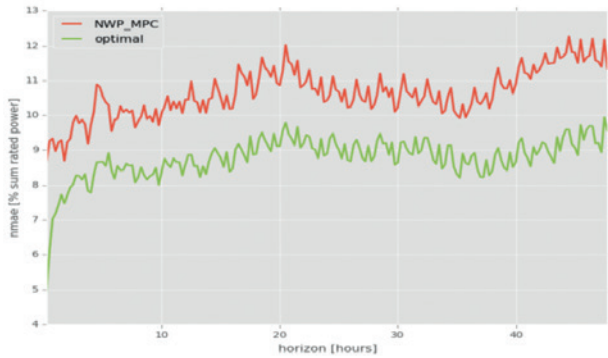

Figure 3: Normalised mean average error over 48 hour forecast horizon.

Over the very-short term (2 hours ahead), an optimal combination of very-short term algorithms and the NWP forecast resulted in a further 1.5% reduction in NMAE, allowing forecasts with NMAE lower than that of simple persistence, which remains today the benchmark over such short timeframes.

The improved forecast accuracy reduces the safety margin used by grid operators when preventing network congestion, meaning less curtailment is required to ensure grid stability and safety. With the development of a real-time system to incorporate the inclusion of these data for determination of curtailment requirements at the latest responsible moment, the improvements over the very-short term are of particular importance.

One of the key challenges for day-ahead forecasting of wind energy remains unscheduled outages. Either from planned maintenance or curtailment that is not communicated to the forecaster or unplanned maintenance or stop due to alarms, these outages can have large effects on the forecasts for small systems. Thankfully, the impact is then small on the overall grid. This should be considered if a

penalty system is adopted to enforce accurate predictions.

BENEFITS AND CHALLENGES OF DIGITALIZATION

With the development of the smart-grid in Europe and the trend towards distributed generation, storage and flexibility, these technologies will become increasingly required to supply ancillary services for grid stability at an acceptable cost.

3E is currently involved in a research project (FutureFlow [1]) targeting the development of a cross-border automatic frequency response reserve (aFRR) market allowing full participation by renewable energy aggregators (both solar and wind). One of the key aspects here is the determination of a market structure that will allow aggregators to contribute not only with downward reserve (power reduction), but also with upward reserve (power increase).

Market possibilities to realize this include reservation payments for under-production, or frequency support activation prices attractive enough to warrant the necessary economic risk by aggregators. Additionally, as described by Kreutzkamp et al. 2013 [2], intra-day forecasts which show increased production at the 97.5% confidence limit (required to deliver the same reliability as conventional plants) compared to day-ahead predictions allow this ‘newly available’ generation to be bid on a frequency support market, as shown in Figure 2.

The curtailment system is also useful to not disconnect when a fault is occurring at higher voltages in the grid.

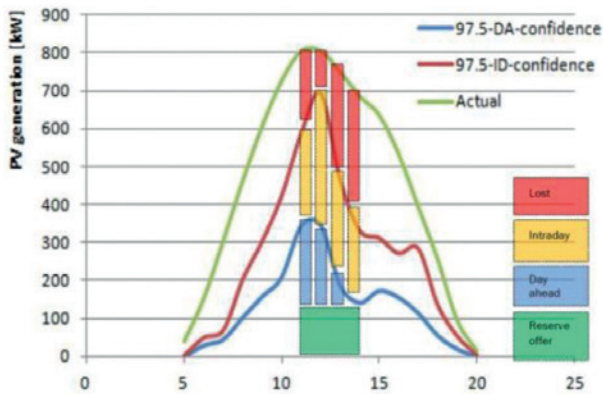

Figure 4: Updated intra-day forecasts can be used to allocate production to different markets.

Along with these market restructures, the shift of ancillary services from a limited number of fossil power plants to a vast amount of distributed generators with flexible reserve offerings will require grid operators to further develop their procurement strategies for these new reserves to guarantee grid stability at an acceptable cost, i.e. adapting requirements to offer support during all moments over a day which exclude renewable energy sources.

The challenge in the coming years will be to further reduce forecast uncertainties at all time horizons and further automate decision systems built upon these forecasts (flexibility activation approvals, curtailment requirements etc.) to reduce the lead time for such decisions and allow the ‘lost energy’ shown in Figure 4 to be minimised.

- [1] FutureFlow Project H2020 GA 691777
- [2] Kreutzkamp, Paul, Omar Gammoh, Karel De Brabandere, and Manoël Rekingier, “PV Forecasting Confidence Intervals for Reserve Planning and System Operation: Results of the IEE REserviceS project,” presented at the EU PVSEC 2013, Paris, 2013.



3.2. Digital use cases for power generation

3.2.1 The STAR project: Remote operation and Grid Automation systems

STAR (“Sistemas de Telegestión y Automatización de Red” - Remote Operation and Grid Automation Systems) is the name of a deployment Smart Grid project led by IBERDROLA which is integrating Smart Grid technologies and research results. As a matter of fact STAR has become the fundamental base for the digitalization of the Networks Business in Iberdrola Group.

From the very beginning STAR coupled the Smart Meter (SM) deployment with the integration of new supervision and control systems at MV as well as at LV. Abundant equipment and systems developed at R&D projects have been included in the field deployment and operation procedures. Now they are the business as usual:

- Automatic Grid Recovery system solves automatically eventual faults in the grid, in 100.000 km of MV lines, not only using the feeder affected but also using other feeders and substations to correct the problem without human participation. A centralized approach has been the bases for a quick deployment after development in GRID4EU (demo-3). Initially using the existing remotely controllable infrastructure, now using also FD.
- The modification of settings for the Fault Detectors (FD) is nowadays made automatic and remotely, using web-services which are manufacturer-independent.
- The concentrators used for SM data collection at secondary substation (SS) level include now the functionality to detect

through LV measurements open circuits at one phase of the MV lines which frequently, normal protection systems cannot detect (GRID4EU demo-3).

- LV real-time supervision systems are reporting information about secondary substations including LV feeders.
- Tools for fraud detection compare the information from Data Concentrators at SS level with the SM measurements collected by the MDM system to search for SS with high probability of non-technical losses.
- Since 2016, 2nd of July, it is compulsory for Distribution companies at Spain to have 100% of hourly consumption curves from all SM to provide retailers with complete information for billing establishing the appropriate base for future demand response services. Consumers have also access to this information to make optimization decisions.

At the beginning of 2016, 7 million of Smart Meters are already installed from a total of 10.5 million. More than 6 million of them are effectively integrated in the high end systems (MDC, MDM), showing an average unavailability of 0.09 which is equivalent to 9 days for 1% of SM in operation. The capabilities of this solution include the remote update of SM firmware (2.2 million of SM were remotely updated in 2015 to incorporate new functionalities).

Most of people associate SM to measurements for billing but they are providing other important added value. They provide also low voltage grid information like unbalances at transformers and LV lines level, information about the voltage

at transformers and consumer premises, certain customer's events like phase or neutral opened, and information under request about overvoltage duration, for example.

All this new information is producing a change in the operation methods and the qualification required for certain works. A new dispatching centre is being developed for LV grids at UPGRID project to take advantage of the information provided for this infrastructure. IGREENGrid project analysed, among other supervision solutions the capabilities of SM to provide voltage real-time measurements for areas with high DRES penetration, and STAR is taking advantage of these capabilities of PRIME. These kinds of projects are providing the bases to support a different way of operating low voltage grids.

Telecommunication is also a crucial element, enabler of all these Smart Grid technologies that is always evolving quickly. Research projects have also provided abundant improvements in this field, such as PRIME technology originated long ago in a European research collaborative project called OPERA, today implemented at STAR deployment, but currently, research continues producing results:

- A “high availability” solution for a critical element which is the MV broadband power line (MV-BPL) to link secondary substations among them using utility infrastructure. Master-slave systems have a weak point in the master element. Now, certain slave-elements have the capability to detect a failure in the Master and to assume its role re-establishing the telecommunications.
- A field study about the “guard distance” on the MV BPL has allowed reducing the security distances among telecommunication cells using the same frequency, to half

previous values. This is increasing the possibilities while guarantying the absence of disturbances among cells.

- A compact solution for “data concentrator” integrating telecommunications was developed as R&D and now is used for SS that present a low concentration of customers
- New and more performant PLC coupling systems

The deployment of so large Smart Grid project has required new management tools, specific for STAR, to control the progress of work, the incidences, the status of the different systems, the pending tasks and to deal with the new information available for all stakeholders, inside and outside the company.

3.2.2 Innovative Tools for Electrical System Security within Large Areas

The iTesla project aims at improving network operations with a new security assessment tool able to cope with increasingly uncertain operating conditions and take advantage of the growing flexibility of the grid.

Framework and goals:

Pan-European transmission system security issues will become more and more challenging due to:

- the growing contribution of renewable energy sources
- the introduction of new controllable devices
- a partially controllable electricity demand; the increasing difficulty to build new overhead transmission lines
- and the progressive construction of a single European electricity market.

This will result in more complex system operation, a grid working closer to its operational limits and therefore a need for a major revision of operational rules and procedures. Coordinated operation initiatives have already emerged for different regions of the pan-European transmission system (CORESO, TSC), but they require a new generation of tools allowing the different TSOs to increase coordination.

The developed toolbox supports the decision making process for network operation from two-days ahead to real time, based on these main features:

- provide a risk-based assessment taking into account and modelling the different sources of uncertainties (in particular intermittent power generation), the probabilities of contingencies and the possible failures of corrective actions.

- perform accurate security assessment taking into account the dynamics of the system using time-domain simulations.
- provide operators with relevant proposals of preventive and corrective actions to keep the system in a secure state.
- handle a continuous multi-period optimization problem from 2 days ahead to real time under uncertainty.

The toolbox allows TSOs to address network simulations of their own system, of coordinated regional systems or of the whole Pan-European system.

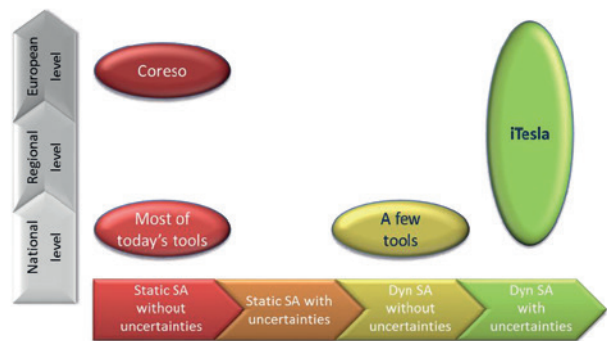

Figure 5: Position of iTesla platform and tools compared to state of the art

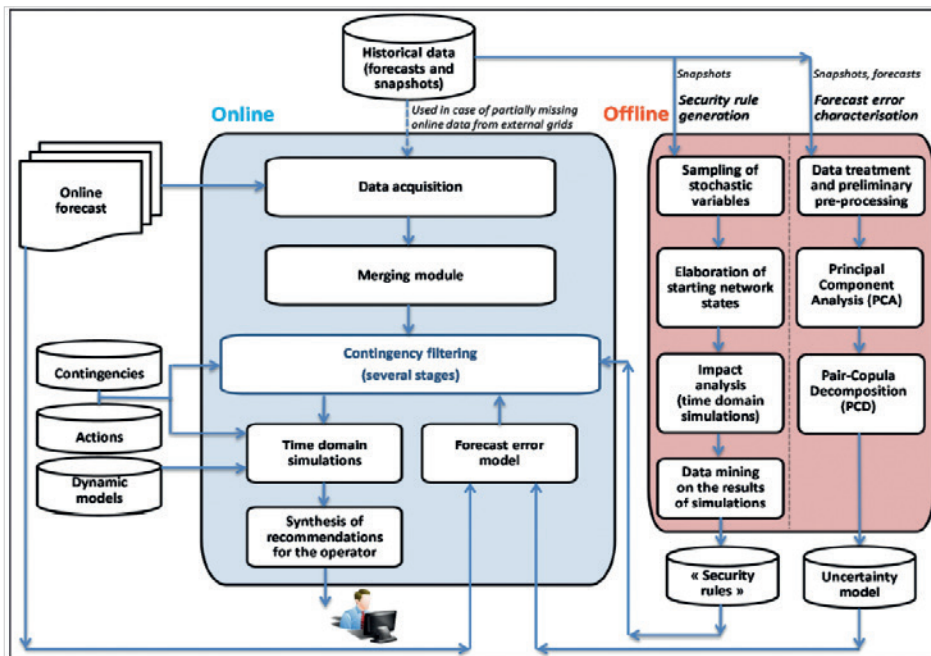

Figure 6: Overall work flow of the iTESLA platform

THE ITESLA PLATFORM AND MODULES:

The overall work flow of the iTESLA platform is given in the figure above.

The iTesla platform consists of two major parts, namely the offline and online analysis. The offline toolbox generates the generation rules and forecasts the error characteristics based on historical data. This analysis is performed once every week as it requires more computational capacity. The online analysis is a continuously running analysis that performs the security analysis from D-2 up to real time based on snapshots, online forecast of the system state and the results of the offline analysis. As such this analysis is not the same as a real time analysis. The online analysis differs from the currently used online analysis on three aspects: contingency filtering, uncertainty model and time domain simulations. The contingency filtering comprises several filter stages, such

as the worst state approach, Monte Carlo-like approach and corrective control optimization, to minimize the computational burden. The goal of the security rules in the contingency filtering is to provide a security judgement for the post-contingency outcome based on the pre-contingency system quantities without performing any power flow or time domain simulations. After the contingency filtering based on the security rules, the remaining set is analysed in detail with dynamic simulations. As such a dynamic model for all network components is needed. Therefore also a dynamic models library has been composed and validated inside the iTesla project. Finally a synthesis of these simulations is made and control actions are recommended to the operator.

The construction of the offline security rules is performed by applying data mining methods on the results of a large set of time domain



simulated contingencies, taking static and dynamic constraints into account. The input for the time domain simulations is generated by sampling all stochastic variables for all possible starting states of the network. The data mining is performed by applying the decision tree and K-nearest neighbour algorithms.

The uncertainty model is composed based on historical data by using the principal component analysis and pair-copula decomposition.

Finally the toolbox has been validated on several national and regional use cases, including different type of stability phenomena.

Defence plans and restoration

A different part of the iTesla project focused on the last line of defence, when the system enters the alert or emergency state, and the automatic restoration scheme composition. The work on defence plans first identified the weak points in the current implemented defence plans. Subsequently more detailed studies have been done to identify the role of renewable generation plants (focus on wind), Pan-European coordination, PMUs and out of step relays and distributed energy sources in defence plans.

The work on renewable generation plants concluded that:

- Wind farms can contribute during over frequency situations
- Increasing the volume of secondary reserves contributes in reducing the risk of temporary imbalances caused by wind power uncertainties
- Wind power can reduce the time required for power system restoration.

The work on Pan-European coordination of controllable device concluded that:

- Coordinated control can contribute significantly in managing alert and emergency situations in the power system, specifically overloads and inter-area oscillations
- Tools for automatic control actions with power flow controlling devices are recommended as support for operators and backup for failed control actions.

The work on PMU and out of step relay tuning showed that:

- A tool for automatic tuning of out of step relay parameters is developed and implemented on a realistic power system.
- The use of PMUs in out of step relays is promising.

The work on distributed energy sources in under frequency load shedding schemes showed that:

- The robustness of current UFLS schemes comes under pressure from the increased penetration of distributed generation
- Different feeder ranking methods have been designed and successfully implemented on real power system data of different DSOs. The scheme robustness can be improved while reducing consumer impact. Therefore it recommended to take distributed generation into account for the feeder ranking in UFLS scheme design.

3.2.3 Autonomous grid reconfiguration and forecasting in the MV grid

The German Demonstrator in the GRID4EU project (www.grid4eu.com) addressed the challenge of integrating more distributed energy sources in the grid with the demonstrator built up in the area of “Reken”, located in North Rhine-Westphalia. In this demonstration, monitoring and control are implemented for a smart operation of the grid. The considered grid was well selected since it showed already at the beginning of the project a balance between installed generation power and maximum demand. Further increase in renewables to be connected was forecast. The grid focused on consists of 85 secondary substations.

The following objectives are targeted:

- Integrating an increasing number of Renewable Energy Sources (RES) in the medium-voltage (MV) network and underlying low-voltage (LV) networks
- Achieving higher reliability, shorter recovery times after grid failures
- Avoiding unknown overloads and voltage violations
- Fulfilling the needs of surveillance and remote-control in MV networks
- Reducing network losses

The principle idea is to implement an Autonomous Switching System (ASS) that is based on an autonomous interaction between de-centrally installed modules in selected secondary substations and a lean control centre in the primary substation. All decentralized modules provide measured values and, furthermore, some of them are equipped with remote controlled switching gear. The central module collects all needed data and generates switching programs

derived from the current state of the grid. The possibility of autonomous switching provides dynamic topology reconfiguration which is a new concept of operation.

Specification sheet

DEMO1  RWE	
Location	Reken, North Rhine-Westphalia, Germany
Demographic density	Semi-urban
Project scope	<ul style="list-style-type: none"> • 1 HV/MV primary substation • 3 MV lines for a total of 145 km • 85 MV/LV secondary substations (18 are “smart-equipped”) • 14,400 LV customers
Climate	Moderate (continental)
Specific conditions	<ul style="list-style-type: none"> • High share of distributed generation, mainly wind and photovoltaic • Local balance between installed generation power and peak demand • Further increase in renewables to be connected is forecast
Project partners	<ul style="list-style-type: none"> • RWE • Westnetz • ABB • TU Dortmund
Use Cases tested	<ul style="list-style-type: none"> • Failure management in MV networks • Decentralized grid operation in MV networks • Reduction of grid losses

AUTONOMOUS MODULES

The Autonomous Switching System is based on an autonomous interaction between modules implemented in secondary substations and a control centre located in the primary substation.

The modules are divided into two groups:

- Measuring modules that provide field measurements,
- Switching modules which perform field measurements and execute the switch gear.

The control centre and all modules are equipped with a Remote Terminal Unit (RTU). The interaction between the three components is illustrated in the Figure 7

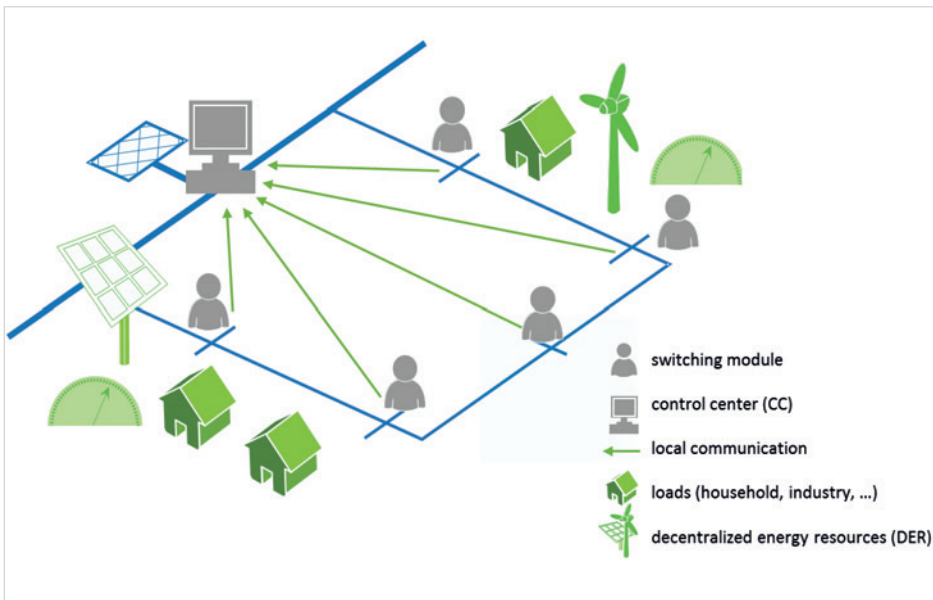

Figure 7: The basic principle

For safety reasons, the modules have to be equipped with a service-modus (deactivation of autonomous switching and remote-control) for work on the grid (e.g. maintenance). If service or maintenance works are in progress, earthed parts of the grid have to stay earthed and modules are not allowed to switch.

To get more information about the implementation of the modules on the field, please refer to the “Autonomous modules” and “Autonomous Switching System infrastructure” spotlights of the GRID4EU German demonstrator.

THE COMMUNICATION INFRASTRUCTURE

For all information exchanges, the protocol IEC 60870-5-104 is used, whether it is within the Autonomous Switching System or with the SCADA. This exchange of data is not limited to the measured information, like status of a switch or the voltage, also all information about the status of the modules is transferred by using this protocol.

Concerning the communication structure, the necessary ICT infrastructure has been set up to ensure the communication between:

- The central RTU in the Control Centre and the grid control system (SCADA).
- The central RTU and the decentralised RTUs in the switching and measuring modules.

The secondary substations (modules) send data via a GPRS connection to an APN . The information is then forwarded to the central RTU through the backbone of the process data network. Finally, the central RTU collects all the data and provides it to the control system (SCADA).



All these information exchanges are performed thanks to a hierarchic network based on the following communication structure:

- A basic level, the TCP/IP data flow, going through the VPN-router located at the communication centre.
- A second layer, the encrypted VPN. As a central approach was chosen (communication towards one single “Master module”, the RTU in the primary substation), it is always established from the master RTU towards the VPN-router.
- A third level, the dedicated “modules-network”. As soon as the master RTU is connected to the VPN, logical IEC 60870-5-104 connections can be established between the modules and the master module, as well as with the SCADA system. This is always initiated by the master or SCADA (controlling substation).

The RTU information, like indications, goes through all these levels.

To get more information about the communication infrastructure, please refer to the “communication infrastructure” spotlights of the GRID4EU German team.

The IT solutions are usually adapted to the needs in the new Smart Grid domain and are often vendor specific. A lot of work needs to be done to combine the different domains network, IT and SCADA into a working system.

THE GRID RESTORATION ALGORITHM

After a fault occurred in the MV grid (e.g. short circuit) the circuit breaker at the primary substation switches off the entire bay so that every secondary substation in the feeder suffers an outage. Thus, the objective of the restoration algorithm is to identify the faulty grid section, to isolate the most compact part of the grid and to recover the energy supply in the remaining grid. This procedure is often defined by the term FDIR - fault detection, isolation and restoration.

Four tasks are involved in the overall procedure. First, the short circuit (SC) detections put the system in the post-fault state. SC indications provide a data basis for finding the affected network section between monitored secondary substations. Then, an algorithm for finding the minimal switchable section of the network computes the switching programme which would isolate this part of the network. The isolation phase is carried out by the execution task. In the following step a restoration scheme has to be computed. This new topology enables repowering the previously switched-off parts of the network, which are by now isolated from the faulty section. The final step is carried out by the execution task.

To get more information about the restoration algorithm, please refer to the dD1.4 Deliverable document of the GRID4EU German team.



SWITCHING PROGRAM MANAGEMENT ALGORITHM

The switching program management is a supporting routine which is required for performing switching actions in all use cases: decentralized grid operation, fault management and loss reduction. A switching program describes a sequence of switching actions and some additional information:

- Activation time
- Initial topology
- Switches to close
- Switches to open

The activation time is use case dependent and can express an immediate execution or a scheduled switching action. In order to guarantee a consistent topology reconfiguration the assumed initial topology state is attached. If the topology has been changed (e.g. by manual operation) before the execution of the switching program, the execution of the programme has to be cancelled.

All switching programs are stored in a queue object and are managed by the switching program management task.

To get more information about the switching program management algorithm, please refer to the dD1.3 Deliverable document of the GRID4EU German team.

THE GRID RECONFIGURATION ALGORITHM

The developed Autonomous Switching System uses a grid reconfiguration algorithm in different cases:

- Decentralized medium voltage network operation: as a reaction to congestions or overvoltages in the grid
- Failure management: as an algorithm for finding a new network topology when restoring the grid

- Loss reduction: for finding a loss-optimal network topology for a certain period of time, predicted by a forecast-based algorithm

Due to its nature the reconfiguration algorithm is implemented centrally on the master RTU unit. Data from all secondary substations is collected and used as input. Secondary substation RTUs are also responsible for the execution of switching commands.

The algorithm flow is depicted in Figure 8, based on the “Decentralized medium voltage network operation” Use case, considering an occurred congestion. The triggering event is a decentrally detected state violation (voltage or current), which is forwarded to the master RTU.

Necessary input data for this functionality, the present [P, Q] snapshot and the online topology are continuously forwarded to the master unit. In the next step the static reconfiguration algorithm is applied. A target topology is calculated and the switching program management task schedules a switching action sequence for immediate execution.

When the reconfiguration execution is completed, a secure state is supposed to be reached. This concept cannot be directly compared with the closed control loop principle. Though, a feedback of the behaviour of the system is given indirectly by the state machine mechanism.

As input data, current active and reactive power measurements and online switch states are used. A load flow based algorithm determines an optimal topology which eliminates voltage or current limit violations. A switching program is prepared for immediate execution. After the reconfiguration the overall system state is being optimized.



Figure 8: Congestion Management Algorithm



Figure 9: Forecast based loss reduction algorithm

To get more information about the grid reconfiguration algorithm, please refer to the “grid reconfiguration algorithm” spotlight of the GRID4EU German Demonstrator.

THE FORECAST ALGORITHM

For the loss reducing grid operation knowledge of middle-term grid behaviour is required. In order to provide this information, active and reactive power flow forecasts are computed locally at the secondary substation level. Every 15 minutes forecast data is forwarded to the central RTU at the primary substation and used as input for the loss reduction algorithm.

Especially with regard to the limited hardware capabilities of the RTUs a double seasonal exponential smoothing forecast technique is used. This does not require any additional information (e.g. weather data) and uses only measurements and their 15 minutes average values as input data for the forecast.

To get more information about the grid forecast algorithm, please refer to the “forecasting algorithms” spotlights of the GRID4EU German demonstrator.

THE FORECAST BASED LOSS REDUCTION ALGORITHM

On the one hand, every significant network state change should be followed by a reconfiguration process for gaining maximal loss-reducing

effect. On the other hand, a high number of switching actions results in faster wear of the switching devices.

A trade-off for less switching actions and still good loss reducing operation is to be found. In order to find this balance a network state forecast is carried out. The network state might be represented by the residual load, which consists of the sum of the active nodal power measurements acquired at the secondary substation level.

The proposed loss reduction algorithm is applied periodically (every 15 minutes) and consists of the following structure (see the Figure 9).

After the local power forecasts have been collected, they are mapped onto a reduced network model which is required for load flow computations. Based on local forecasts the residual load is calculated. This variable provides possible times for switching actions. To obtain target topologies for these times average forecasted active and reactive power values for the supposed time interval are calculated. When switching time and target topology are obtained, the corresponding switching action is scheduled for possible future execution. Every 15 minutes the scheduled actions are checked by applying more precise data from the updated forecast. When the scheduled time is reached the switching action has to be executed.

To get more information about the forecast based loss reduction algorithm, please refer to the “forecasting algorithms” spotlights of the GRID4EU German demonstrator.

IMPACT ON SUPPLY RELIABILITY

Simulations of different events of fault indicated that a higher level of automation leads to an improved security of supply. The calculated values for SAIDI and ASIDI are available in the following table:

Situation	SAIDI in min/a	SAIDI in min/a
Current state	12.8	14.9
System applied	6.1	7.5

Table 3: Losses reduction over one year simulation

On average, the Autonomous Switching System reduces the time of reconfiguration by 21,5%.

IMPACT ON GRID LOSSES

The testing results in MATLAB showed that the mean absolute percentage error varies between <1% and 12%. With this forecast precision, it is possible to reduce significantly the number of switching actions when compared with the optimal reference:

	Network losses	Switching actions*
Static topology	100%	0
Optimal reconfig.	71.3%	17814
Forecast-based	79.7%	3142

Table 4: * One switching action = switch on/off

To get more information about these algorithms, the German demonstrator and the entire GRID4EU project, download the final report via the website www.grid4eu.eu

3.2.4 Meter data management for network operation in the LV grid

The LV network that VATTENFALL Distribution operates in Sweden is to a large extent considered as rural / semi-rural. Indeed about 83% of the secondary substations and approximately 57% of the Swedish customers supplied by Vattenfall are classified as part of the LV rural/semi-rural network. Moreover the number of customers per secondary substation in these parts of the network is relatively low with an average of 14.4.



The Swedish GRID4EU demonstrator aims at testing a solution for improved outage and power quality

management of the LV network. The implemented solution allows the monitoring of the LV network by deploying intelligent equipment in secondary substations (RTUs) and using the existing Smart Meters that have been deployed at all customers' premises several years ago.

Apart from addressing the objective mentioned in the previous paragraph, Swedish Demonstrator also analyzed the possibility of using only the power quality events provided by the AMM system to monitor the LV network. Although such analysis would not be as beneficial as the combined analysis of meter and RTU data for monitoring the LV network, it would still be very valuable in cases in which there were no RTUs installed. Today most of all the secondary substations are not equipped with any advanced measuring devices.

Information from two different sources are used and combined in an integrated back office system environment. The solution supports different user needs and operating functions such as network planning, optimization, power quality analysis, field service processes etc.

SPECIFICATION SHEET

DEMO2  	
Location	Outside Uppsala, Sweden
Demographic density	Rural/Semi-rural area
Project scope	<ul style="list-style-type: none"> ▪ 100+ MV/LV secondary substations ▪ 600 LV lines for a total of approx 600 km ▪ 10,600 LV customers
Climate	Cold & stormy (continental, oceanic)
Specific conditions	<ul style="list-style-type: none"> ▪ AMM technology implemented at consumers' premises since years ▪ High level of market deregulation ▪ Both rural and urban complexities in the grid infrastructure
Project partners	<ul style="list-style-type: none"> ▪ Vattenfall ▪ ABB ▪ KTH ▪ Schneider Electric ▪ eMeter, a Siemens Business
Use Cases tested	<ul style="list-style-type: none"> ▪ Outage detection in LV networks

THE ADVANCED METERING INFRASTRUCTURE (AMI)

The Swedish Demonstrator has included some 10,600 Smart Meters connected to 100+ Data Concentrators. Together with the PLC communication infrastructure and integrations with the AMM collecting system, this forms the Smart Metering Infrastructure.

Data Concentrators (DC) are collecting metering data from the meters being installed on the same power line structure as the DC. The DC is in turn connected to the overlying collection system via GPRS. The data traffic uses common standards (OSGP) and passes the telecom operator communication platform and servers before being exported to the AMM Collecting system server through VPN integration.

The AMI system exports data to the MDMS:

- Smart Meter data
- Measurement values
- Events/alarms. The SCADA generates an alarm, which is instantly processed by the DMS to red mark the line in questions to indicate the loss of power. This improves the fault location time. Events are divided into general and real time events. General events are collected once a day and real time events are collected as soon as possible after occurrence. Real time events are defined to be of more importance for power quality monitoring and quality of supply to the customers.

The Swedish Demonstrator also analyzed the possibility of using only the power quality events provided by the AMM system to monitor the LV network. Although such analysis would not be as beneficial as the combined analysis of meter and RTU data for monitoring the LV network, it would still be very valuable in cases in which there were no RTUs installed. Today most of all the secondary

substations are not equipped with any advanced measuring devices.

THE MDMS

The MDMS platform provides a tool for in-depth analysis of customer and network behaviour. The high level functional configurations and integrations relevant to MDMS testing in order to run MDMS properly are:

- VPN environment
 - The demonstration application is installed as a “stand alone” solution, separated from the operating Vattenfall system environment.
- Asset Synchronization
 - Network assets and relationships was made in a one-time synch with Vattenfall Master systems and the MDMS. The same with DMS/RTU system data.
- Meter Read and Event processing
- Interfacing with the AMI system (measurement values and events/alarms) is done via VIP (Vattenfall Integration Platform).
 - Data from the DMS_RTU is processed using a file format point to point connection.

The reporting framework Analytics Foundation is designed to pull data out of the MDMS and create a purpose built database.

From the wide range of reports, only Load Analysis and Device Event reports were used for the Swedish Demonstrator analysis.

Load analysis reports show load usage data, load curves and load duration curves. These reports provide a way to drill into load usage from a high-level view (secondary substation).

Device Event reports are used to track outage issues, trends and impacts. These reports provide

a way to drill down into events from a high level view to individual customers or single delivery points (SDP). Events are sorted into predetermined buckets for easier analysis. For instance, the following Device Event summary table shows that 192 SDPs experienced an outage at that time:

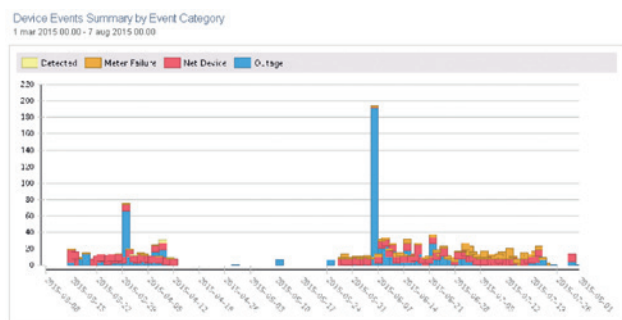

Figure 10: Device event summary table

Figure 10: Device event summary table

Partners of the Swedish Demonstrator agreed on the most interesting events coming from the smart metering system from power quality point of view and that would be useful for monitoring the LV network. Those events and their definitions are listed below:

- Events generated at smart meters
 - Reverse Energy. The meter has registered reverse power. Typically occurs if the consumer is generating power, otherwise the meter may be mis-wired. Could also be considered as a possible tamper event.
 - Sag. This event occurs when a voltage sag is detected in any phase. The voltage must drop below 10% of the rated voltage (230 V) to be recorded as an event.
 - Surge. This event occurs when a voltage surge is detected in any phase. The voltage must be above 10% of the rated voltage to be recorded as an event.

- Phase Loss. Voltage below 61% of the rated voltage has occurred on at least one phase.
- Power Outage. Power outage occurred at the meter. Expected when power outages occur. The event will be reported after power is restored.
- Events generated at data concentrators
 - Phase Inversion. This event occurs when the meter experiences phase inversion. This alarm may occur because the meter is mis-wired, although in some cases it can occur simply due to noise on the power line.
- Events generated in AMM Platform Titanium, as an algorithm
 - Zero Fault. A zero fault event is triggered when there is a surge above 270 V and also a sag event.
 - Extremely High Voltage. This event is triggered when there is a surge above 270 V and no sag event.
 - High Voltage Fuse Broken. This event is triggered when two phases are below 30% of the nominal value and one phase is within 10% up or down the nominal value.

RTUS

RTUs are deployed at secondary substation and are connected to each outgoing LV line.

All three phases are measured. RTU's are communicating with built in GPRS modem, using IEC 60870-5-104 protocol.

The use of a RTU solution in secondary substations allows the detection of outages and LV faults through the following process:

- The RTU detects an outage or a LV fault, e.g. a drop in current on one or more phase, and reports a warning to the SCADA system. This improves the fault awareness time.
- The SCADA generates an alarm, which is instantly processed by the DMS to red mark the line in questions to indicate the loss of power. This improves the fault location time.
- The isolation work is done manually by the operator who uses information mainly from the RTU to work more efficiently. This information will help to reduce the isolation time in field.

The system environment, the location to host the system hardware, was selected based on primarily IT and Information security regulations. The hardware is located outside Vattenfall ordinary network, on a test net operated by Vattenfall R&D department. "Open" network connections between the Vattenfall corporate network and the Swedish Demonstrator environment was not allowed to be established. Data was also needed to be anonymous.

The future LV monitoring solution will contain a combination of different technical solutions, from only using smart meters to advanced equipment in secondary substations.

THE DISTRIBUTION MANAGEMENT SYSTEM

The Distribution management system (DMS600) in the Swedish Demonstrator comprises two functionalities. Both target operator awareness and in aim to shorten lead time in fault location and fault resolution times (SAIDI);

- AMR Meter Event visualization
 - A functionality which processes selected high priority events from the meters at customer premises and maps them to the

right meter in the DMS. The DMS has a complete representation of all customer meters on the feeders monitored within the demo. This functionality allows an operator to quickly spot where a specific customer event is located.

- Current or voltage drop visualization
 - As a way to signal a drop in current on a feeder or voltage drop in the busbar in the LV network. ABB has implemented a functionality that mimics the behaviour of the DMS in case of a breaker opening. When the SCADA gets a signal that a line drops to near zero current, the fictive breaker is set as open and the line in question is marked red to indicate the loss of power.

The combination of these two functions gives an operator swift indication when a fault occurs. This enables quick action to be taken, either to monitor that power is restored or to initiate an investigation.

THE SYS600 HISTORIAN

The SYS600 Historian is a historical database. It is dynamically updated and presents live data along with historical data to give graphs of measured values. The operators choose content. Through discussions with Vattenfall operations staff, ABB has created graphs that help operator monitor, live or historically, the consumption, power quality and technical losses.

The historian has access to data on energy supplied on each outgoing feeder in any substation. At the same time, the system receives meter data on consumed energy from the individual meters connected to the feeders. Historian then produces a graph where supplied energy, consumed energy and the diff on a selected feeder or substation is shown. By setting this up per station, it is easy to identify troublesome stations and on those set up

monitoring for the individual feeders to further pinpoint the source of the technical loss.

THE COMMUNICATION INFRASTRUCTURE

The system was implemented in the Vattenfall R&D location Älvkarleby and is connected to a test net, entirely separated from the ordinary Vattenfall corporate network.

Within the system, there are three kind of communication:

- Smart Meters use PLC communication with the Data Concentrator
- Data Concentrator communicates with built in GPRS modem, using OSGP protocol
- RTUs communicate with built in GPRS modem, using IEC 60870-5-104 protocol.

3.2.5 Collaborative Asset Management

An efficient and smart grid needs to rely on a robust asset infrastructure. The performance of the assets directly impacts the grid operation and the smart grid is moving to the digital world. This requires to move to an ecosystem where every consumer and every machine is connected, disrupting all the established rules around business channels. Connectivity, networking and technology infrastructure drive the movement of goods, services, people and knowledge.

Utility industry is under pressure to meet the demands of consumers, regulation and the carbon economy, amidst the added challenges of containing costs and maintaining ageing assets. Maintenance costs significantly impact production volumes and related revenue stream. Assets need to remain operational for longer periods, where maintenance or shutdown overruns mean lower productivity.

The current processes and systems around maintenance are disconnected and not automated



within the asset management value chain. The various stakeholders have relied on the model of “request/receive” which is no longer efficient as asset systems are getting more and more complex. Large amounts of data need to be continuously exchanged with operators, OEMs (Original equipment manufacturers), service providers, etc.

KEY CHALLENGES

- Companies have to face to disconnected stakeholders who are working in silos: Design and master data, Maintenance data, Performance data, Inventory data, maintenance instructions, task lists, analytical data etc. are not connected and reduce operational efficiency
- There is no standardized/shared model information. No common definition, leading to inefficient and inconsistent collaboration
- There is no systematic and enterprise-wide collaboration on asset management processes with business partners
- Every manufacturer and operator is doing the same manual data work and it's always out of date
- The lack of complete and consumable asset information undermines smart decision making when buying and using equipment,

The transition to the digital economy and the increasing adoption of new technologies such as the Internet of Things (IoT) and cloud-based networks provide an opportunity to automate the data exchange and enable a simplified collaboration model among these stakeholders via asset management networks: cables, transformers, pylon, public light, solar panel, wind turbine, alternator, turbines, switchers, insulators, etc.

BUSINESS BENEFITS

There are number of factors driving the need of improved collaboration within the asset management ecosystem:

- Grid operators want to minimize capital investments, operational overheads, and risks
- Original equipment manufacturers (OEMs) want to drive revenue growth and competitive advantage with bundled products and services
- Service providers want to provide value-added services enabled by new technological innovations

There is significant value potential for operators from moving onto an Asset Intelligence Network:

- Reduce capital expenditure and maintenance costs
- Improve asset reliability and employee productivity
- Speed up and improve decision making with better asset data quality and transparency across manufacturers
- Reduce collaboration complexity with common metadata on the network

Business innovation is now moving at lightning speed. Technology infrastructure is now rented to eliminate barriers to entry. B2B transaction are moving to new cloud based collaboration platforms, where businesses, users, systems are connected. This is time to go for “Asset Facebook” that will allow to connect devices through a platform.

TECHNOLOGY DEVELOPMENT NEEDED TO MEET THE CHALLENGES

The transition to the digital economy and cloud-based Internet of Things provides an opportunity to automate and enable a simplified collaboration model among the stakeholders via asset management networks.

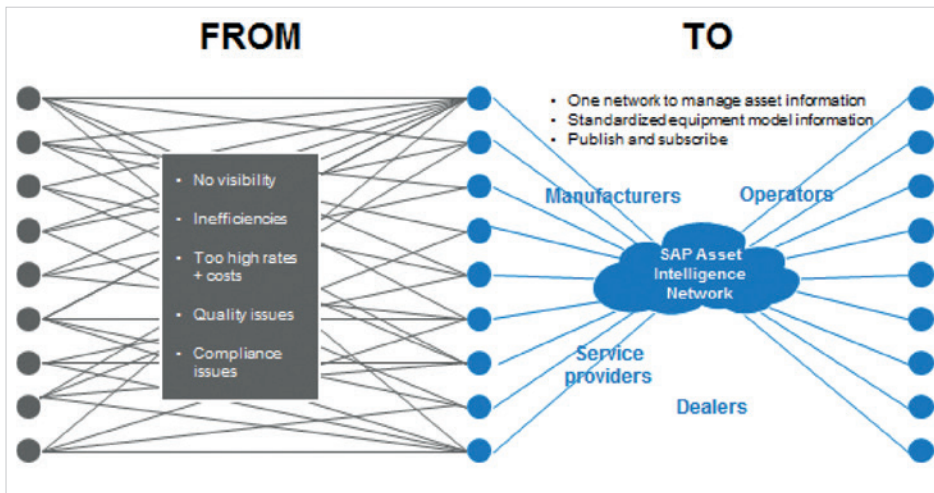

Figure 11: Towards a Cloud-based Internet of Things

The next wave of innovation can be facilitated by bringing the asset ecosystem partners onto a single cloud-based collaborative network platform. SAP has identified four key pillars to deliver an asset intelligence network that brings together multiple business partners on a common platform:

- Content: Single register of the worlds' assets, providing a unique identifying service and associated metadata within a global taxonomy to provide the foundation for asset management and customer service business processes
- Network: Asset operators, OEMs, EPCs, and service providers on a platform to collaborate, exchange information and best practices on asset deployment, maintenance instructions, asset performance feedback, advanced analytics, etc.
- Applications: Applications on the network platform for customers to collaborate on equipment management, maintenance execution processes, advanced analytics, etc.
- Integration: Out-of-the-box integration with various SAP solutions to facilitate seamless data exchange between enterprise and plant systems as well as the network

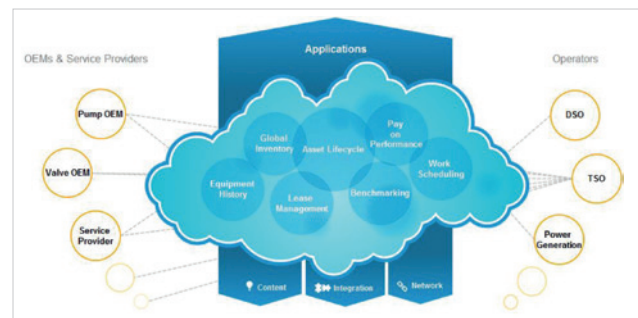

Figure 12: SAP Asset Intelligent Network

The need of collaboration between OEMs, operators and services providers is very important and can have multiple benefits across a range of areas. For instance, the SAP Asset Intelligence Network using a secure cloud platform is open to any OEM, operator and service provider. SAP has a neutral role in governing and safeguarding each participant’s confidentiality.

SAP innovations can be classified into three broad categories:

- **Standardized equipment management:** It will be possible for operators or their proxy, to create equipment instances in the SAP Asset Intelligence Network using the standardized model as a template. The unique equipment ID will facilitate matching of assets across operators , OEMs, and service providers
- **Maintenance process execution:** This will facilitate collaborative maintenance execution processes for the operators, such as business context for predictive maintenance, service bulletins, recalls and warranty, collaborative work execution, and results sharing
- **Collaborative network services** covers areas such as equipment as a service, results sharing, equipment performance analysis, etc.

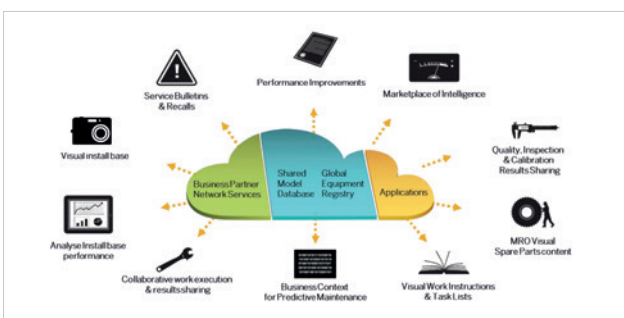

Figure 13: Collaborative Asset Management like a “Facebook of Assets”

An Asset Intelligence Network will be instrumental in supporting accuracy of asset information, one version of the truth, ease of collaboration on asset data, easy access to asset information, even when the process crosses organizational boundaries, and availability of asset information for other applications.

3.2.6 Advanced tools and ICT services for Distribution System Operators

NOBEL GRID will develop, deploy and evaluate advanced tools and ICT services for Distribution System Operators and electric cooperatives, enabling active consumers’ involvement -i.e. demand response schemas - and flexibility of the market - i.e. new business models for aggregators and ESCOs and integration of distributed renewable energy production. Through the dual-use of telecommunication networks, and by validating the integration of distributed renewable generation and demand response systems, NOBEL GRID will offer advanced services, not only for DSO’s but to all actors in the distribution grid and retail electricity market in order to ensure that EU citizens will benefit from better prices, more secure and stable grids and renewable electricity supply.

NOBEL GRID will cover three different types of Innovative Actions. The first one, and core of the project, will be the development and demonstration of innovative solutions and tools in order to improve medium and low voltage electricity distribution networks, providing secure, stable and robust smart grids allowing DSOs to mitigate costs of management, replacement and maintenance of the grid in presence of very large share of renewable energy. This will include intelligent active control of the network, of the active and reactive power flows, fault and outage management, automatic control concepts, network synchronization, active loads and

distributed storage integration. At the end, NOBEL GRID approach will provide to all customers better prices and the access to a low carbon electricity supply. The second action is the development, integration and real demonstration of new services to be provided to all the actors of the electricity distribution grid and market. This will include services for next generation distributed renewable energy integration and active demand response. Three different applications will be developed for the different actors:

1. Grid Management and Maintenance Master Framework for DSOs (G3M Framework): this a toolset will allow DSOs to control and manage the distribution network, including next generation distributed renewable energy integration, in order to keep operators aware of the smart grid problems in real time and reduce the costs in management, maintenance and security. Thus, the G3M framework will integrate seamlessly the outcome of the first action. The G3M framework will integrate seamlessly the outcome of the first action.
2. Energy Monitoring and Analysis App for domestic and industrial prosumers (EMA App): This application will provide to the end-users with a mobile and web tool to manage and monitor in real time the data concerning electricity consumption and production, such as billing, forecast, etc. The project will implement and test an interface to inform prosumers about their consumption habits and try to modify their behaviour by means of price incentives, for instance, promoted by aggregators, ESCOS and retailers - in this way the users will not participate as observing subjects but also will be invited to affect the grid stability and balancing by means of new business models. In this tool, the information will come from the prosumers smart metering infrastructure- integrating the results of the

third Innovative Action targeted by the project -, but also from other sources such as weather information, retailer tariffs and products, etc.

3. DR Flexible Market cockpit for aggregators, ESCOs and retailers (DRFM cockpit). This application will bridge Demand-Side Resources and their flexibility with the distribution grid actors to improve the operation of the processes under their control and more specifically to maximize profit and manage deviations' for Aggregators and Retailers, while supporting grid operators to ensure network stability and security. The tool will allow for the optimization of Aggregators', Retailers' and ESCOs' consumers portfolios performance and will facilitate demand response strategies optimization in technical/ operational and financial terms.

The third action includes the deployment and demonstration of innovative solutions to lower the cost of the development and deployment of smart metering systems. NOBEL GRID will address this action at three different levels:

1. Promoting and testing the concept of an Unbundled Smart Meter (USM), based on commercially existing smart meters, but enabling end-users to directly access its data and services. Thus, promoting the development of third party added value services that will lead to deployment cost reductions.
2. Developing and testing a new Smart Low-cost Advanced Meter (SLAM), which focus will not only be on providing the usual meter capabilities at lower costs - reducing component costs by removing for instance unnecessary displays - but also in addressing specifically the needs of the prosumers with regards to data analysis and services.

- 
3. Interfacing with Smart Home Environments and Building Management Systems (BMS) that could autonomously interpret and if necessary execute the DR commands coming from the DRFM cockpit.

All these three actions will be deployed and tested at large scale in five different sites in five EU members' states. NOBEL GRID has selected them to maximize the EU-wide impact, and prioritising the trials with cooperatives and non-profit partners. The main advantage of this is the high level of investment these parties keep on grid innovation with regards to other electric profit companies, which guarantees their commitment for the rapid adoption of technologies benefiting the society as a whole.

3.2.7 A Platform to interface demand side management with DSO needs

The aim of the 'Servo' platform is a service allowing DSM aggregators the greatest possible freedom to control load without compromising network performance and integrity. It will operate as a mechanism ensuring that 100% of network availability is exposed to customers and aggregators without incurring unavoidable increases in electrical network costs.

The main objectives of Servo are:

- Allow flexible users the greatest possible freedom to control load without:
 - Compromising electrical network performance and integrity
 - Increasing electrical network investment costs
- Introduce a standard model and interface through which DSM Aggregators/DSU's will be guided in the future to ensure optimal access to ESB's Networks

- Ensure DSM Aggregator systems conform to and interact with Servo in an efficient, globally adopted, secure fashion
- Introduce verifiable electrical state throughout the whole electricity value chain
- Set a precedent that DSM Aggregator switching requests will be contingent on ESN judgment as to whether network standards will be breached in the event of such switching
- Safeguard the electrical system from significant changes in load

BACKGROUND

ESBN make decisions on the need to reinforce network for voltage quality based on the worst case instance that is likely to occur. This is commonly based on the principles of diversity in energy consumption in residential segments of network. The active control of loads and generators at a DSO level can have substantial negative effects on the distribution system particularly at an LV level. Such effects/breaches of each utilities planning rules and of EN50160 standards, even if they occur over a very short period of time, cause significant problems to the DSO and customers.

Examples of this would be :

- Exceeded diversity
- Exceeding MIC
- Short voltage dips
- More extended low voltage
- High voltages
- Disruption of connection agreements

In addition to the immediate negative impacts on customers there is risk of damage and loss of revenue during the time that plant is out of service. This means that DSO's must currently plan for the worst case event that can credibly



occur, although this event may be infrequent on many networks.

Demand Side Management (DSM) and the connection of new technologies (eMobility, micro-generation, advanced storage heating) will potentially mean that the maximum or minimum loading and diversity assumptions made in the sizing of existing networks will be exceeded. Without careful management of these technologies in operation, would likely incur network planning and standards breaches and potentially individual DSM customers exceeding their individual connection agreement. In such scenarios facilitating these systems without voltage or loading standards being contravened requires some of the following:

1. A visual and analytics engine which can highlight potential problem areas effectively based on existing data
2. Significant network reinforcement at medium and low voltage in the short term and the uprate of 38 kV transformers and other high voltage plant in the medium and long term
3. A means of real time monitoring, analysis and control of MV and LV assets
4. A balanced combination of these strategies based on least cost or greatest return in a given situation.

If a third party can turn on/off a significant portion of load without obligation to request from DSO/TSO entities, ESNB have to plan for a worst case contingency. This implies all networks have to be built to accommodate all connected load and/or generation being fully on or off.

Planning for a worst case contingency in this manner (albeit extremely rare) will result in far higher network development costs. Considerable savings can be delivered if reliable systems could be put in place to facilitate DSM while precluding

excessive clustered simultaneous operation of loads beyond the capacity of existing or future network.

BENEFITS OF DIGITALIZATION

By monitoring information on utilisation of distribution segments which have DSM in place, it is possible to grant such switching if voltage/thermal standards do not become breached as a direct consequence. This allows for the full capacity of the distribution system to become utilized with DSM without any further restriction and with minimal need for investment. As relevant contingencies are rarely realised the impact on DSM operation would be minimal.

Servo is currently under development, it consists of a platform and set of standards which addresses the issues highlighted above. It comprises of policies, roles and also a number of software components aware of LV, MV, HV systems and all actors in the electrical system. Through the use of commonly understood, globally adopted protocols, Servo interacts with all actors using a single model. This drastically simplifies the ability to engage with parties based on an agnostic approach.

Benefits of the Servo include:

- The opportunity to increase overall distribution system utilization up to 100% and significantly reduce additional reinforcement costs
- Introduce a mechanism capable of autonomously appraising network conditions to give insight on network capability to support mass rollout of DSM
- Vision of areas of concern as DSM increases throughout the system, alleviating the need for mass rollout of sensors and intelligent devices in unconstrained areas

- The ability to monitor asset condition and lifecycle effecting expenditures associated with replacement and maintenance
- Defeating the need to proactively reinforce networks and adopt a reactive model towards roll out and replacement of assets

The intents of a DSO should not be to cross beyond the point of the customer meter and gain control of loads and generation within premises/ plants. This compromises and undermines the role of supplier, retailer, TSO and customer. The role of the DSO is to facilitate as is best possible all entities which interface and interact with its networks while ensuring that no external event negatively impacts network users. Direct control of load is not explicitly required to maintain control as a DSO. Servo uses commonly used protocols to interact with individuals, groups, communities and aggregators alike to ensure that the electrical system is fully exposed to all users to be completely utilized while also ensuring that it is safeguarded from actions which could adversely affect the distribution system's operations.

Direct control of loads is not explicitly required to maintain control as a DSO

3.3. Digital use cases for retailers and aggregators

3.3.1 Empowering SG Market Actors through Information and Communication Technologies

The SmarterEMC2 project focuses on the further analysis and development of technologies that will provide smart grid actors such as aggregators with new functionalities. Those functionalities will allow them to participate in the electricity markets as well as to contribute to the optimal operation of the distribution grid by providing ancillary services. The project is focused on the distribution domain and uses the SGAM framework to model and analyze use cases. A fully digitalized framework is proposed by the project consortium in order to implement a set of use cases that include, among others, Virtual Power Plants and Demand Response. Figure 14 presents the SmarterEMC2 High Level Conceptual Architecture, with all relevant components to be

developed: DRMS-Demand Response Management System, VPP Platform, LCMS-Local Constraint Management System and Energy Hub (micro-smart grid management). The Virtual Power Plant will be tested in a pilot site in Greece, while the Demand Response use case will be tested in two sites, in Greece and Turkey. Both use cases require a fully digitalized environment and will be described next. In addition, both use cases make use of data analytics applications such as forecasting, and produce a big amount of data that need to be quickly and efficiently accessed. The Data Analytics Platform is proposed to handle this task. The platform will store data and provide meaningful visualizations as well as execute data mining and data analytics tasks that will support the operation of pilot sites.

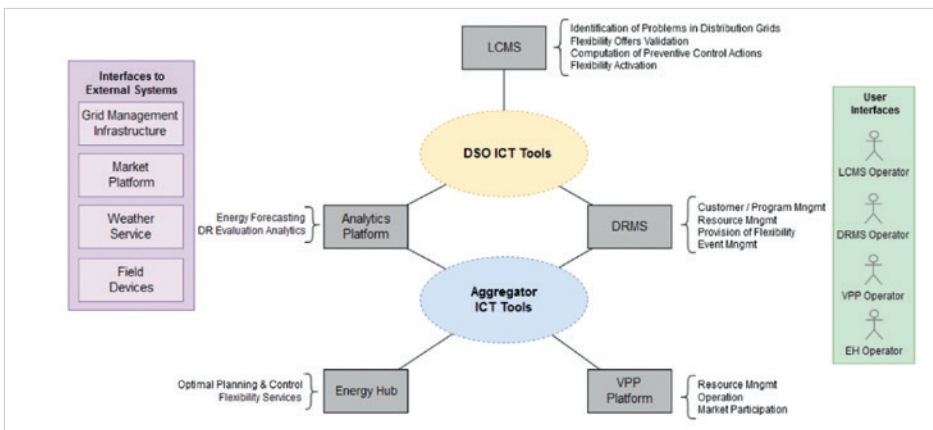



Figure 14: The SmarterEMC2 High Level Conceptual Architecture



Both use cases that will be presented next require a high level of digitalization. VPP and DR Aggregators may be responsible of a large number of assets producing a vast amount of information that needs to be accessed and organized in the most efficient manner in order for optimal operation to be achieved. At the same time, the aggregators will require access to external digital resources from various domains, like market data, data related to the distribution network operation, weather and other environmental data. This will enable aggregators to optimally dispatch their units, either loads, DGs or storage systems. In addition, digitalization will enable aggregators to easily design new services and allocate the most suitable programs (for example Real Time Pricing) to their customers.

A. VIRTUAL POWER PLANTS

DER installation sizes typically start from a few kW, while large RES installation sizes are in the scale of MW. Thus, it is difficult for DER to compete with other generation units in a liberalized energy market. In addition, the ‘fit-and-forget’ attitude towards distributed generation made it difficult to be accessed by system operators and thus it was impossible for DERs to provide ancillary services to the grid. Virtual Power Plants (VPPs) are proposed in order to face these issues. VPPs integrate any number of DGs of any type that are not necessarily physically connected, meaning that they may be installed in completely different geographical locations. In addition, VPPs may also include loads (controllable or not) or storage systems, indicating that the structure of a VPP varies according to its assets. Summing up, a VPP can be considered as a distribution system level aggregator.

I. Market participation

The first set of use cases addressed by the project is market participation, and more specifically wholesale and intraday market participation. In

this use case the VPP concept is used in order to achieve active customer participation, by allowing the participation of DER and active loads in the market. The VPP is assumed to aggregate various types of DERs, both controllable (μ CHPs, Diesel Generators, etc) and not-controllable (PVs, Wind Turbines etc), as well as storage (batteries, fuel cells etc) and flexible loads. Various VPPs are assumed to co-exist in the same market environment. The VPP Operator first requires forecasted values for energy consumption/production and for market prices. Using this information together with the VPP asset’s flexibility information it is possible to calculate the optimal bid to be placed in the wholesale market. After market closure the VPP Operator receives a day-ahead schedule to be implemented. After receiving the schedule the VPP Operator needs to schedule its operation and next optimally dispatch its units in real time. The dispatch takes place either by sending incentive signals to the participants or by exploiting specific flexibility contracts signed between DG Owners and the VPP Owner. It is possible though, because of the stochastic nature of consumption and RES production, for the VPP Operator (and other market players) not to be able to implement their contracted day-ahead energy output. To resolve this problem the intraday market initiates its operation right after the closure of the wholesale market. Actors place bids on excess and lack of energy. The VPP Operator computes the optimal intraday market bid and places it on the market platform. The market operator computes the new schedules and sends them back to the market participants. The VPP Operator optimally dispatches this new schedule.

The Virtual Power Plant concept should be used to achieve customer participation, by allowing DER and flexible loads in the market.



II. Voltage Support

The Virtual Power Plant in this case is considered to provide ancillary services to the distribution grid, and more specifically voltage support. A Virtual Power Plant might include units in different parts of the distribution grid and thus only the local operation of a VPP is considered here. This means that the VPP is considered to include various types of units (DERs, Loads and Storage) connected on the same bus or different buses of the same distribution grid. These units are considered to participate in the wholesale and day ahead market with the Virtual Power Plant, but in case voltage violations are detected the VPP must be able to participate in voltage support together with other Distribution Grid components (other VPPs, DR Aggregators, independent DERs and Storage Systems, OLTC, AVR's etc). All components will have to provide their flexibilities to the DMS responsible for calculating the optimal dispatch in a centralized manner in order to solve the voltage problems. The DMS will then send optimal operation points to the Virtual Power Plant Operator. The Virtual Power Plant Operator, will then have to dispatch its units (if dispatch is in fact possible) in an optimal way. Dispatch is possible in the case where a number of VPP assets (DER/Load Owners) are connected on the same bus (for example group of buildings that include loads, DERs and storage system).

B. DEMAND RESPONSE

The central actor of the Demand Response use case is the DR Aggregator. This actor aggregates and manages resources in order to provide ancillary services to the DSO or participate in the energy market. In the “Demand Response Dispatch for Grid Operations” use case demand response is used for the efficient and secure grid operation, presenting a case where the DSO has access to the DRMS platform. In the “Demand Response Dispatch for Market Participation” the processes related to

flexibility aggregation and market participation through flexibility offerings, presenting the perspective of the DR Aggregator are described. Finally, the management processes of DR assets like registration of resources, critical information exchange, measurement & verification of DR events are presented in the “Demand Response Resource Management” use case.

I. Demand Response Dispatch for Grid Operations

The Distribution System Operator (DSO) is responsible for the reliable and efficient operation of the distribution grid (DG). An alternative solution for solving congestion problems in the DG, to the ordinary solution of field equipment control actions, is managing flexible loads. Harvesting the flexibility provided by Smart Consumers or DR Aggregators, the DSO can manage the network more efficiently and postpone costly network upgrades. This flexibility can be provided either through bilateral agreements (DR contracts) or through offerings in a dedicated energy market. Flexibility can be deployed in day-ahead planning, for mid-term management, or in intraday planning for short-term management of the grid. The latter requires short response times, not greater than 15min.

II. Demand Response Dispatch for Market Participation

The DR Aggregator has a pool of contracts with Smart Consumers and the ability to participate in the energy markets to offer its available flexibility (production and consumption capacity). The aggregation of flexibility of individual resources requires, apart from assessing the status of the DR resources and estimating the relevant cost of the flexibility, taking into account other factors such as: grid constraints set by the DSO, planned DR events and projected weather conditions. Taking into account all heterogeneous factors, the aggregator, calculates and places a bid in the energy market. If the price offer is validated

and below market price, then the DR Aggregator receives a schedule of production/consumption and proceeds with the delivery of this flexibility in an optimized manner.

III. Demand Response Resource Management

A Demand Response Management System (DRMS) manages the communication and information processes of different types of resources e.g. smart loads, DERs as well as with other similar systems. The DRMS has automated processes for handling registration / de-registration of resources and the synchronization of critical information (telemetry data, availability schedule for DR events) which shall operate in a consistent and secure manner. Furthermore, the system manages the measurement and verification process in order to provide input to settlement entities.

3.3.2 IDE4L Use Cases on technical and commercial aggregators

The aggregator covers the role of aggregation of flexibility and energy both on demand and offer sides. The one from demand side is called “technical aggregator” and is usually implemented in the DSO’s control center, whereas the “commercial aggregator” represents the offer for flexibility. Figure 15 shows how the DSO will include a new functionality called “technical aggregator” and the retailer, that currently purchase energy, may evolve to commercial aggregator role, including also the possibility to purchase flexibility.

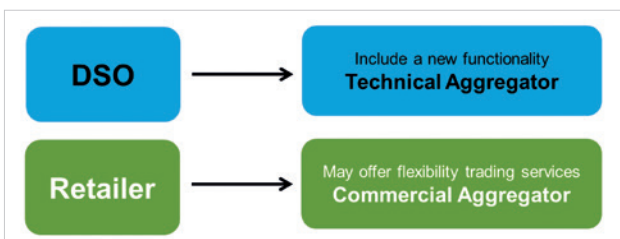

Figure 15: New concept for retailers and DSOs developed in IDE4L project

The product that may be sold by commercial aggregators and bought by commercial aggregators goes under the following classification.

Scheduled Re-Profiling (SRP): Obligation for a specified demand modification (increase or decrease) at a given time. It is in a few words an amount of energy.

Conditional Re-Profiling (CRP): Capacity for a specified demand modification (increase or decrease) at a given time. The modification is activated by a control signal from the buyer. It is a flexibility product.

TECHNICAL AGGREGATOR

The DSO in the control center analyzes continuously the current and forecasted data in order to identify voltages out of security limits, congestions or imbalances. In this case he can purchase flexibility in the market in order to avoid such occurrences. The technical aggregator splits the power injection requests onto several bids and trades them in the market. The main functionalities of the technical aggregator are the following:

- Load Areas (LAs). The buses are grouped in Load Areas (LA) and the Macro Load Areas (MLA). The MLA are allocated by TSOs (therefore the DSOs will operate in one or more MLAs), whereas the DSO-technical aggregator allocates the LA. The definition of the load areas is done in such a way that the consumers are grouped in terms of, consumption pattern, impedance value and type of connectivity of consumers; so that the consumers of each LA present a similar impact on the network operating constraints. The definition of LAs should avoid determining LAs that are too small and generating too many LAs and define LAs that are observable, in the sense that enough measurements are available at the boundaries of the LA to determine its operating status. Figure 16 shows an example of MLAs and LAs allocation.

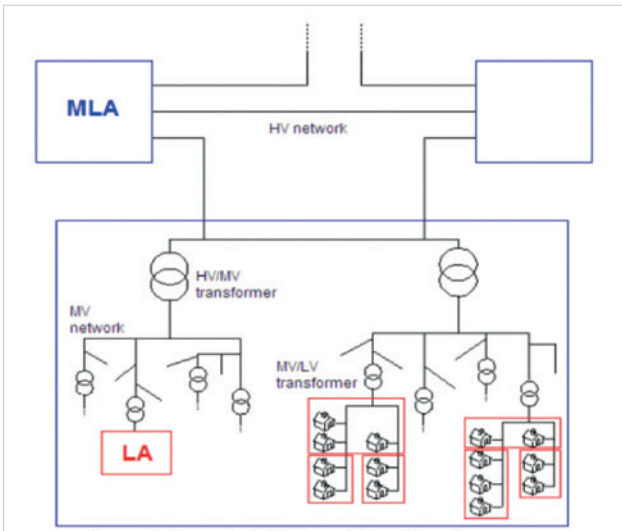

Figure 16: Example of MLAs and LAs allocation

- Off-Line Validation (OLV). The OLV is used for the Day-Ahead and Intra-day Market Validation of SRP and CRP products. It is done in a way that the DSO-technical aggregator realizes if the market clearing output brings any limit violation in the network. If this is the case a curtailment factor is applied. The DSO performs an Optimal Power Flow in order to find the minimum amount of DR that should be curtailed. The same process is applied by TSOs on MLAs, after they have received the plan of the LAs. The final decision on curtailments, is sent to Commercial Aggregators. This process is applied right after the day-ahead market gate closure. The validation algorithm is run for timeslots of 15 minutes. This means that the validation is not executed for the whole day-ahead period, but for every 15 min. time slot independently. The OLV diagram is presented in Figure 17.
- Real-Time Validation (RTV). The Real-Time Validation (RTV) tool is used by DSO before

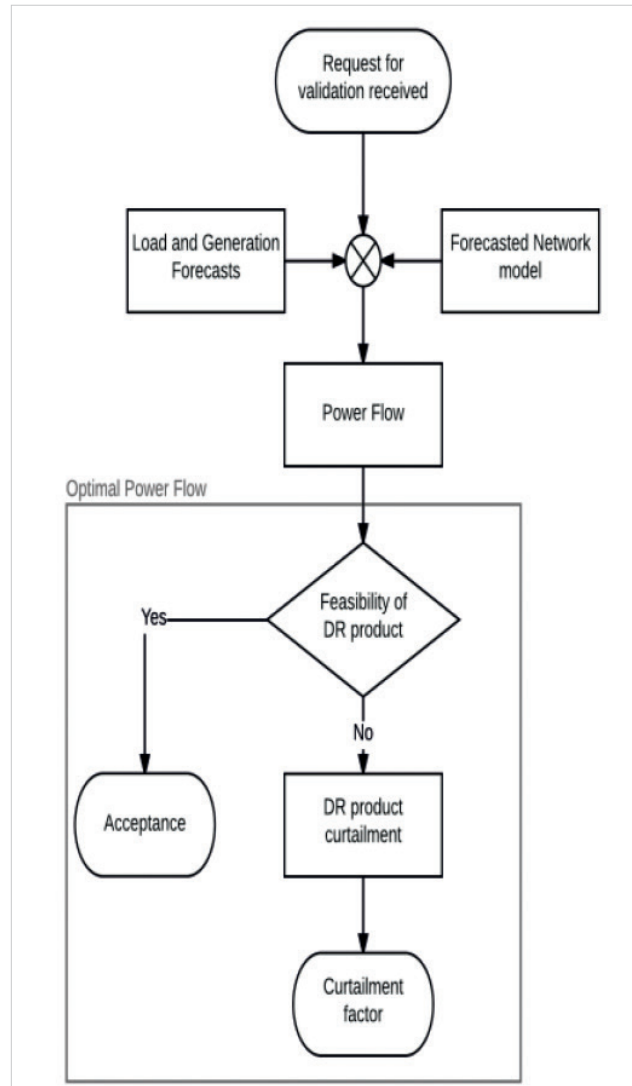

Figure 17: OLV diagram

giving the consensus to the activation request of a CRP product by the TSO or other deregulated players (e.g. balance responsible party). It is the equivalent of the off line validation, but it is based on a different time framework. This function runs on demand, every time there is a request for a CRP activation. The core

procedure is almost the same as in the OLV tool. Due to the close to real-time use of this Tool (i.e. 15 minutes before the deployment), the real-time measurements and description of the system are used (topology, load, generation etc.). Figure 18 illustrates the sequence of the RTV, presenting an example of a CRP request for activation.

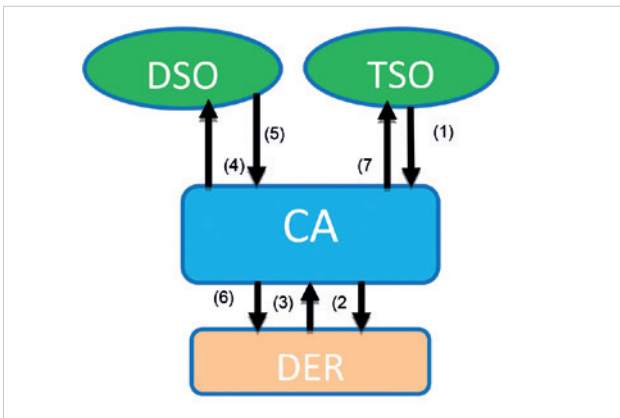

Figure 18: Sequence of CRP validation in RTV

Action	Time
The TSO sends an order to CA stating the quantity (+/- kW) of the CRP	10.00
The CA sends a status request to the DER	
<ul style="list-style-type: none"> - On/Off - Temperature - Power Consumption - etc. 	10.02
The DERs return the operational status to the CA	10.04
The CA asks the DSO for validation of the CRP	10.06
The DSO runs a power flow calculation and approves or curtails the request	10.06 - 10.08
The CA activates the DERs and confirms the activation	10.15

This procedure depending on the scalability of the system could be applied on single distributed energy resource (DER) unit or on an entire LA.

COMMERCIAL AGGREGATOR

The Commercial Aggregator is defined as the player who buys and sells energy and controllable power (flexibility) in the electricity markets or via other forms of trading (bilateral contracts, call for tenders, etc.), by modifying the consumption patterns of their customers. This modification is achieved by sending different incentives to the consumers or by “directly” controlling the consumer’s consumption via active power set points. The SRPs are formed by means of price incentives, triggering the load re-profiling of the prosumers. The CRPs demand a more immediate and direct control, so their activation is performed by means of direct control signals (power set-points). In response to the signals, the consumers change their consumption level at specific time intervals. The CA will communicate with the consumers thanks to a communication device, which becomes the gateway between consumer and Commercial Aggregator. This device acts as an Energy Management System (EMS), which is in charge of the coordination of load, generation and storage at consumer premises. Triggered by signals received by the CA, the EMS will reschedule the consumption profile of the system, running a specific optimization algorithm.

The Commercial Aggregator Architecture consists of the following tools:

- Consumption Forecasting. This tool is used to forecast the consumption of the prosumers
- Consumer Segmentation (Clustering). The objective of this function is to classify the prosumers in the Commercial Aggregator's portfolio into several groups, defined as clusters. Every cluster comprises a group of prosumers within the same Load Area, sharing some characteristics such as a similar consumption pattern, kind of contract, kind of appliances included, existence of Energy Storage Systems (ESS), etc. One load area can include more than 1 cluster, depending on the diversity of the prosumers that are connected there.
- The clusters are a commercial segmentation, are used by the CA in order to better handle its portfolio of consumers and to simplify the calculations. Since every cluster consists of consumers having a similar behavior, an average consumer per cluster may be assumed.
- The Flexibility Forecast Tool. This tool is simulating the behavior of the consumers under different price and volume signals. In fact, the algorithm is run for an average consumer from every cluster. Thus, after forecasting the response of this average consumer, the aggregated response for the whole cluster can be obtained.
- Market forecasting. This function forecasts the market price of the sold and purchased electricity.
- The Commercial Optimal Planning Tool. Given the flexibility forecast, as well as the market price forecast, the Commercial Aggregator can schedule the optimal bidding policy, by using the Commercial Optimal Planning Tool. This tool calculates the optimal incentive and bidding policy, in order to maximize the profits of the Commercial Aggregator.

The functions included by the Commercial Aggregator are presented in Figure 19

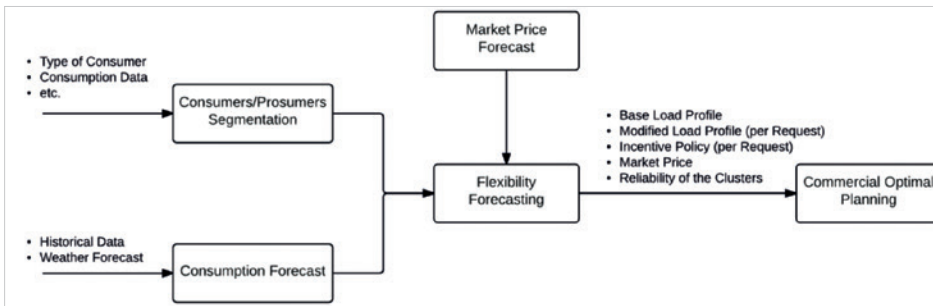

Figure 19: The different modules of the Commercial Aggregators

3.4. Digital use cases for retailers and aggregators

3.4.1 Dynamic pricing and Demand Response Management

SHORT FACTS ON THE LINEAR PROJECT

In this chapter, we discuss a demand response project with 250 families in Flanders, Belgium, which innovative technologies, business cases and user acceptance on a large scale. The full results of the Linear project are available on www.linear-smartgrid.be. The households had smart washing machines, tumble dryers, dishwashers, domestic hot water buffers and electric vehicles. In addition, the flexibility was used to balance the portfolio of a balancing responsible party, and keep the voltage of the local network within limits.

Partners in the project covered the entire value chain, with research institutes like Energyville, iMinds and Laborelec, the two DSO's Eandis and Infrac, the energy supplier Luminus, the in-home management systems of Fifthplay and the suppliers of the home appliances. The project recently finished in 2015.

SHORT SUMMARY OF MAIN RESULTS OF THE PROJECT

Dynamic pricing

First the families were confronted with time-varying electricity prices. Instead of the classical day/night tariffs, the day was divided into six time blocks, where the price was depending on the energy market price. The consumers responded in two different ways. The first group got the prices day ahead on a tablet and they could manually shift their consumption away from the peak hours. The second group could automatically react by indicating a time on their appliance e.g.

to which their laundry should be finished. The domestic hot water buffer was automatically programmed to charge outside the peak hours as well. Reacting manually on the time-varying prices clearly required too much effort, and the users in this group gave up quite quickly. However, the automatic responding people perceived the Linear system as without any loss of comfort and their consumption was often shifted from the evening to the night. Domestic Hot Water buffers appeared to be the most interesting device, as these have a large consumption which can easily be shifted without loss of comfort. Energy cost savings of around 20% for dishwashers, 10% for washing machines and tumble dryers and 5% for Domestic Hot Water buffers were found.

Time-varying prices can shift consumption if the behavior of smart appliances is automated.

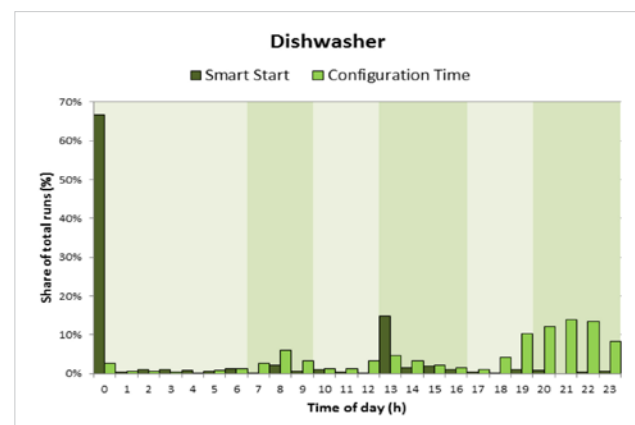

Figure 20: Shifting of dishwasher consumption without control (light green) towards the night time and afternoon with PV (dark green)

Balancing

A second case that was investigated with the families was balancing the portfolio of Balancing Responsible Parties (BRP). More specifically, errors in wind prediction were removed by (de)activating the households consumption. One of the results of a cluster of households is shown in Figure 2. Clearly the flexibility is asymmetric, where it appeared to be a lot more effective to remove positive unbalances (by activating consumption) than negative unbalances (by delaying/deactivating consumption). A cluster of flexibility was able to react very fast to a requested power output, where the limitations were mainly due to the available amount of flexibility. Market simulations showed potentially large benefits for balancing service providers with residential flexibility in their portfolio.

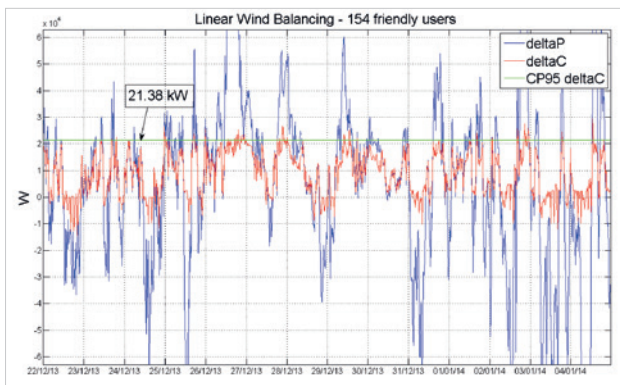

Figure 21: Imbalance (blue) and consumption change (red) of the cluster of households. Green line is the 95th percentile of the limit of the available flexibility

Voltage control for the DSO

Finally, flexibility at the consumer side was used to improve the power quality of the local network and extend the lifetime of grid assets such as the transformer. Results of the project showed that these effects are extremely feeder-dependent, which makes a general conclusion about this business case difficult. For the extension of the lifetime of the transformer, the measurements in the pilot revealed that a business case would be very hard to achieve. For the voltage control case, the result of the pilot showed that using residential flexibility can improve the voltage in the feeder. However, in the pilot test a lot of flexibility was needed to achieve the desired effect, which resulted in the fact that often no flexibility was available when actions had to be taken. We conclude that controlling the local grid power will not be a main driver for residential demand response. Nevertheless, a combination with a market oriented case like time-of-use pricing or balancing could be potentially very interesting.

Controlling the LV grid voltage will not be a main driver for residential demand response

Benefits and challenges of digitalization

The in-home space is one of the environments which is expected to rapidly evolve into a connected system. The Linear project provided crucial practical experience and challenges for the evolution towards such systems.

For controlling the smart appliances in the project, the Home Energy Management system of the Flemish company Fifthplay was used, which was developed and tested within the project and now commercially available. For data communication, the Linear system used the participants' high-

speed internet connection. A zigbee plug network was installed to monitor the energy consumption at appliance level. Whenever possible, the control signals were sent via Ethernet connection, in some cases PLC communication was used as well.

Technically, several barriers had to be overcome to roll out the system with the households. One of the major issues was the lack of commercially available technology to control the smart starting of the devices. Therefore, the Linear project developed a controller for appliances like the domestic hot water buffer and the washing machine.

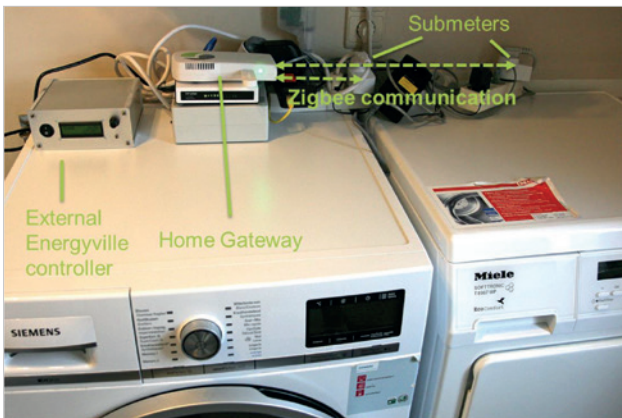

Figure 22: Picture of the laundry room of one of the participants.

One of the other challenges was the availability of the communication between smart appliances and gateway. This includes non-technical losses, like users disconnecting plugs, causing an interruption in incoming data. Every house can be different in this respect, location of the meter cabinet and smart appliances, concrete walls blocking the wireless communication etcetera. Finally, regulatory barriers exist for residential demand response to participate in the market. For this chapter we refer to the project results.

In the coming years, we expect more and more smart appliances to be connected to the internet-of-things. The benefits of dynamic pricing and automated demand response at residential level are clear, however smart appliances did not yet find their way into the home of the average consumer. The technology development for this is ongoing, however challenges still exist to develop cost-effective and reliable communication that is ready for a widespread commercial rollout.

[1] www.linear-smartgrid.be

3.4.2 Smart houses in a smart grid environment

The SmartHouse/SmartGrid project has affirmed the European goal of providing clean, secure and affordable energy, and set out to provide technical solutions that facilitate the integration of higher shares of such energy supplies, in this case decentralized renewable electricity sources. The project goal was to validate and test how ICT-enabled collaborative clusters of flexible smart houses can help to achieve the needed radically higher levels of sustainability and energy efficiency in Europe.

A brief problem statement for the project is summarized in the following:

The SmartHouse/SmartGrid project [1] goal was to design, develop and validate new ICT-based, market-oriented and decentralized control concepts for the electricity system in Europe. These concepts developed support the efficient integration of energy loads - such as private homes - and distributed generators - such as small renewable energy sources or CHP units - into a service-oriented electricity infrastructure.

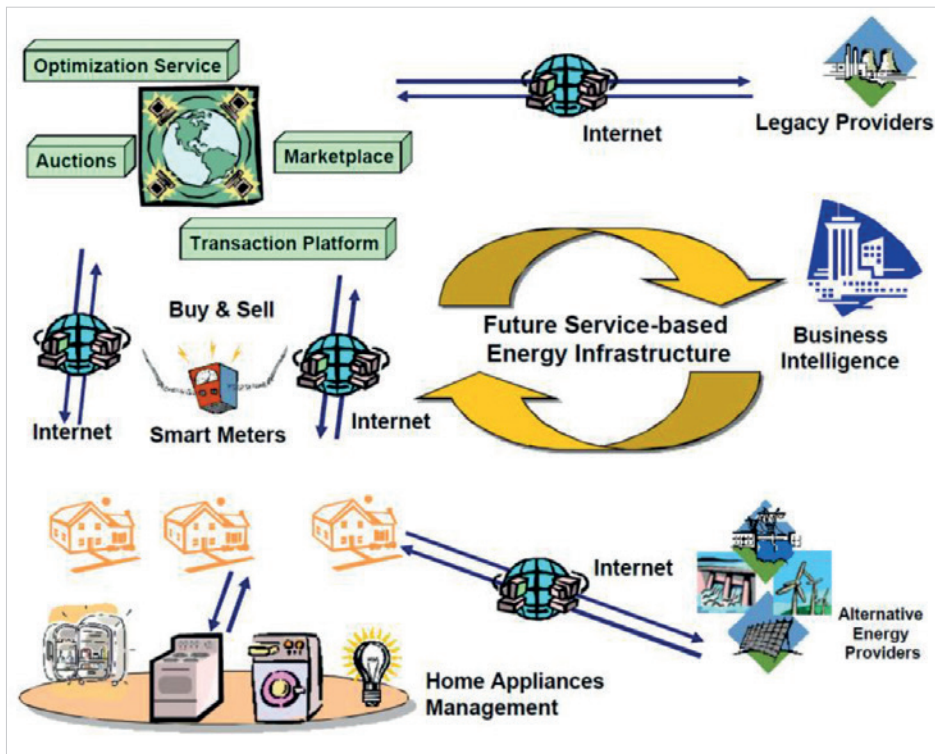

Figure 23: Service-based ecosystem according to SmartHouse/SmartGrid vision [3]

In SmartHouse/SmartGrid, three trials [2] have been realized with complementary focus points as seen in Figure 18. The intention of the project was to introduce a holistic concept for smart houses situated and intelligently managed within their broader environment. Smart houses should become capable communicating, interacting and negotiating with the energy utility on the one hand and with the single consumer devices and appliances on the other hand. Through this, the customer's flexibility in electricity usage (and generation in the case of a prosumer) can be exploited so as to raise the overall energy efficiency in the grid area.

The technologies developed within the project were supposed (i) to be based on available open industry standards from both the ICT and energy sectors and (ii) to employ communication

and computing capabilities that are already in widespread use in mainstream home and working environments. This is important for keeping implementation costs low and for being able to test the technologies in the field during the project.

The technological challenges that the SmartHouse/SmartGrid project aimed to address were the following:

The envisioned SmartHouse/SmartGrid technologies are intelligent agent and e-market techniques for decentralized control and optimization at the network level. This comprises:

- Intelligent customer-interactive in-house technology that provides energy management for smart houses using real-time information such as dynamic tariffs and metering data

- Interface technology that technically aggregates and integrates smart houses into larger intelligent local networks interacting with the electricity grid
- Agent-based distributed control technology that is able to monitor and optimally control large numbers of energy consuming and producing devices in a fully decentralized and bottom-up fashion
- Electronic market and forecasting techniques that automatically optimizes the operation of clusters of smart houses on the basis of negotiated needs, priorities, and interests

Smart houses should become capable of communicating, interacting and negotiating with energy utilities on the one hand and single customers appliances on the other hand.

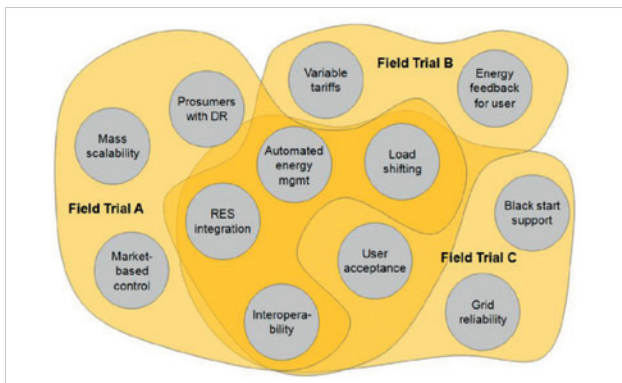

Figure 24: Complimentary focus points of the SmartHouse/SmartGrid trials [2]

Each of the three SmartHouse/SmartGrid field trials was designed to deliver proof of concept of a specific aspect of the new technology:

- Scalability: The capability to handle the large-scale communication, negotiation and information exchange between many thousands of smart energy devices at the same time (carried out in the Netherlands).
- Usability: The capability to intelligently interact with the customer (such as home owners) and deliver optimal home energy management as a response (carried out in Germany).
- Applicability: The capability to control smart energy devices in a fully decentralized and bottom-up way such that optimum energy efficiency and security of supply at is achieved (carried out in Greece).

On the basis of the results and experiences from these field experiments, another project objective was to define a roadmap to mass application of the SmartHouse/SmartGrid technology.

The project lends from several smart grid concepts developed at different research institute. These are, namely, the following three concepts:

- The PowerMatcher developed at the Energy Research Center of ECN and further developed by TNO.
- Bi-Directional Energy Management Interface BEMI developed at the Fraunhofer Institute for Wind Energy and Energy System Technology IWES
- The MAGIC system developed at the Institute of Communication and Computer Systems at the National Technical University of Athens

These three technologies were further developed within the project, and synergies between the approaches were identified. They all share one

control paradigm which can be summarized as follows:

The concept of the project is to combine centralized and decentralized control approaches with the following philosophy: Let the end-customer decide as much as possible within his or her private grid. Therefore, offer the end-customer the online tools with appropriate boundary conditions and incentives to optimize his or her energy interface to the outside world according to actual (dynamic) prices and energy efficiency considerations that reflect the realtime needs of the public grid. To this end, provide centralized information but allow for decentralized decisions.

The procedure for developing the SmartHouse/ SmartGrid technologies followed a stringent approach. First, a set of business cases was defined that served as a reference for evaluating the usefulness of the technologies.

-
- [1] Dimeas, S. Drenkard, N. Hatziargyriou, S. Karnouskos, K. Kok, J. Ringelstein, and A. Weidlich, Smart Houses in the Smart Grid: Developing an interactive network, IEEE Electrification Magazine, pp. 81-93, March 2014, doi:10.1109/MELE.2013.2297032.
 - [2] S. Karnouskos, A. Weidlich, K. Kok, C. Warmer, J. Ringelstein, P. Selzam, A. Dimeas, and S. Drenkard, Field Trials towards Integrating Smart Houses with the Smart Grid, in 1st International ICST Conference on E-Energy, 14-15 October 2010 Athens Greece.
 - [3] K. Kok, S. Karnouskos, J. Ringelstein, A. Dimeas, A. Weidlich, C. Warmer, S. Drenkard, N. Hatziargyriou, and V. Lioliou, Field-testing smart houses for a smart grid, in 21st International Conference and Exhibition on Electricity Distribution (CIRED 2011), Frankfurt, Germany, 2011.

3.4.3 Smart charging of electric vehicles

FINESCE is a project funded within the second Phase of the Future Internet PPP of the European Commission. Goal of this PPP was the development of a cloud based platform to develop service across different business sector. FINESCE expanded the platform in the direction of energy services creating a multi-layer structure able to support rapid development and implementation of energy services starting from open source software.

The open source development initiative is still now running within the Forschungscampus (Research Campus) initiative managed by RWTH Aachen and called Flexible Electrical Network (FEN). A consortium of about 20 companies is supporting further developments of this platform.

Here we report some significant use cases developed within the project.

SMART CHARGING OF A LARGE FLEET OF ELECTRIC VEHICLES

The trial aims at setting up a charging optimisation system for domestic home charging taking into account several criteria such as customer experience, grid friendliness and renewable energy usage. Two kinds of wireless access technologies have been evaluated during conduction of the trial: WiMAX and LTE.

The heart of the charging optimization system was located at Watherford Institute of Technologies (WIT) premises in Waterford, Ireland, hosting a central database containing all data collected during the trial as well as configuration data to be taken into account by the charging optimisation algorithm. The management and control software of the Electric Vehicle Supply Equipment (EVSE) are being developed and hosted by WIT. Additionally an API is provided allowing access to trial data for internal partners and also SMEs or other third parties that want to use these data.

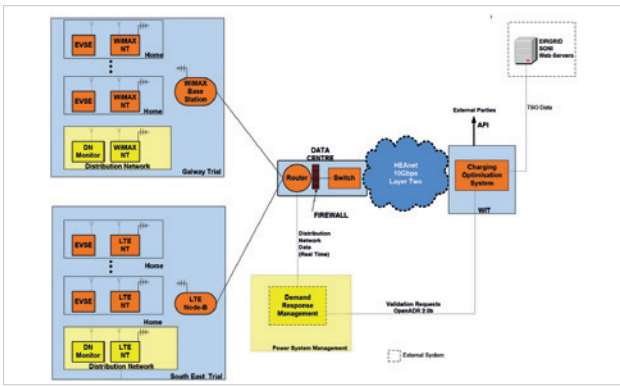

Figure 25: Smart Charging trial Architecture

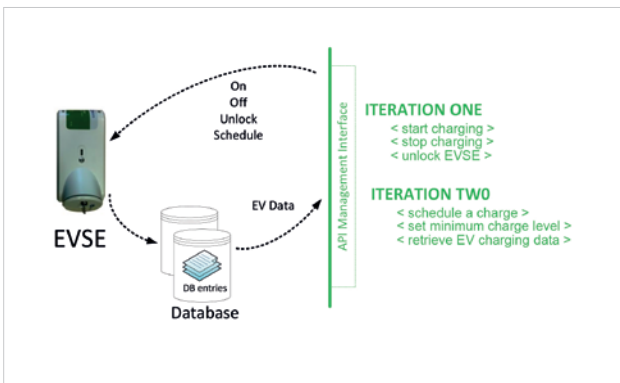

Figure 26: FINESCE EVSE API

The architecture of the trial is summarized in Figure 25.

The external API of the charging point is summarized in Figure 26. Different roles and permissions can be assigned to the different end-user groups to effectively manage the access to functionality and data.

The main results of the trial are here summarized. The technical experimentation concerned electricity balancing, showing how both temporal and geographical supply-demand imbalances, resulting from the ever increasing use of renewable power in electricity grids globally, can be addressed by having users' energy demand (in the form of when they may charge electric vehicles) track the supply of energy from renewable sources, the opposite of the conventional approach, in a fully operational charging optimisation system (COS), serving real customers. Two use cases have been studied:

- Grid emergency: this is where a fault results in a major drop in power generation or supply, and emergency action to reduce electric vehicle charging load in order to avoid blackouts. COS has been designed to ensure that a malicious user cannot initiate a grid emergency event. The critical parameter in this case is the charging optimisation system's speed of response, the faster the response the greater the economic value to grid operators. Tests showed that average response times of unencrypted and encrypted event messages were 462.2 ms and 166.8 ms respectively, which fulfils the requirements set by the DSO/TSO.

- Supply-demand balancing: tests have been performed on the how quickly electric vehicle charging can be controlled. Response times of 300ms on LTE and 640ms on WiMAX were measured towards the real electric vehicles in the trial. Large-scale tests performed towards 200, 1000, 5000, and 20000 simulated electric vehicles showed that COS processed the data streams from the electric vehicles in 1.07, 3.12, 3.60, and 11.83 seconds, respectively. COS's distributed architecture means that it can scale to support more electric vehicles.

The latency and availability of the communications between COS and the electric vehicles was measured. The latency was below 1 second, which is very satisfactory. The overall communications availability was found to be 98.5% meaning that about 1.5% of potential interruptible load cannot be interrupted on average due to communications problems.

3.4.4 Neighborhood energy management

The following use cases have been developed as part of the FP7 COOPERATE as part of the call Energy Positive Neighborhood (see Deliverable D.1 at www.cooperate-fp7.eu).

3.4.5 Use cases

1. Real-time Monitoring of the Consumption of a Neighbourhood
 - Short description: Measure, aggregate and visualize the consumption of the neighbourhood in real-time
 - Concept: The task faced by Neighborhood Manager and the working group is to develop a real-time monitoring application service that will integrate information from multiple energy systems, thus enabling increased awareness and decision support at all levels: Neighborhood Energy Manager (NEM) , Facility Manager (FM) and users/

occupants. The service will be leveraged further in other application services such as UC2 - demand and generation forecasting, UC3 - grid -v- local optimization and UC4 - demand response services.

- Value proposition: The real-time monitoring of the neighbourhood is the first step for the other added value services such as DR or DSM. It is commonly admitted that the monitoring itself contributes to reduce up to 20% the global energy consumption
2. Forecasting of the consumption and local generation
 - Short description: Forecasting the consumption of the neighbourhood and the local generation, hourly ahead, day ahead or year ahead helps the neighbourhood to manage efficiently the energy cost, the interaction with the grid and the market. If shared with the DSO, it is providing visibility to the Utility to better dispatch the power.
 - Concept: The service will provide energy consumption and generation forecasting capabilities to the neighborhood energy manager, facility manager and users for assessing the future energy consumption and planning local power generation. It will be used to identify possibilities for improvements to the existing thermal and electrical systems operation in order to improve efficiency of the neighbourhood. The service will be used as an input for optimization and demand response, to predict in an optimal manner the future energy demand and cost.
 - Value proposition: The ability to forecast energy demand and local power production will give the neighbourhood a powerful

tool in negotiation of energy purchase contracts and should enable purchase of electricity, gas and fuel on more favourable terms. Reliable forecasts will also enable more reliable demand response, which will add value as reliability in demand response attracts a premium.

3. Flexibility services to the market

- **Short Description:** The Neighbourhood is providing a flexibility service to the energy market, participating to DR programs, as a single entity. This is generating additional revenue for the neighbourhood.
- **Concept:** The task faced by the NEM and his team is to oversee the operation of the neighbourhood infrastructure in acting as a flexible prosumer that can dynamically respond to price signals from the grid utility. The infrastructure includes on-site local generation, flexible load and storage capacity. The neighbourhood is connected to the grid and will act in an optimal manner in response to grid signals by utilising the demand response application service which itself leverages other services such as the real-time monitoring, the forecasting capability and the grid -v- local purchase optimisation capability.
- **Value Proposition:** Utilities provide incentives to electricity customers to reduce their consumption during periods of peak demand. Although the traditional approach for the business model is to compare DR against the historical amortized cost of a 'peaker plant' (usually combustion gas turbine - CGT), the value is also very much dependent on the regulatory context of each country.

3.4.6 Technology development needed to meet the challenges

The main challenge beyond the implementation of the proposed use cases has to do with data interoperability. Buildings are at the crossing point of a variety of sectors from real estate to energy systems. For this reason it is very hard to find a valuable data model that can support the interaction among all the players. Furthermore, in the context of a neighborhood it is also possible that multiple operators are present and they may refer to different IT/cloud infrastructure. This poses a system of systems challenge. The project COOPERATE proposed in this direction the development of a web service called Neighborhood Information Model that acts as a translator among different formats and as interface among different cloud systems. A description of the concept can be found in the deliverable D1.2 of the project (see www.cooperate-fp7.eu).

NIM is a meta-model built with the goal to be open and extensible. An idea of how the model can evolve is reported in Figure 27: this is a meta-model for NIMs because it does not contain any information about the concrete content of a NIM but shows a way to structure the huge amount of data which must be handled. The NIM itself contains an identifier to uniquely identify the neighbourhood. The data stored in a neighbourhood is categorized and not stored as flat data entries. This approach is similar to the approach shown in Deliverable 3.1 of the SEMANCO project (D3.1 Report on the Accessible Energy Data, 2012) where categories are used to structure the data of a single building in a BIM. Thus, each NIM has several categories to group the data entries. In addition, categories can reference each other via a weak link to reuse data structures defined by categories. The weak link is shown in green and modelled as an association. In fact this association does not directly reference the category but an identifier of the corresponding

category that can be used to resolve the linked category. Thus not all categories are directly loaded but can be resolved on demand.

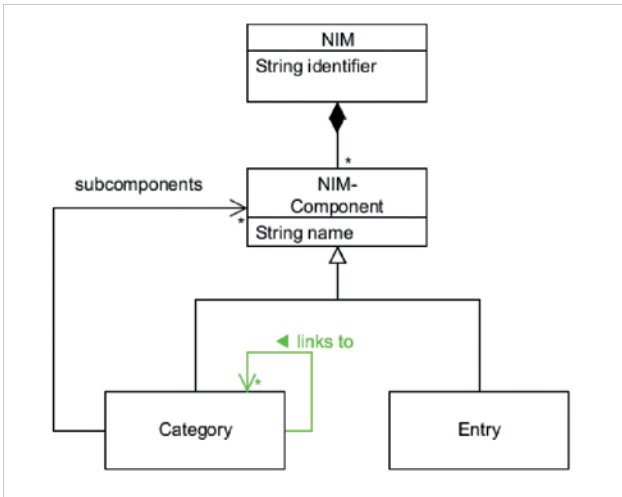

Figure 27: The main parts of the NIM. The concept of scopes as well as the abstraction of concrete data is shown.

The concept of scopes follows two design principles, “divide and conquer” and “modularity”. The division into scopes on the one hand provides a tree-like structure on the data but also leads to a better performance since a smaller amount of data can be requested, i.e. all the data within a scope, and therefore becomes manageable. Additionally the scopes provide a good concept for modularity since new scopes can be added easily and therefore the overall model stays extensible. Each category providing a new scope may have subcategories or entries. More details about the specific entry can be found in the already mentioned deliverable.

While NIM has been defined as an extendible concept, a first significant set of features have been already implemented as part of the project. Figure 28 shows the available categories and the link among them. The defined entries are based on the SEMANCO data model, which was extended by some fields to match the requirements.

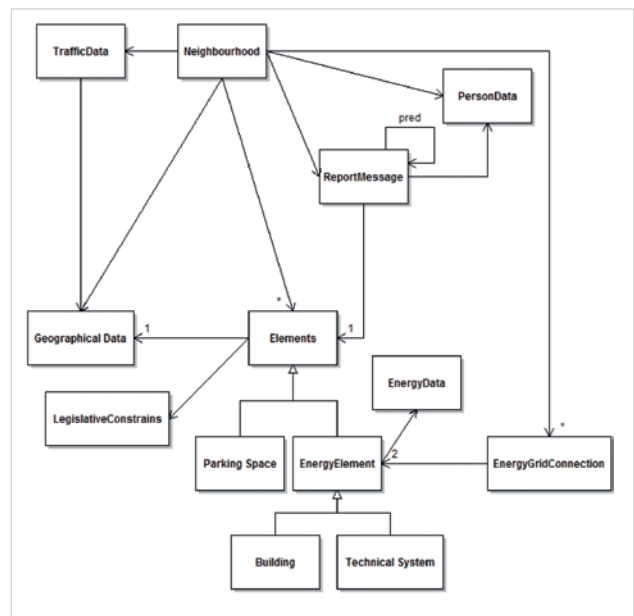



Figure 28: available categories, and the links between them.

NIM has been implemented as web service. This allows the link of data among different cloud services using different data representation. Each cloud accesses the data using the NIM representation as a bridge allowing interoperability among different data models. In the course of the project, the concept has been tested exchanging information among three different data platform such as Urban Power from EMBIX, IoT platform from INTEL and NICORE from Cork Institute of Technology.



This need of interoperability also shows the value of adopting open-source open-interface cloud platforms to bring the level of interoperability even higher in the software architecture beyond the simple data compatibility. An experiment in this direction is under way within the Future Internet PPP of the FP7. In this context a set of open specifications, called Generic Enablers has been specified constituting the so-called FIWARE platform. Information about this solution can be found at <http://catalogue.fiware.org>. In the energy sector, the FIWARE platform has been extended with another set of open specifications called Domain Specific Enablers within the project FINESCE. This list of open specification can be found at <http://finesce.github.io>

The need for interoperability shows the value of open-source open-interface cloud platforms to go beyond simple data compatibility.



3.5. Digital use cases for retailers and aggregators

3.5.1 Local Energy Markets

The trial site of this part of the FINESCE project was implemented in Terni, Italy by ASM Terni (the local DSO) on a MV/LV branch network with a high presence of distributed energy resources, which are difficult to manage due to the variability of external factors such as weather conditions. Consequently, as side effects, there arise both reverse power flows through the secondary substation and reduced operational efficiency of the involved components (e.g. power losses in MV/LV transformers and reduced lifecycle). The main objective of the marketplace application is to enable a demand response mechanism aiming at the minimization of reverse power flow effects, by trying to shift the demand during peaks of production, through the active participation of the consumers, together with all the other marketplace actors (e.g. DSOs, Aggregators, Retailers).

The proposed marketplace application is enabled by a near-real-time smart metering infrastructure that provides the possibility to proactively face the problems of the grid, which occur due to the fluctuating power production in the LV network. The huge amount of data collected also from external sources and their analysis provides the possibility to understand how to align the consumption to peaks of production.

One of the main challenges of the trial was to collect the meter readings every 5 minutes. In order to deploy such a near-real time reading, it has been decided (for reasons of efficiency and time constraints) to adopt a meter with a GSM/GPRS modem.

Two types of meters have been tested. The first one was a Lennt P2 by Landis + Gyr Spa. The main features of this meter are:

- GSM/GPRS communication;
- collection of the load profile curves every 15 minutes with the possibility of implementing on-the-spot readings every 5 minutes;
- partial integration in the Advanced Meter Management (ARM).
- conforms to CE Directive, IEC EN 62052-11, EN 50570 series.

In a second stage a ZXF has been also tested. This is a smart meter which provides load profile curves every 5 minutes. The main meter output interface for automatic readout is GSM/GPRS or Ethernet. ZXF has a module that uses the DLMS protocol (Device Language Message Specification) according to IEC 62056 for data readout, service functions and parameterization.

Figure 29 provides an overview of the business relationships among the Actors of the Marketplace application, showing how the actors will operate in an energy market with the presence of the aggregator. Each Actor has been defined by a number. Each relationship is represented by a unidirectional arrow that departs from the active part/entity of the relationship and reaches the actor that receives the results of the relationship. Additionally, each relationship is also characterized by a code defined as follows:

- the first number is the reference (red number) of the Actors that supply the info
- the second number is the reference of the Actor that receives the info
- the third character is a progressive letter

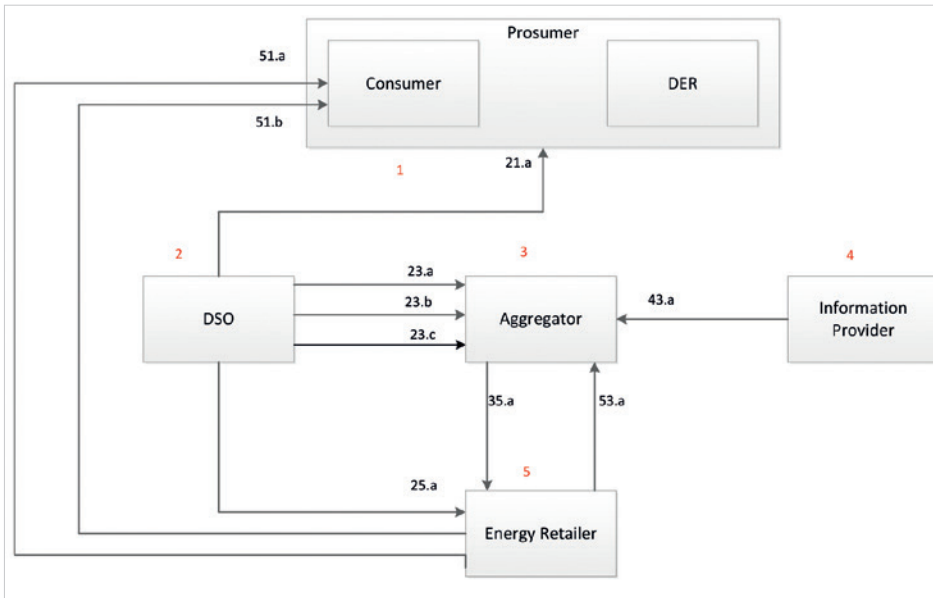

Figure 29: Actors Relationship

In order to simplify the diagram, the Prosumer in Figure 29 is depicted as an entity that incorporates two other actors, the Consumer and DER. Thus, any relationship that is valid for the Consumer or DER is also valid for the Prosumer.

Production Scheduling Adaptation

The factory field test regards a special demonstration plant, which will produce real goods in small series such as framework parts for the StreetScooter (electric vehicle). The production environment of the demonstration plant is available for research purposes and provides access to already installed intelligent information systems and technology (controller of machine tools, SAP ECC 6.0) and real-time transaction data (e.g. information about produced goods, material flow). For this purpose, an energy monitoring system is implemented by collecting a high amount of data via sensor technology (working with bus communication and deploying smart metering) within the factory. Energy data from energy suppliers outside of the factory, here

represented by the VPP stream, is made available for the demand-side to allow the production to react to shortages, price changes and other events.

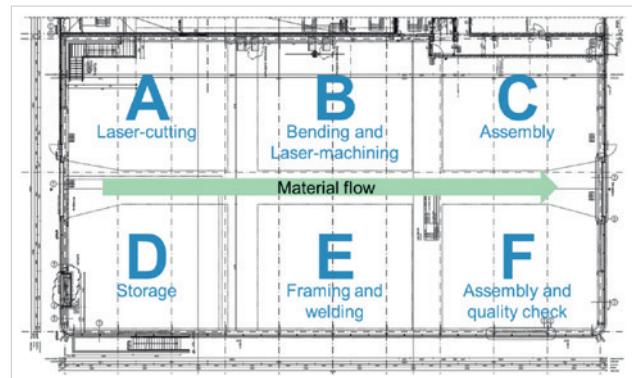

Figure 30: Schematic Overview of Material Flow and Factory Layout

Figure 30 gives an overview of the factory layout, which consists of six sections dedicated to specific tasks. Production flows are routed in a single direction through the factory in order to allow for improved efficiency. For monitoring of electrical energy, especially those sections with machine tools are relevant.

Material flow for production starts in the storage area, where the raw goods are kept. Sections A and B are only required for producing the StreetScooter steel frame, but not for other goods. Area C contains assembly stations for specific tasks and need to be realigned with changing production schedules. The StreetScooter steel frame is assembled in section F, whereby a quality check is performed. The steel frames are produced on demand and directly forwarded to the next production step in another factory also in the region of Aachen.

#	Sec.	Machine tool	Controller	Monitored
1	A	TRUMPF TruLaser 5030 fibre (incl. TRUMPF LiftMaster)	Siemens Sinumerik 840D	yes
2	B	TRUMPF TruBend 50855	TASC 6000	yes
3	B	TRUMPF TruDisk 4001	/	yes
4	B	Reis Robotics RV 60-60	/	yes
5	E	MAG Welding station	/	no
6	E	Framing station	/	no
7	C & F	Assembly stations	/	no

Table 5: Production Equipment in the Smart Factory

Monitoring device	Interfaces	Used on #
Weidmüller Power Monitor	MODBUS (RS485, max 1,200 bps)	1, 2, 3
Siemens SENTRON PAC3200	1x RS 485, 1x Ethernet	4

Table 6: Energy Monitoring Devices Deployed in Factory

Table 5 gives an overview of the production equipment being used in the factory. The four main consumers of electrical energy are monitored in terms of their status and energy consumption. The information is gathered directly from the machine tools - where possible - and additionally by external energy monitoring devices, which are described in Table 6. They connect to the local production database via Ethernet.

GE	Gei	Application	Deploy
Gateway Data Handling	Esper4-FastData	Data gathering	Locally
Gateway Device Management	Gateway Device Management	Data gathering	Locally
Complex Event Processing	Proactive Technology Online	Data interpretation	Cloud
Publish/Subscribe Broker	Orion Context Broker	Data interpretation	Cloud
Application Mashup	WireCloud	Data exploitation	Cloud

Table 7: GEs used in the smart factory

The ICT infrastructure in the factory mainly consists of three domains. On shopfloor level, where the data gathering happens, the machine tools and energy monitoring devices are connected via a LAN based on Modbus and PROFINET with the production site server, where the GE Gateway Data Handling and GE Gateway Device Management are deployed locally on a Dell PowerEdge M620 Blade Server. By means of a standing TCP Socket using the MsgPack framework, shopfloor information is forwarded to the Gateway server, whose role is to act as a connector between the secure local network and the internet. The gateway server pushes this information to the GE Complex Event Processing deployed in the FI-cloud. This GE is used in its default configuration with the GE Publish/Subscribe Broker, also used in the cloud. Lastly, the GE Application Mashup will be used to collect aggregated events coming out of the Complex Event Processing GE and provide them for the local ERP system.

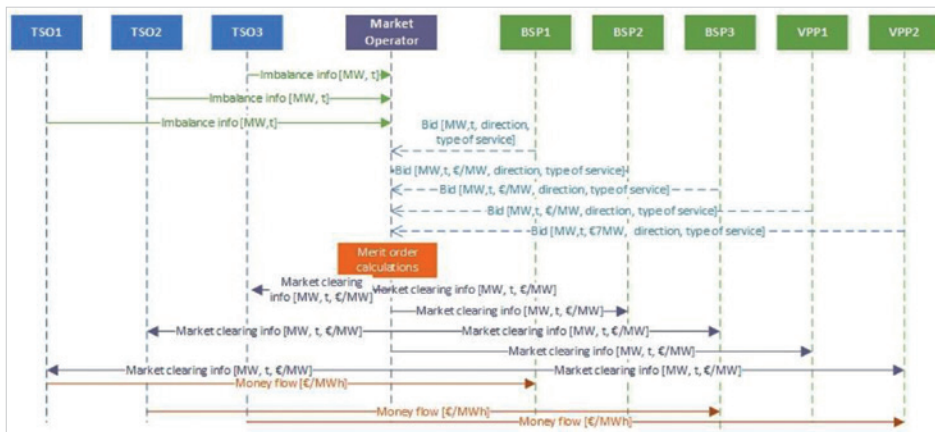

Figure 31: Overview of data exchanged among market participants

3.5.2 ICT tools for cross-border markets

The eBadge project connects several market players including TSOs, DSOs, MO, VPPs & energy customers via the project's ICT infrastructure encompassing various ICT tools such as a home energy hub, cloud, message bus, VPP, optimization and forecasting modules. All the ICT tools are integrated into a single system. The system enables a cross-border electricity balancing market to function. The system has been validated via several lab tests and field trials piloted in the trilateral region of Austria, Italy & Slovenia.

The data that are exchanged between the actors is summarized in the Figure 31.

TSOs are reporting data about imbalance to the Market operator. These data include required power [MW] and timeframe [t] in which it should be delivered. On the other hand, balance responsible parties (BSP) and Virtual Power Plant (VPP) operators can bid to supply the required power. Bid information includes capacity [MW], timeframe [t], price €/MW, direction (upward or downward bids) and type of service (RR, FRR, day-ahead, etc.). Based on information received, market operator calculates merit order and dispatches signals for activations to selected players. Based on data received, the BSPs and VPP

operators dispatch required capacity in selected timeframe. TSOs in the end provide payments for delivered energy.

The eBADGE project mainly brings 3 benefits:

1. Halving the costs of balancing services;
2. Optimizing the energy value chain thanks to VPPs contributions;
3. Liberalizing energy data (the telecom operators can facilitate the market by undertaking this task as showcased in eBADGE).

The necessary technological development and implementations are the following:

- ICT communication network;
- Suitable communication infrastructure (4G);
- Suitable communication protocols (eBADGE Message Bus);
- Cloud based architecture (servers);
- Home energy Hub (communication box at end consumer).

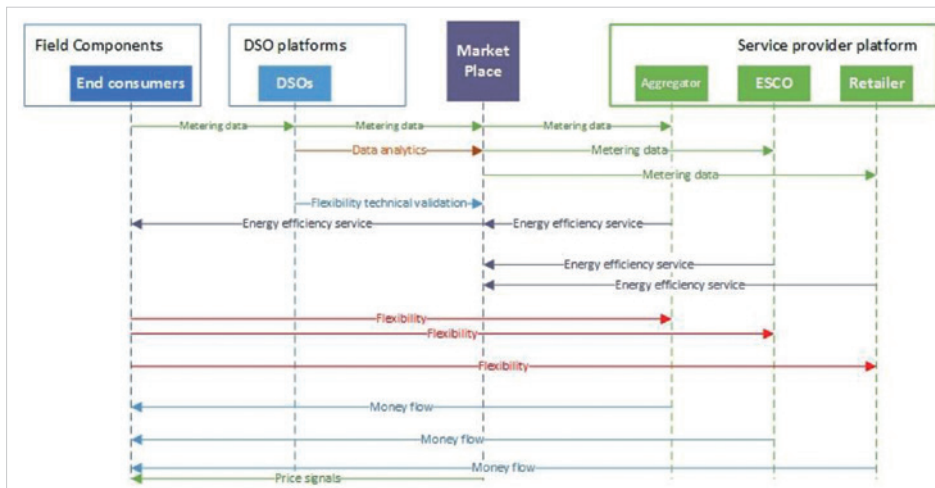

Figure 32: Data flow among participants with focus on more active end-consumer

3.5.3 The DSO as market facilitator

The Flexiciency project enables the necessary digital technology developments for DSO's, who will act as market facilitators by making their energy data available on a platform operating like a virtual marketplace. Here other market players can access the data and deploy it in their own business operations. Market players that are foreseen to take an interest in using the platform in order to access and use the data could be ESCOs (Energy Service Company) and new market entrants.

The data flowing between the actors is the following. The main focus is on end-consumers more actively participating in the energy exchange.

FLEXICENCY will ensure service providers get equal access to metering data from end consumers in a non-discriminatory way and hence be able to offer energy efficient services. DSOs will perform technical assessment of each service.

Information that are sent are metering data, signals for activations, price signals and money flow.

Market place serves as a central, cloud platform to catalyze the interactions between all the relevant stakeholders in an open and standardized way and to encourage a cross- player access to innovative energy services.

The main benefits of FLEXICENCY are expected to be the enhanced market opening, on one hand, which means easier access to the market for new market entrants and on the other hand, the new services created based on the available data. Services such as advanced energy monitoring, local energy control and flexibility services.

Necessary software/hardware:

- ICT communication network;
- Suitable communication infrastructure;
- Suitable communication protocols (common language);
- Peer to peer communication;
- Standardized interfaces;
- Cloud based software architecture;
- Field components (local meter interfaces, energy boxes and other actuators).

3.5.4 The Universal Smart Energy Framework

ONE COMMON MARKET STANDARD FOR A EUROPEAN SMART ENERGY FUTURE

The Universal Smart Energy Framework (USEF) has been developed to drive a fast, fair and lowest cost route to an integrated smart energy future. By delivering one common standard, it enables cost-efficient connectivity of all smart energy projects and technologies. Its market structure, rules and tools for the commoditisation and trading of flexible energy use work with different existing energy markets. Those markets become integrated and enabled for flexibility trading by adopting USEF and, in turn, this encourages energy delivery and usage at lowest cost and highest efficiency. Designed to offer fair market access and benefits to all stakeholders, USEF defines their individual roles and responsibilities, how they should interact, and how they can benefit by doing so. As well as reducing the congestion challenges faced by grid operators, it offers commercial opportunities to developers of innovative smart energy projects, products and services, and financial incentives to end-users who are willing to be flexible about when they consume energy.

USEF is developed, maintained and audited by the USEF Foundation, a partnership of key players in the smart energy domain: energy suppliers, network operators, electrical equipment manufacturers, consultancies and ICT companies. It was founded by ABB, Alliander, DNV GL, Essent, IBM, ICT and Stedin. The shared experience within the smart energy industry has enabled us to understand both the scope of the opportunity provided by flexibility and the need to join forces across roles and boundaries to realise it. We believe that this is the optimum way to achieve a unified smart energy future that offers benefits to everyone involved.

The complete USEF specification can be downloaded free of cost from <https://www.usef.energy/Home.aspx>

THE TOOLS AND THE RULES OF EUROPEAN FLEXIBILITY TRADING

Utilising flexibility to reduce stress on the grid and improve energy efficiency requires that it is commoditised. The system and mechanism for achieving this have to work across existing local, national and international markets and be fair and transparent, while recognising that there are differences between markets. USEF aims to address this by delivering a market structure for flexibility that will sit on top of most energy markets and defining the roles and guidelines required for it to function effectively. There is also a sample implementation which acts as a reference, providing practical information and a baseline standard to organisations interested in joining the market. USEF is the only framework of its kind offering a holistic, commercially neutral solution for integrated European flexibility trading.

ENSURING THE WHOLE IS GREATER THAN THE SUM OF ITS PARTS

Innovation is imperative to the future of smart energy and there are already a multitude of technologies, ICT systems and pilot projects underway. To be successful, these must ultimately be integrated so that electricity can be produced, transported and used in the most efficient way. To achieve international consistency and avoid wasting time and money reinventing the wheel, or piecing together incompatible parts later, we must all work to a common standard. USEF delivers this, providing a solid foundation which encourages innovation whilst ensuring that the whole will always fit together.

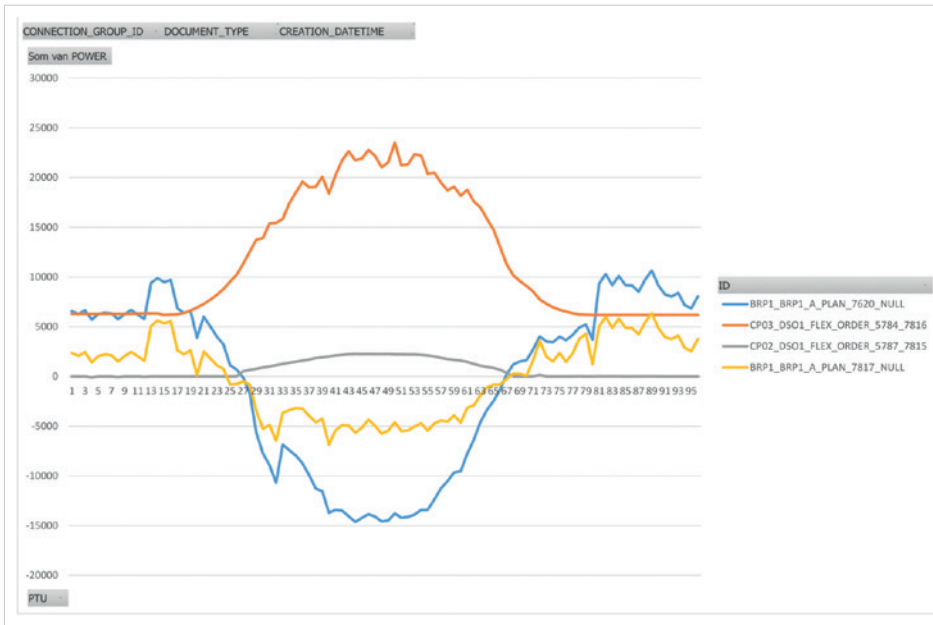

Figure 33: Example of USEF flexibility trading on a local market.

COLLABORATING FOR THE COMMON GOOD

Smart energy provides significant opportunities to everybody involved in the electricity system, from generator to user. To be successful, the benefits to all stakeholders must be defined and it is essential to have a level playing field and a single set of rules. Only this approach can drive the motivation and participation required to unlock flexibility. The size and international nature of the challenge require a common approach, without commercial or political bias, and this makes it beyond the capability of any single organisation or government. As a collaborative organisation, the USEF Foundation has been able to frame a shared goal and deliver a future-proof solution that could benefit everyone and connect all technologies, projects and local, national and regional energy markets.

MARKET SOLUTION RATIONALE

There are multiple stakeholders with an interest in the flexibility resulting from Active Demand

and Supply (ADS). Their interest in flexibility is formalized in 18 flexibility services defined by USEF. Each of them has its own purpose and characteristics in terms of timing, volume, location, accuracy, and so forth. Flexibility can be derived from various types of ADS from industrial down to residential. The challenge is to optimally divide the available flexibility over the different flexibility services at each point in time. What is considered ‘optimal’ may differ considerably among stakeholders.

Optimizing a smart energy system requires weighing not only the importance of stakeholders’ wishes, but also each of the alternatives. These alternatives are often part of the energy system as well, such as delaying the charging of an electric car by a few hours. Sometimes, however, these alternatives lie in another domain, such as taking the bus or staying at home. The importance of the alternatives outside the system cannot be measured based on physical parameters within the system. This makes it impossible to design

a control system that optimizes the division of flexibility over the various stakeholders based on physical parameters. Moreover, the alternatives may change over time, making the control system's scope undefined.

The only way to overcome this issue is to capture the importance of these wishes in a neutral parameter that expresses the value it has for each stakeholder. By monetizing this importance, stakeholder wishes can be evaluated on an equal basis. This enables each stakeholder to compare the cost of the desired flexibility with that of the alternatives. This in its turn enables stakeholders to negotiate the price for the desired flexibility to the maximum that is defined by the costs of their alternatives.

BENEFITS AND CHALLENGES FOR DIGITIZATION

Privacy & Security in USEF

The introduction of smart energy systems will create an explosion in the amount of energy usage data captured, from which a wealth of personal information can be distilled. Smart energy systems—like most complex information systems—deal with sensitive data and therefore require effective measures to preserve security and privacy. Privacy and security are system-wide issues; the protection of individual subsystems and components is not enough. The system is only as strong as the weakest link, and there is no way to realize a sufficiently large market for smart energy products and services if privacy and security issues undermine Prosumer trust. USEF is therefore designed with privacy and security in mind.

The Framework Implemented

The USEF Foundation provides a reference implementation of the framework specification. It shows the viability of the design by providing a fully functional implementation. The reference

implementation provides a starting point for third parties aiming to commercially exploit all or part of the USEF framework, or aiming to develop products and services built on top of the USEF framework. The reference implementation also serves as a test bed for testing extensions of, or improvements to, the framework's design that are brought forward by the USEF community. The reference implementation has passed conformance testing and is publicly available under the Apache 2 license in the form of downloadable source code on Github: <https://github.com/USEF-Foundation/ri.usef.energy>

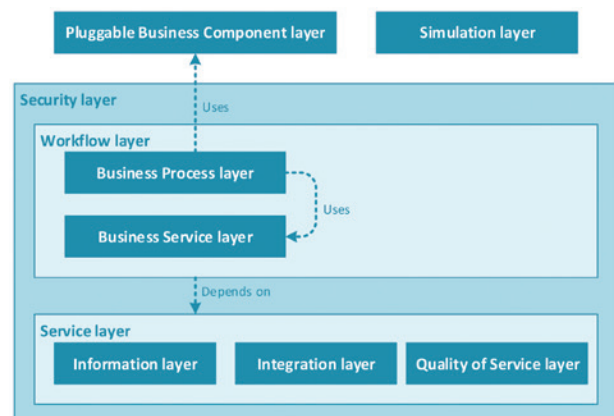

Figure 34: Architecture of the USEF reference implementation.

The reference implementation is accompanied by a set of stub implementations of business logic to demonstrate the USEF framework. These are simple implementations that users of the reference implementation should replace these stubs with implementations that meet their business requirements, either by re-implementing them or by hooking into existing processes.

Being source code, it can easily be transferred, read, modified, and extended to suit the needs of individual customers adopting USEF. By providing the reference implementation for free USEF greatly lowers the costs and implementation time for entering the smart energy market.



4) Main recommendations on Digital roadmap

In this chapter we list our choice of the top 10 recommendations we extracted from the various practical use cases given in the main body of this document. For all the stakeholders in the Digital Transformation these recommendations may shape its own roadmap. Note that the recommendations below are not necessarily ranked.

DON'T MISS THE NON-REVERSIBLE DIGITAL TRANSFORMATION REALITY TODAY

Digitalization for grid operations is ongoing. Currently, the DSO's are investigating which technologies to roll out for a smarter operation of their grid, allowing a higher penetration of distributed generation, a massive integration of storage, smart metering and Network big data at minimum costs and high flexibility.

Currently innovative smart grid management projects are usually performed by larger DSO's... Some smaller DSO's (e.g. more than 800 DSO's exist in Germany) may not be able to adopt these technologies without a clear articulation of the value proposition, time to market, industrialization, shared platforms and accelerated deployment. However, a smart operation of the grid is an important enabler of renewable energy penetration and features such as reactive power injection, curtailment and on-load tap are expected to be cost-efficient now or at least in the near future, depending on the case.

A crucial aspect is that smaller DSO's who do not have the financial resources to perform innovation projects should join the smart grid operation community of practices and join the electronic marketplaces connecting distributors and retailers.

SMART GRID MANAGEMENT IS NOT (YET) A PLUG AND PLAY STORY BUT DIGITAL SMARTGRID IS!

The contributions in this document that discussed digitalization of the grid, either at MV or LV level, put a considerable effort in setting up communication infrastructure and coupling with the data platform. There is not yet an end-to-end solution on the market that provides SCADA and ICT services which are fully interoperable and easy to implement. However, the emergence of the IT/OT integrated or convergent platforms running on Big Data with real time predictive analytics services can play a role in making implementations more efficient.

EMPOWER ICT INFRASTRUCTURES USING DIGITAL SIMULATION MODELS

We observed that increasing monitoring and control at MV level is generally prioritized over LV level, due to the cost of communication and the radial structure of the LV grid, leaving fewer possibilities for smart switching operations. As a DSO, simulation models can be a great tool to identify weak spots in the grid and the most cost-effective way to operate the grid. With the availability of sensor data, a combination with grid analysis tools can effectively increase the vision of the operator on the flows in the grid, reducing the amount of locations where hardware implementations are needed.

OPEN ELECTRONIC MARKET PLACES BOOST DIGITAL ENERGY

In most EU member states that proceed with a smart meter rollout, the DSO is responsible for the collection and the management of the data. In UK, Retailers play an active role in Smart Metering

data collection. DSOs and Retailers should be connected through electronic marketplaces and exchange B2B or B2C digital services (example H2020 project “Flexiciency”). The access to these marketplaces should be open as well to Technology and Energy Service Providers. Data shared like smart metering to third parties should be done in a secured way, compliant with the personal data protection regulation. Local energy markets, improving self-consumption by optimizing multi-commodity energy flows are the next step, already attracting considerable research attention. The DSO’s, Retailers and third Party Technology and Services Providers are recommended to hire big data, Data Scientists and IoT experts for predictive and forecasting analytics, market exchange and will be at the core of these marketplaces.

WELL-GUIDED DATA CONFIDENTIALITY ACCELERATES THE DIGITAL TRANSFORMATION

Traditionally, grid operators have a rather strict policy on data confidentiality with regards to their grid topologies and other grid-related data. However, with the digital transformation and the increased possibilities for smart network control, cooperation with third parties like research institutes in large innovation projects is much more efficient if actual field data can be used. Such well-guided collaboration with third parties has been experienced positively by almost all grid operators involved in innovation projects, accelerating their knowhow and competences at a faster rate.

SMART MANAGEMENT CAN SUCCESSFULLY INTEGRATE MORE RENEWABLES

As one of the contributions to this document is showing, increased forecasting possibilities, in

combination with measures like reactive power control and curtailment are effectively able to increase the hosting capacity of the grid and connecting renewables at an overall lower cost for the society. This requires a regulatory framework to support these new technologies, where DSO’s and producers can work out contracts to connect the generation units to the grid without costly grid upgrades.

LEVERAGING DIGITAL TECHNOLOGIES ENABLES OPEN AND TRANSPARENT FLEX MARKETS

Several initiatives are ongoing to integrate flexibility in the market and create a simple cross-border system for flex trading. However in some European member states industrial flexibility is already integrated in the market, the challenge is to increase the share of flexible demand in the system and develop a transparent market model which can take into account the needs of all actors. This requires leveraging on digital technologies like data handling and IoT in memory and predictive analytics platforms. The relationship between retailers, aggregators and consumers should be studied correctly and the business model for both relationships defined correctly in order to facilitate the market integration of flexible demand while ensuring safe operation of the grid.

AUTOMATED TECHNOLOGIES CAN SHIFT RESIDENTIAL CONSUMPTION

Demand response is already active in several member states in Europe and flexible consumption should be integrated in the market of the remaining countries as soon as possible, by working out appropriate market products. At residential level, smart houses are currently not yet linked to the

energy market. Ongoing initiatives show that flexible household consumption can be shifted in time, when this happens in an automated way. Therefore, when dynamic prices are adopted, an incentive can be provided for consumers to shift their consumption, as well as for technology providers to develop appliance controllers etc.

KEEP INVESTING IN DISRUPTIVE DIGITAL TECHNOLOGIES

Even with the planned reduction of greenhouse gases, global warming is still a problem that presents enormous challenges to the power sector. Large uncertainties still exist towards the generation mix, grid operation and role of the consumer in the energy system in 2050. Therefore, long-term research and investment in so-called ‘disruptive’ technologies is still required.



Conclusions

This report discussed use cases and opportunities of digitalization of the energy system. We conclude the following:

DIGITALIZATION WILL BE HAPPENING

Several use cases are presented and the benefits are discussed. For some use cases, the cost-benefit analysis is not yet positive, however the costs are rapidly decreasing and with increasing distributed generation and introduction of appropriate market models (e.g. including demand response and dynamic pricing), the digitalization of the entire energy system is definitely happening in the coming years.

ACTORS NEED TO ADJUST THEIR STRATEGY

The actors that have been involved in the energy system for many years are challenged to adapt their way of operating and incorporate new technologies that are adopted from other sectors such as the mobile communication sector. In general, the actors in the energy system will have the opportunity to interact much more through dedicated platforms and data exchanges. It is essential that different actors in the energy system, like aggregators, network operators and retailers prepare to adjust their internal operational and business strategy accordingly.

REGULATION PLAYS AN IMPORTANT ROLE

Despite the fact that regulation is not the main focus of this report, it is clear that regulators play an important role providing the correct incentives to develop the required technologies. Examples of this are smart metering functionalities integration of flexible demand and dynamic pricing.

FUNDING RESEARCH AGENCIES WILL BE NECESSARY

Funding agencies are recommended to keep investing in research, as large challenges continue to exist even with the current available technologies and decreasing cost of communication.

In conclusion, in this report we discussed an opportunity, increased connectivity and digital evolution, to tackle a major challenge in sustainable energy i.e. the increased penetration of distributed and intermittent generation. A variety of use cases is being demonstrated in innovation projects. A lot of these demonstrators exploit the increased possibilities for interaction between stakeholders, allowing for a more efficient operation of the system as a whole. The digitalization of the energy system will have a profound impact on all stakeholders and the companies that are prepared for these changes will lead the road to the digital energy system of 2020 and beyond.



APENDIX: ETP SG Workshop on Energy Digitalization

EUROPEAN TECHNOLOGY PLATFORM SMARTGRIDS

Minutes of the Digitalization workshop 24-11-2015 (The physical workshop was reduced to an online workshop due to the situation in Brussels at that time) - all presentations can be found on www.smartgrids.eu.

- 9:30 - 9:40 **Welcome and introduction**
Prof. Nikos Hatziargyriou, HEDNO, ETP SmartGrids Chair
- 9:40 - 10:10 **ETP SmartGrids paper on “Energy digitalisation”**
Maher Chebbo, SAP, ETP Smart Grids, Chairman of WG3 and Digital Energy
- 10:10 - 10:40 **European Commission Digital Smart Grids Strategy**
Patrick van Hove, Rolf Riemenschneider, European Commission
- 10:40 - 11:10 **Break**
- 11:10 - 12:40 **Companies’ presentations on their Energy/SmartGrids Digitalisation Strategy:**
- Aachen University, E.on Research Center, Prof. Antonello Mon
 - EDP, Joaquim Teixeira
 - ENEL, Alessio Montone
 - ESB, Paul Hickey
 - IoT, Tom Raftery
 - SAP, Svend Witttern
 - IT & Energy Innovator, Jean-Luc Dormoy
- 12:40 - 13:30 **Lunch Break**
- 13:30 - 15:00 **General discussion on digitalization**
- 15:45 - 16:00 **Closing Words**
Prof. Nikos Hatziargyriou, HEDNO, ETP SmartGrids Chair
-

ACTIVITIES ETP (NIKOS HATZIARGYRIOU)

ETP for Smart Grids Chairman Nikos Hatziargyriou presents the structure and activities of the ETP and welcomes the participants to the meeting. The meeting is digital due to the situation in Brussels.

INTRODUCTION (MAHER CHEBBO)

Maher Chebbo provides an introduction on ongoing digitalization trends, and the relation to fields as policy, economics, technologies and telecoms and

the demand supply value chain. Estimates are given on the amount of internet users, and new trends such as self-learning. Cyber security is a key issue in a hyper connected world.

New cloud computing techniques can unlock new business cases connected to smart consumers, demand response and smart cities. Forecasting demand is a new service that provides value for several stakeholders. Digitalization is more than IT, it is the combination of IT and business models.

The first draft of the document is still in progress, a draft is suggested by the end of the year, second version beginning of next year, and by February the final draft will be handed over to the commission.

THE DIGITAL ENERGY WORLD (PATRICK VAN HOVE)

Patrick van Hove clarifies the interest of the European Commission into digital smart grids in a historic context. Trends such as the digital home, decarbonisation of generation, ageing grid infrastructure, integration of EV's and liberalization of the market stress the need for increasing digitalization. Variability in the electricity systems enables opportunities for forecasting and automation of industrial and business processes.

The commission is interested to know what the barriers and challenges are, and also what the 'low-hanging fruit' is. The roles of the different actors is the interest of European Commission as well. There is a group within the EC working on digitalization, for which this document will provide important input.

DIGITIZING EUROPEAN INDUSTRY/DIMENSION OF INTERNET OF THINGS (ROLF RIEMENSCHNIEDER)

Rolf Riemenschneider stresses the key interest of Internet of Things for the European Commission. Companies like facebook/apple/google enter other markets. Transition is ongoing from automation to services through online platforms. Google for instance is providing services for mobility, logistics, homes and health. Whoever controls the IOT platforms will rule the future. A key question is which strategy has to be followed by European actors/markets/regulators. In any case we need an ecosystem around the IOT platforms and bring all actors together.

Examples are the Smart city platform in Santander on environment, traffic, irrigation, lighting, and waste management. A combination of services on health, safety, automation, energy efficiency will be needed. Driving cars could generate a large set of data which could be used for several purposes.

One of the objectives is to foster competitiveness hubs of cross-sector industrial platforms. Standardization is a key challenge. An AIOTI WG3 overview of standards is presented. Cross-sectorial approach, supporting implementation of large-scale pilots is followed.

TOWARDS A SERVICE DRIVEN ENERGY MARKET (ANTONELLO MONTI)

Antonello Monti presents the FINESCE project. Seven field tests were conducted, Ireland smart charging, Germany, Belgium, Italy, Denmark, Sweden and Spain. Ericsson was coordinator of the project. He explains how practical use cases are tackled through different layers, from application to data modeling. Different examples of use cases are given with generic and domain specific enabler. FIWARE is a smart city solution using open interfaces, which is essential.

EDP (JOACHIM TEIXEIRA)

New challenges for the DSO and the active consumer. Inovgrid is an EDP smart grid project, which leverages on smart metering and supports a holistic view of the electrical system. More than 30k EDP boxes were rolled out in Evora inovcity. 3.9% of reduction of consumption was achieved. EDP identified a set of development areas to address DSO challenges and start to build a smarter network. Besides metering, also grid supervision and automation capabilities are being developed. Other use cases like assets and messages for consumers in case of outages are important as well.

ENEL (ALESSIO MONTONE)

A world outlook of ENEL is given with an overview of the customers worldwide. The smart network components and architectures are described, including on-load tap changing, LV, MV and HV remote control, voltage regulation and self-healing mechanisms. Components like the ENEL smart meter, smart info, sensors and actuators and electromobility are shown. Of all benefits of digitalization of the grid, the policy is a main driver, and from technological point of view the microgrids are very important.

ESB NETWORKS (PAUL HICKEY)

Connecting customers with distributed generation, active customer participation and future disruptors are a challenge for a DSO like ESB networks.

One specific problem is a new type of pole rot, which is a problem for a million of poles. Accelerated pole rot IT support is necessary. A mobile phone solution that interacts is worked out which can connect with the work force in the field.

A fibre optic network is being rolled out. The Smart meter solution of ESB is shown. Finally, the Realvalue project is explained, where loads are switched on and off.

REDMONK (TOM RAFTERY)

Examples of renewable energy penetration are given like in Denmark, where 140% of the demand was provided by wind energy. The Swanson effect for PV is when the price falls with 20% for every double in capacity. Some existing and disruptive storage technologies are presented. Flexible power alliance network tries to match supply and demand using the Powermatcher software. Some other out-of-the-box examples are added.

SAP (SVEND WITTERN)

A change in energy sources is coming. De-carbonization, de-regulation, de-centralization, digitalization are challenges for the DSO. Super computing, cloud computing, increased connectivity and cyber security are essential for utilities. A digital energy network is envisioned. Energy generation, smart distribution, balancing services and consumption models appear to be changing.

New business models are appearing on wholesale level, flexibility and storage services, sourcing and trading, power transmission/distribution services, market coordination, master point operations, retail and energy related products and services.

IT-ENERGY (JEAN-LUC DORMOY)

Barriers are melting away. Different insights are offered e.g. hire the creatives. Examples of digitalization are given like Uber and self-driving cars. Double sided business models are disruption the old unidirectional business models, as data generated by consumers have an intrinsic value. People management is key as well.

Investments are needed into 'unattainable situations'. Google for instance invests 20% in evolutionary new business and 10% in disruptive new business. Design and market products and services need to come faster. We have to think about opening data.

Discussion: In Liberia a competition looked at geo information on mobile phones and redrew public transport maps. Other example, Mark Zuckerberg asked people to hack into his system.



