



HAL
open science

A System On Chip Dedicated To Pipeline Neighborhood Processing For Mathematical Morphology

Christophe Clienti, Serge Beucher, Michel Bilodeau

► **To cite this version:**

Christophe Clienti, Serge Beucher, Michel Bilodeau. A System On Chip Dedicated To Pipeline Neighborhood Processing For Mathematical Morphology. 16th European Signal Processing Conference (EUSIPCO 2008), Aug 2008, Lausanne, Switzerland. 5 p. hal-00830910

HAL Id: hal-00830910

<https://minesparis-psl.hal.science/hal-00830910v1>

Submitted on 6 Jun 2013

HAL is a multi-disciplinary open access archive for the deposit and dissemination of scientific research documents, whether they are published or not. The documents may come from teaching and research institutions in France or abroad, or from public or private research centers.

L'archive ouverte pluridisciplinaire **HAL**, est destinée au dépôt et à la diffusion de documents scientifiques de niveau recherche, publiés ou non, émanant des établissements d'enseignement et de recherche français ou étrangers, des laboratoires publics ou privés.

A SYSTEM ON CHIP DEDICATED TO PIPELINE NEIGHBORHOOD PROCESSING FOR MATHEMATICAL MORPHOLOGY

Christophe Clienti, Serge Beucher, Michel Bilodeau

Center of Mathematical Morphology, ENSMP
35 Rue Saint Honoré, 77300, Fontainebleau, France
phone: + (33) 1 64 69 47 06, fax: + (33) 1 64 69 47 07, email: christophe.clienti@ensmp.fr
<http://cmm.ensmp.fr>

ABSTRACT

This paper describes a system on chip to compute neighborhood operations for image processing algorithms. The system is based on General Purpose Processor in charge of algorithms scheduling in a deep pipeline named SPoC. The latter is an dedicated architecture to compute neighborhood processing operations thanks to data stream vectorized processors connected each others with a reconfigurable data path. Two applications, a motion detection algorithm and a licence plate extraction are presented to show performances in terms of speed, embeddability and re-usability of the SoC. Comparisons with many architectures such as digital signal processors, workstations or embedded general purpose processors are made to benchmark the platform and prove the originality and the strength of our solution.

1. INTRODUCTION

Since more than 40 years, the use of Mathematical Morphology for image processing is constantly growing in many domains such as medical imaging, computer vision, multimedia application or security [1], [2].

Faced with increasing demand for embedded systems dedicated to efficient image processing, traditional systems are not sufficient to achieve robust real-time applications. Moreover applications are more and more sophisticated and dedicated architectures for image processing are often only specialized in peculiar parts of an application. we can cite many architectures only optimized for some basic operations [3], [4].

Digital signal processors and SIMD processors are not always well suited to very large numbers of calculations required by some sequential stages of an application. Moreover applications require a lot of memory due to increasing resolution of sensor and due to algorithms increasing complexity. Processors can not be fast enough and cache misses may occurs [5]. Wide VLIW or Systolic architecture composed by hundreds of simples processing elements are an alternative to compute algorithm rapidly, however programming model could be often very complicated [6], [7].

Using a neighborhood operators pipeline, where each stage could map an application part, is a possibility to simplify processing and improve performance. In the past, such pipelines were built off-chip with many circuits arranged together to target performance needed [8]. Mathematical Morphology is really well suited to this kind of architecture because it is based on simple operations which can fit into one or more stages of a pipeline. Today we have the opportunity to create reconfigurable architecture with many on-chip

neighborhood operators interfaced with generic purpose processor to schedule processing.

The first part of the paper is dedicated to a short reminder about Mathematical Morphology. In the second part, the platform architecture is presented and emphasis is being placed on vectorized neighborhood processor able to extract multiples sub-window at a time. In the third part, two applications, a video survey motion detection and a licence plate extraction, are described and a benchmark is done between our SoC and different platforms. Finally, the last part is dedicated to improvements and future works.

2. MATHEMATICAL MORPHOLOGY REMINDER

Mathematical Morphology was created in late 60's by G. Matheron and J. Serra. The two morphological basic operations are dilation and erosion, from which, all others operations can be composed.

An Erosion of an function f by a flat structuring element B is defined as follow:

$$[\varepsilon_B(f)](x) = \min_{b \in B} (f(x+b))$$

The dual operator is the dilation:

$$[\delta_B(f)](x) = \max_{b \in B} (f(x+b))$$

A structuring element is a neighborhood window, where for each pixel of the image a set of neighborhood is considered.

Those primitive are considered as basic tools achieving a lot of more complex operations :

- gradient, laplacian
- opening, closing
- geodesic transformations
- distance, quasi-distance
- skeleton (using Hit or Miss operators)
- watershed
- ...

We invite the interested reader to read the Morphological Image Analysis book [2] for an exhaustive introduction to Mathematical Morphology.

The challenge is to build the best optimized architecture to compute rapidly erosion/dilation and to schedule them efficiently.

3. PLATFORM DESCRIPTION

The aim of the designed circuit is to compute Mathematical Morphology algorithms in the framework of embeddable

systems. It is able to acquire images from a source, compute them, and transmit results in real-time constraint evaluated at 30 frames per second. The functional view of the SoC is presented in figure 1.

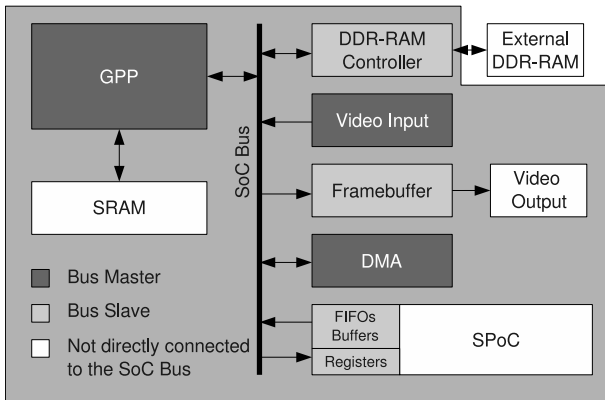

Figure 1: System on Chip for Image Processing With Mathematical Morphology

3.1 Chip structure

The circuit is composed by a simple General Purpose Processor (GPP) which is devoted to control algorithm scheduling and communication in and out of the circuit. If necessary, the GPP can access to image pixels located in the DDR-RAM. This must be sporadic because of important memory latency when cache misses occurs. GPP is a simple 32 bits RISC processor operating at a low frequency and may run an Operating System to manage network communications. Image processing are deported in a dedicated part of the circuit named SPoC (Several neighborhood Processors On Chip). In order to feed the pipeline with pixels through FIFOs, a standard DMA is used to optimize memory transfer from and to the DDR-RAM.

The input video system supports standard video inputs as PAL or NTSC, converted into numerical trams with an external ADC. The video input logic inside the SoC is used to decode frames and to take control of the SoC bus to send pixels directly in DDR-RAM. Optional parts are the framebuffer and the video output which represents a basic graphics system mainly used to display some image processing results.

SPoC is optimized to minimize image memory transfers between each application stage. The pipeline structure allows to process some operations with only one image load/store and it exploits temporal and spatial parallelism to speed up computations. SPoC processing configuration is built with a list of basic operations parameters to be executed such as dilation or erosion, and with a data path parametrization. All those parameters must be stored in configuration registers before starting a process. Border side effects are automatically managed, and only tasks devoted to the GPP are SPoC registers programming and DMA configuration.

Once the pipeline is configured, images pixels are sent to input FIFOs and the process could start. If two images must be sent to the accelerator, the process will start only when pixels will be available in each FIFO. After a latency equal to some lines of an image, depending of the pipeline depth, pixels result are produced and stored in output FIFO at each clock cycle. The GPP must program the DMA to store pixels

progressive results in main SoC memory.

3.2 SPoC structure

SPoC is composed by many neighborhood processors, called PoC, associated in a parallel and in a serial way through a reconfigurable data path and a programmable ALU units, as shown in figure 2. One PoC is able to compute erosion, dilatation, gradient and optionally median filter and convolution with kernel up to 3×3 .

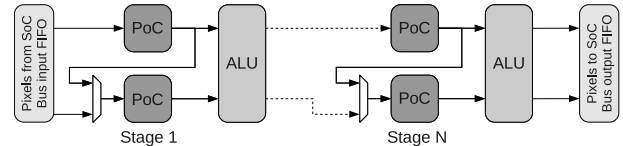

Figure 2: SPoC internal overview

The pipeline structure is really well suited to Mathematical Morphology, and the former is fully used most of the time by each application stages. Moreover SPoC is a MIMD architecture and can process one image in both parallel PoC with the same instruction or process two different images with different operations. Multiplexers in the pipeline allow to use all PoC in the circuit in a serial way. This option is very interesting when we compute alternate sequential filters with big structuring element size.

The ALU unit manages results from parallel PoC, and also reconfigure data paths before a process start. This part is important to compute geodesic operation, distance transformation or any complex transformation. The ALU unit embedded also a Constant Pixel Register (CPR) to compute operations on each pixels with a constant value instead of an image. The figure 3 represents the ALU functional view.

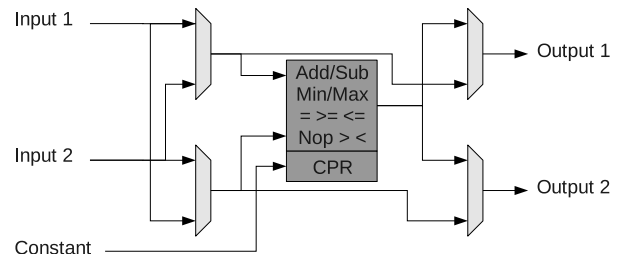

Figure 3: ALU functional overview

The ALU unit allows to compute addition, subtraction, saturated addition, saturated subtraction, absolute value of a subtraction, minimum, maximum on both images input or between an input and CPR. The NOP instruction is decomposed in two NOP instructions in order to choose which input must be directly copied to the output. Compare operations have been introduced to do conditional move or threshold, and many combinations between inputs and CPR are available. For example, we can compare each pixels of two images and replace true values by the CPR when a test is satisfied. We can also test if a pixel is superior to CPR and set the output to the max value authorized by the pixel bus width (0xFF for 8-bit pixels).

PoC implements a parallel neighborhood extractions to speedup computation time as shown in figure 4. At each

clock cycle, PoC extract N successive neighborhoods depending of the pixel vector of size N . The figure 5 shows a simplified view of the neighborhood extraction architecture with a vector of size 4 and a 13×6 image. Register RA1 throw RF2 are neighborhood registers, and at each clock cycle 4 pixels in a little endian order are set to the PoC entry from inputs FIFO. To correctly extracts neighborhoods, PoC operators are composed by 2 delay lines PDL1 and PDL2, figure 4. Those can be reconfigured to match the image width. The size of a delay line is the same than used in standard neighborhood extractor [8], but the geometry must be modified to comply with the pixel vector size.

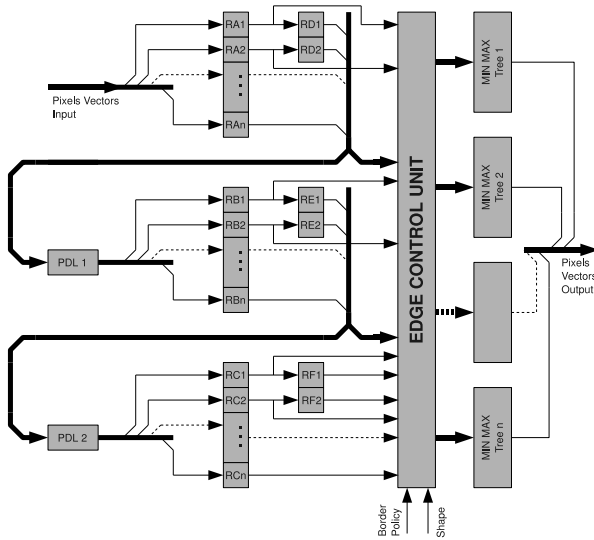

Figure 4: Functional view of PoC

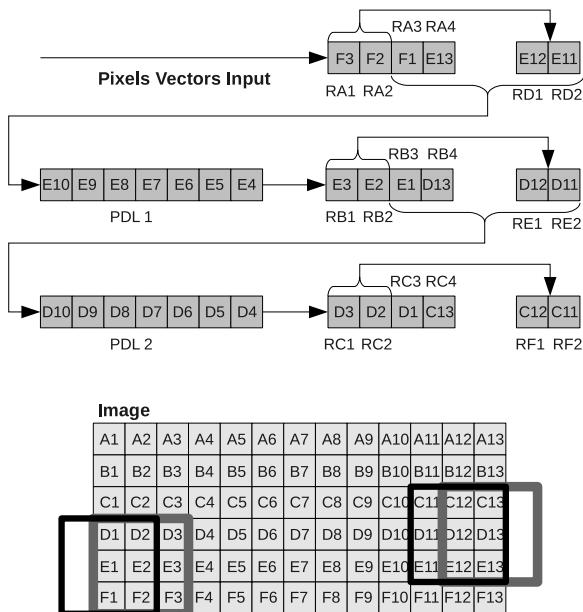

Figure 5: Simplified view of PoC for a vector of 4 pixels

Centers of neighborhoods are represented by registers $\{RB2, \dots, RBn, RE1\}$ and for example, the last

structuring element extracted, considering a raster scan order in the image, is composed by registers $\{RAn, RBn, RCn, RD1, RE1, RF1, RD2, RE2, RF2\}$ where n represent the vector size. Covering between last neighborhood at cycle k and first neighborhood at cycle $k + 1$ is guaranteed by data paths established, for example, between registers $\{RA1, RA2\}$ and $\{RD1, RD2\}$.

Extracted pixels are sent to do Edge Control Unit to set or unset registers regarding neighborhood positions in the image, the structuring element shape and the operation performed: erosion, dilation, median filter or gradients.

The Edge Control Unit is built in three stages. The first stage is a row and column counter, the second one is dedicated to comparators to correctly set or unset pixels in the third stage.

Deselection of registers depends on calculations which must be done with the neighborhood and depends on structuring element used (figure 7). For an erosion, deselected pixels must be replaced by the maximum value authorized by the pixel bus width. For a dilation deselected pixels must be replaced by zero. For the median filter, the policy chosen is to replace value of neighborhood as the image border was filled by a checkerboard. The figure 6 shows the principle and how the sort works.

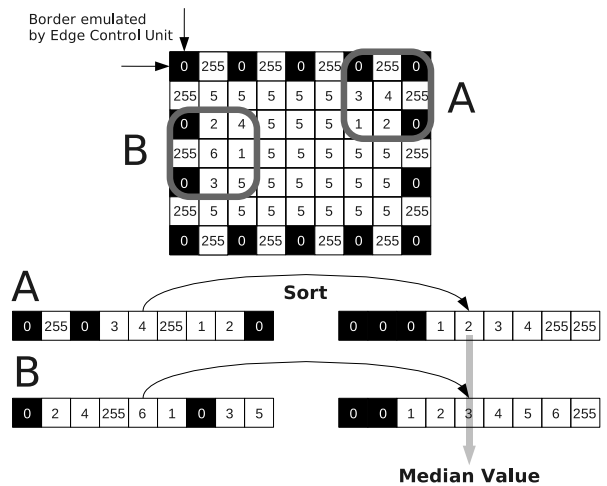

Figure 6: Median Checkerboard

Hence border side are correctly processed, pixels go on throw Min/Max tree. This arithmetic unit is presented in figure 4 and could be replaced before synthesis step by a multiply and accumulate tree to compute convolution or by a bubble sort fully pipeline. With such a sort system, we can process every rank filters (erode, dilate and median are special cases of rank filters). Due to some area constraints we decided to synthesize only the first stage of SPoC with Sort Unit instead of Min/Max tree. It is not necessary to add more stages with bubble sort because the composition rules used for erosion and dilation, which allow us to compose biggest filters, is not valid for others rank filters.

3.3 Programming model

The dedicated architecture could not be addressed directly from video acquisition component because an application could not fit completely into the pipeline and several passes

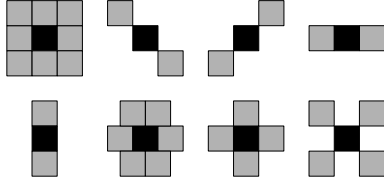

Figure 7: Some possible SE shapes

with the same images must be performed. That is the reason why the pipeline is plugged to the SoC bus to have the opportunity to process several times images in the pipeline. It is able to process multiple pixels at each clock cycle but the general purpose processor in the SoC is not fast enough to feed SPoC with pixels. The processor must just configure DMA to load or store data in FIFO which are written or read by the pipeline. The programming step are shown in figure 8.

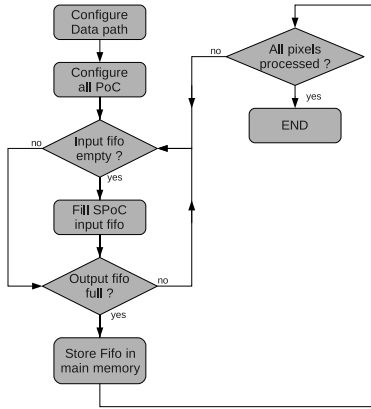

Figure 8: Programming Model

4. APPLICATIONS AND BENCHMARK

The platform presented in this paper aims to run many embedded morphological image processing applications and two examples will be used to benchmark the platform. The first example is a standard video survey motion detection and the second one is an application of licence plate extraction.

The aim in this part is not to build fully robust applications but only benchmark our system against an optimized software implementation with the following architecture:

- Intel Pentium IV running at 3 GHz with 1Mo cache L2 and using SSE instructions
- Trimedia DSP running at 320 MHz
- ARM9 running at 92 MHz

Our SoC is synthesised with a 8-stage SPoC pipeline and running at 100 MHz. The memory allocated, distributed as delay lines in all PoC, is 32 Ko for working with images up to 512 pixels per row. The SoC is routed in a Xilinx FPGA Virtex4 LX 60 and occupy about 21000 slices. SPoC pipeline could be synthesized up to 300 Mhz with Virtex 4 FPGA and up to 400 MHz with Virtex 5.

4.1 Peak computational power

First of all, a benchmark is done to measure, with basic mathematical morphology operations, the peak computational power of our architecture against a Pentium 4, a Trimedia and an ARM. We consider here 512×512 8 bits per pixel images, and benchmark operations are size increasing erosions.

Op. \ Arch.	P4	Trimedia	ARM	Our SoC
erosion 1	0.8	8.2	81	1.3
erosion 3	2.5	24	245	1.3
erosion 10	8.3	82	811	1.3
erosion 17	14	140	1379	2.6

Figure 9: computational time for different erosion of 512×512 images

The figure 9 shows some timing for erosion of size 1 to 17. A size one erosion corresponds to an erosion 3×3 in 8-connexity. The 6-connexity was also used but timing are almost the same. Erosion are iterated multiple times to build bigger structuring elements (composition rule of mathematical morphology). We notice for standard processors that the timing grows at each erosion iteration, while the timing for our SoC grows only when second pass is needed. It is worth mentioning that in a 8-stage SPoC, we can map up to 16 erosions. A seventeenth erosion could not be mapped in the first pass so a second one is mandatory. So, the challenge for an application is to use as much as possible the whole SPoC pipeline.

4.2 Motion Detection Algorithm

The method used to extract motion objects is not based on optical flow estimation and no a priori on the scene is taken into account. The algorithm is fully described in [9] and it is based on spacial morphological gradient over image links. The formula is given hereafter and images result are presented in figure 11.

$$mcm^t = \inf(|g^{t+1} - g^t|, |g^t - g^{t-1}|)$$

The main advantages of this method is to only memorize three successive images to detect motion part of the image. However the camera must be fixed to not disturb the detection. If objects to be detected move to slowly regarding the camera frame rate, gradient can not be calculated using t^{-1}, t, t^{+1} images but t^{-n}, t, t^{+n} sequences. The motion detection algorithm could be calculated easily by storing at each step the gradient.

Images must be also filtered with alternate sequential filters (Asf) before calculating motion detection in order to remove noise due to CMOS sensor.

Op. \ Arch.	P4	Trimedia	ARM	Our SoC
mcm	0.7	3.6	250	1.14
Asf	13.2	121	4103	1.52
Total	13.9	124.6	4353	2.66

Figure 10: Motion detection benchmark (in ms)

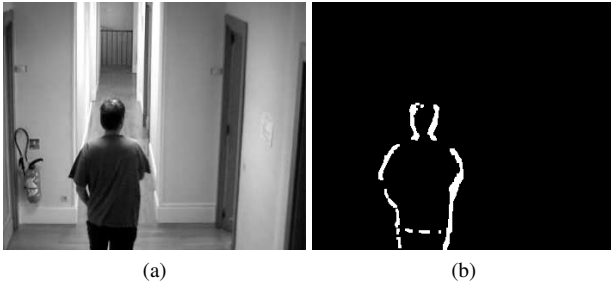

Figure 11: Motion detection Example



Figure 12: Motion detection Example

The figure 10 shows timing results for each application stage with multiple targeted architectures for 320×240 8 bits images. Our SoC performs the application five times faster than a Pentium 4. However “mcm” could not be fully mapped in the pipeline, this implies to do multiple pass, that the reason why timing performance for mcm is weaker than the Pentium 4.

4.3 Licence plate extraction

The method used to extract licence plate is based on adjacency of characters. A similar method is described in [10]. The algorithm is mainly based on tophat transformations with structuring element of size equal to characters width. Moreover post-filtering is needed to remove false positive detection. Equations are given hereafter and image results are presented in figure 12.

$$g(f) = \inf(f - \gamma(f), \phi(f) - f) \quad (1)$$

$$plate(f) = asf(threshold(g(f), a)) \quad (2)$$

Timing performance are similar to those obtained with motion detection application and are given in figure 13.

Arch. \ Op.	P4	Trimedia	ARM	Our SoC
g+plate	11,91	103.99	3435	1.95

Figure 13: Licence plate extraction benchmark (in ms)

In this application the SPoC pipeline is better used and our SoC is six time faster than a Pentium 4 even if the clock frequency is 30 times slower.

5. CONCLUSION AND FUTURE WORK

The SoC described in this paper is an original system which is powerful for neighborhood processing. The system is not

only able to do mathematical morphology but also convolution. The peak computational power of one PoC processor is 3,20 Gops at 100 Mhz, but this could be greatly improved by using 64 bits memory words and a higher frequency. For example with 32 bits word size and a 400 Mhz frequency, the computational power peak for one PoC will be 12 Gops, that will bring a 8-stage SPoC to 204,8 Gops. The most important challenge with SPoC is to use as much as possible the pipeline, but in real application this is not always possible, so our investigation are oriented to the automatic pipeline generation for dynamic partial reconfigurable architecture and automatic software mapping to schedule efficiently applications parts.

REFERENCES

- [1] Dan S. Bloomberg (Editor) John Goutsias (Editor), Luc Vincent (Editor). *Mathematical Morphology and Its Applications to Image and Signal Processing*. Springer, 2000.
- [2] Pierre Soille. *Morphological Image Analysis: Principles and Applications*. Springer-Verlag New York, Inc., Secaucus, NJ, USA, 2003.
- [3] S.H.D. Hulleman, W. Helbert, H. Chanzy, I. Andreadis, A. Gasteratos, and P. Tsalides. An asic for fast grey-scale dilation. *Microprocessors and Microsystems*, 20:89–95(7), April 1996.
- [4] Hugo Hedberg, Fredrik Kristensen, Peter Nilsson, and Viktor wall. A low complexity architecture for binary image erosion and dilation using structuring element decomposition. In *ISCAS (4)*, pages 3431–3434. IEEE, 2005.
- [5] Jaromir Brambor. *Algorithmes de la morphologie mathématique pour les architectures orientées flux*. Thèse de doctorat en morphologie mathématique, ENSMP, 2006. Dirige par Michel Bilodeau.
- [6] S. Kyo, T. Koga, S. Okazaki, and I. Kuroda. A 51.2-gops scalable video recognition processor for intelligent cruise control based on a linear array of 128 four-way vliw processing elements. *Solid-State Circuits, IEEE Journal of*, 38(11):1992 – 2000, Nov. 2003.
- [7] Wolfgang Raab, Nico Bruels, Ulrich Hachmann, Jens Harnisch, Ulrich Ramacher, Christian Sauer, and Axel Techmer. A 100-gops programmable processor for vehicle vision systems. *IEEE Des. Test*, 20(1):8–16, 2003.
- [8] J-C. Klein and R. Peyrard. Pimm1, an image processing asic based on mathematical morphology. In *Second Annual IEEE ASIC Seminar and Exhibit*, pages 7.1.1–7.1.4, Rochester, September 25-28, 1989, 1989. 1263 CF L-32/90/MM.
- [9] L. Biancardini, E. Dokladalova, S. Beucher, and L. Letellier. From moving edges to moving regions. In *IbPRIA 2005, Iberian Conference on Pattern Recognition and Image Analysis*, page 10, Estoril, Portugal, June 7-9 2005, 2005.
- [10] Antonio Albiol, J. Manuel Mossi, Alberto Albiol, and Valery Naranjo. Automatic license plate reading using mathematical morphology. In *Proceedings of the The 4th IASTED International Conference on Visualization, Imaging and Image Processing*, Marbella, Spain, september 2004.