



HAL
open science

General study of single input single output linear time invariant laws. Application to an adapted models algorithm control.

Laurent Praly

► **To cite this version:**

Laurent Praly. General study of single input single output linear time invariant laws. Application to an adapted models algorithm control.. 1980. hal-00705033

HAL Id: hal-00705033

<https://minesparis-psl.hal.science/hal-00705033>

Submitted on 6 Jun 2012

HAL is a multi-disciplinary open access archive for the deposit and dissemination of scientific research documents, whether they are published or not. The documents may come from teaching and research institutions in France or abroad, or from public or private research centers.

L'archive ouverte pluridisciplinaire **HAL**, est destinée au dépôt et à la diffusion de documents scientifiques de niveau recherche, publiés ou non, émanant des établissements d'enseignement et de recherche français ou étrangers, des laboratoires publics ou privés.

General study of single input single output
linear time invariant laws.

Application to an adapted models algorithm control
(AMAC).

Abstract : In this study, we come back on some characteristics of linear time invariant control laws and we show how the single input single output (SISO) adapted model algorithm control (AMAC) is a technique for designing such a law.

June 1980

CAI Ecole des Mines de Paris,
35 Rue Saint Honore, Fontainebleau

A - RETURN ON LINEAR TIME INVARIANT LAWS OF CONTROL

A-1 Introduction

Let us return on what is the problem of sampled-data control systems synthesis.

Given a mathematical model of a process, functional operator between an input and an output, given a set of specifications, given a method to compute a control input, the problem of synthesis may be defined as follows : find the parameters used in the computation of the control input such that the mathematical process with that input meets all the specifications. We spoke about a mathematical model of a process and not about a real physical process. We will say a law of command to be robust if it can be used on a physical process.

More precisely we call robustness the coherence between approximations of a mathematical representation of a physical process, and the sensitivity of performance criteria defined by the specifications, to variations of this representation. Let P_0 be the nominal mathematical process, the control input is designed for, if the performance criteria are continuous in P_0 , we can expect the satisfaction of the specifications for any P in the vicinity of P_0 . Then, the physical process we want to command must have representations each in this vicinity.

Another way to formulate the problem is : the set of mathematical processes, images of the physical process, must be enclosed in the set of mathematical processes which verify the specifications for a given control law.

So we will successively

- define a mathematical process
- define a set of specifications
- define a control law
- find relationships between parameters of the control law
- study the sensitivity of the performance criteria.

A-2 Definitions

A-2.1 Definition of the mathematical model of a process

A-2.1.1 Definition

We define here a discrete time mathematical model of a process as a transformation of a set of sequences called inputs into another set of sequences called outputs.

We differentiate three types of signals between the input sequences :

a controllable measured signal called control and noted e_n

an uncontrollable but measured signal called measured disturbance, and noted v_n

an uncontrollable unmeasured signal called disturbance and noted w_n .

For single input single output systems e, v, w are scalars and so is the output noted s_n .

So, if P is an operator on sequences, we have the relation between inputs and output :

$$s(.) = P(e(.), v(.), w(.)).$$

A-2.1.2 Hypotheses

A-2.1.2.1 Hypothesis on P(H1) :

We suppose P to be a linear time invariant operator which is of rational type and asymptotically stable. Moreover we suppose a non zero static gain.

A-2.1.2.2 Hypothesis on disturbances (H2) :

We suppose both measured and unmeasured disturbances to be causal and to admit z -transforms which verify conditions of final value theorem [1].

If the disturbances are represented as stochastic processes, these hypotheses are made on the mathematical expectations and all the following deterministic results must be considered in mathematical expectation.

Moreover we suppose the output to be linearly time-invariant dependant on the disturbances. So we introduce a new linear, time invariant, asymptotically stable operator Q between the measured disturbance and the output.

A-2.1.3 Representation of the mathematical model of the process

With hypotheses H1, H2, we compute the output $s(n)$, from the inputs $e(n), v(n), w(n)$ by the recursive equation :

$$\sum_{i=0}^{N_f} f_i s_{n-i} = \sum_{i=0}^{N_g} g_i e_{n-i} + \sum_{i=0}^{N_n} h_i v_{n-i} + \sum_{i=0}^{N_f} f_i w_{n-i} \quad (1)$$

where $(f_i)_{i \in (0, \dots, N_f)}$, $(g_i)_{i \in (0, \dots, N_g)}$, $(h_i)_{i \in (0, \dots, N_h)}$ are time invariant scalars.

Neglecting the initial conditions (justified by asymptotic stability), we can represent (1) in a more concise way using z -transforms

$$s(z) = P(z)e(z) + Q(z)v(z) + w(z) \quad (2)$$

where :

$$P(z) = \frac{p_n(z)}{p_d(z)}$$

$$q_d(z) \cdot p_n(z) = \sum_{i=0}^{N_q} g_i z^{N_q - i},$$

$$Q(z) = \frac{q_n(z)}{q_d(z)},$$

$$p_d(z) \cdot q_n(z) = \sum_{i=0}^{N_h} h_i z^{N_h - i},$$

(3)

$$p_d(z) \cdot q_d(z) = \sum_{i=0}^{N_f} f_i z^{N_f - i},$$

and from the causality principle, degree of p_n (resp. q_n) is less than degree of p_d (resp. q_d).

Moreover from the hypotheses, the roots of $p_d(z)$ and $q_d(z)$ are strictly in the unit circle.

So we get the block representation given by figure 1 :

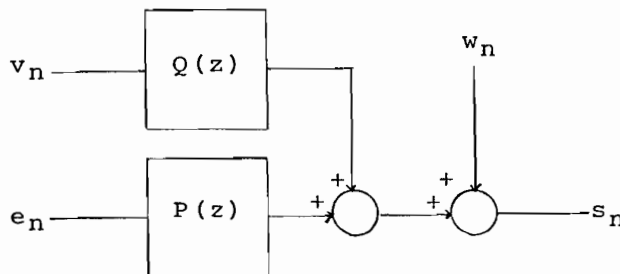

FIGURE 1 - Representation of the process

A-2.2 Definition of a set of specifications

A-2.2.1 Output regulation

We want the effect of non decreasing disturbances on the process to be, in some sense, minimized or eliminated.

A-2.2.2 Output tracking

Given an external non diminishing signal called the set point and noted u_n , we want the output s_n to track u_n with minimal or ideally, zero steady state error. For this problem, we impose a causal set point with z - transform which verifies conditions of the final value theorem.

A-2.2.3 Internal stability

In both cases it is also imperative that an appropriate control law be designed in such a way as to insure an asymptotically stable design i.e. the relations between the external signals (set point, measured and unmeasured inputs) and the internal signals (control, output) must be stable in some sense.

A-2.2.4 Asymptotic convergence

We will summarize the preceding definitions by the asymptotic convergence of the output s_n to the set point u_n

$$\lim_{n \rightarrow \infty} (u_n - s_n) = 0 \quad (4)$$

In fact we have only here the least constraints to set any system of control. The synthesis of such a system must also take into account the behaviour of this convergence and need performance criteria [2]. From greater variability we keep ourselves within the convergence criterion.

A-2.3 Definition of the control law

A-2.3.1 Definition

We call control law a method to compute future controls given the observation of all the measurable past signals. To get a very general linear time-invariant control, we compute a future control e_{n+1} , given the past measured signals $(e_m, s_m, u_m, v_m ; m \leq n)$ as a finite linear combination :

$$e(n+1) = - \sum_{i=0}^{N_a} a_i e_{n-i} - \sum_{i=0}^{N_d} d_i s_{n-i} + \sum_{i=0}^{N_r} r_i u_{n-i} - \sum_{i=0}^{N_b} b_i v_{n-i} \quad (5)$$

Or using z - transforms, we write :

$$c(z)e(z) = r(z)u(z) - d(z)s(z) - b(z)v(z) \quad (6)$$

with $c(z), r(z), d(z), b(z)$ z - polynomials such that degree of $c(z)$ is greater than degree of $r(z), d(z)$ or $b(z)$ and $c(z)$ is mutually prime with $r(z), d(z)$ and $b(z)$.

Note that from the homogeneity of equation (6), there is no use to take rational functions instead of polynomials.

A-2.3.2 Interpretation

Equation (6) has the block diagram representation given in figure 2.

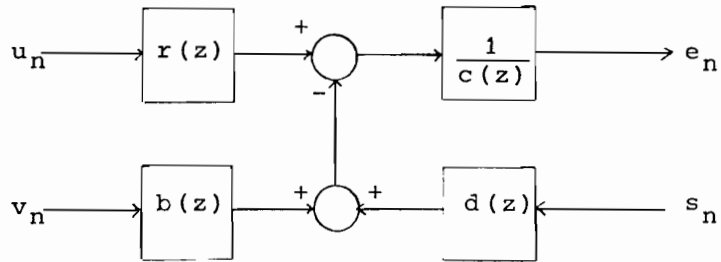

FIGURE 2 - Control law structure

So we can interpret the four parameters c, r, d, b of the control law as [3] :

$c(z)$ is a compensator

$d(z)$ is a sensor

$r(z)$ is a reference

$b(z)$ is a feed-forward input

A-3 Relations between parameters of the control law

A-3.1 Study of the closed loop-system

We study the closed loop-system in its asymptotic behaviour. So we are going to express the various transfers between external and internal signals :

The closed loop system is represented by figure 3

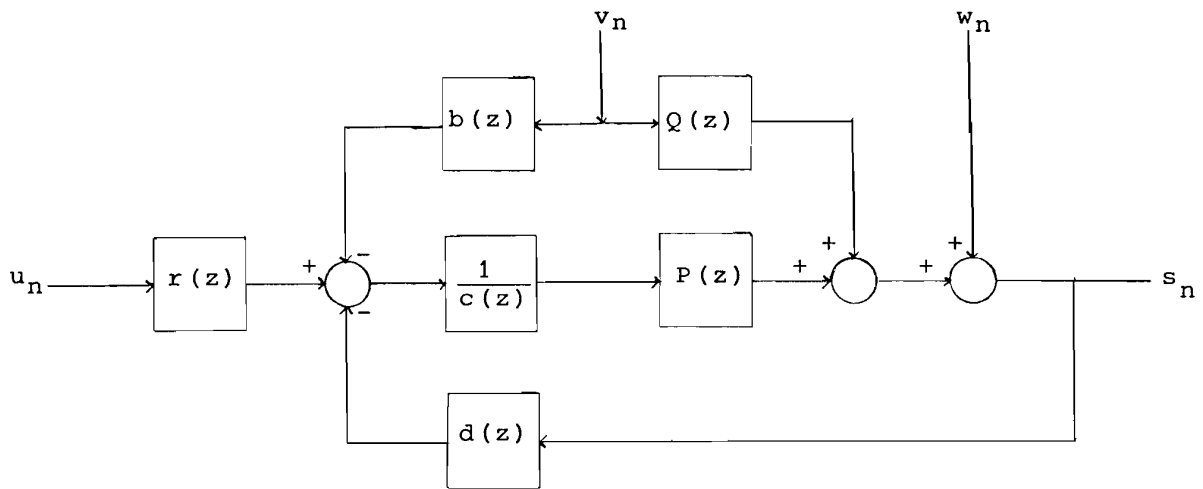

FIGURE 3 - Closed-loop system

We have the z - transform relations :

$$s(z) = S_a(z) u(z) + S_{rv}(z) v(z) + S_{rw}(z) w(z) \quad (7)$$

$$e(z) = E_a(z) u(z) + E_{rv}(z) v(z) + E_{rw}(z) w(z) \quad (8)$$

with : the tracking transfers

$$S_a(z) = \frac{r(z)P(z)}{c(z) + d(z)P(z)} \quad (9)$$

$$E_a(z) = \frac{r(z)}{c(z) + d(z)P(z)} \quad (10)$$

and the regulation feedback and feedforward transfers :

$$S_{r_v}(z) = \frac{c(z)Q(z) - b(z)P(z)}{c(z) + d(z)P(z)} \quad (11)$$

$$S_{r_w}(z) = \frac{c(z)}{c(z) + d(z)P(z)} \quad (12)$$

$$E_{r_v}(z) = -\frac{b(z) + d(z)Q(z)}{c(z) + d(z)P(z)} \quad (13)$$

$$E_{r_w}(z) = -\frac{d(z)}{c(z) + d(z)P(z)} \quad (14)$$

We can see that the poles of any transfer are given by the roots of the expression $c(z) + d(z)P(z)$. Moreover from the stability of $P(z)$, $Q(z)$ and the hypothesis of mutual primeness, a necessary and sufficient condition of internal stability is given by the stability of the control and more precisely by the stability of the $E_a(z)$ transfer.

We shall note that given the stability conditions, the sensor $d(z)$ determine the $E_{r_w}(z)$ regulation transfer, the compensator $c(z)$ determines the $S_{r_w}(z)$ regulation transfer and $r(z)$ determines the $E_a(z)$ tracking transfer. With the error tracking transfer :

$$1 - S_a(z) = S_{r_w}(z) + \frac{(d(z) - r(z))P(z)}{c(z) + d(z)P(z)} \quad (15)$$

we remark that the difference between $d(z)$ and $r(z)$ differentiates between regulation and tracking behaviours.

Whith expression (11), if it is possible to get :

$$c(z)Q(z) = b(z)P(z) \quad (16)$$

we will be able to compensate completely the measured disturbance.

From expressions (9), (11), (12), we can write expression (4) using the final value theorem :

$$\lim_{z \rightarrow 1_+} (1-z) (s(z) - u(z)) = 0 \quad (17)$$

Supposing $s(z), u(z)$ to be defined in the ring $(1, +\infty)$. In order to separate set-point, measured and unmeasured disturbances actions, we will transpose the set of specifications into four constraints :

regulation constraints :

$$S_{r_w}(1) = \frac{c(1)}{c(1) + d(1)P(1)} = 0 \quad (18)$$

$$S_{r_v}(1) = \frac{c(1)Q(1) - b(1)P(1)}{c(1) + d(1)P(1)} = 0 \quad (19)$$

tracking constraint :

$$S_a(1) = 1 = \frac{r(1)P(1)}{c(1) + d(1)P(1)} \quad (20)$$

And stability constraint :

The roots of $c(z) p_d(z) + d(z) p_n(z)$ are strictly in the unit cercle.

A-3.2 Regulation constraints

A-3.2.1 Passive regulation

We want to impose relation (18). With the hypothesis on the process and if the sensor has a non zero static gain, it is necessary and sufficient that :

$$c(1) = 0 \quad (21)$$

So, we must impose a factorization of the compensator in :

$$c(z) = (z-1)m(z) \quad (22)$$

Moreover, from now on, we will write the sensor as $k d(z)$ with :

$$d(1) = 1, \quad k \neq 0 \quad (23)$$

A-3.2.2 Active regulation

From the preceding results, we must impose :

$$b(1) = 0 \quad (24)$$

So, we have the following factorization

$$b(z) = (z-1)n(z) \quad (25).$$

A-3.3 Tracking constraint

We verify expression (20) if we impose identical static gains for both sensor and reference. So as in (23), from now on, we will write the reference as $k r(z)$ with :

$$r(1) = 1, \quad k \neq 0 \quad (26)$$

A-3.4 Remark

With expressions (22), (23), (25) and (26), (6) must be rewritten as

$$zm(z)e(z) = m(z)e(z) + (z-1)n(z)v(z) + k(r(z)u(z) - d(z)s(z)) \quad (27)$$

So the control is computed in a recursive way.

A-3.5 Stability constraint

We study the polynomial :

$$(z-1)m(z)p_d(z)+kd(z)p_n(z)$$

We know already :

- $p_d(z)$ has all its roots strictly in the unit circle
- $k, d(1), p_n(1)$ are different from zero
- degree of $m(z)$ is greater than degree of $d(z)$
- degree of $p_d(z)$ is greater than degree of $p_n(z)$

with no more hypothesis on the process, we can give a sufficient condition of internal stability (Proof in Appendix 1).

If $m(z)$ has all its roots strictly in the unit circle, it exists a vicinity of zero $V(0)$ such that if k is in $V(0)-(0)$, internal asymptotic stability is ensured if and only if :

$$km(1)P(1) > 0 \text{ (stability condition)} \quad (28)$$

with $P(1)$ equal to the static gain of the process.

Note that from continuity, the existence of a vicinity of k can be transposed on the existence of a vicinity of $P(z)$ as we will see in a next section, and so this permits the study of robustness as it was formulated in the introduction.

A-3.6 Introduction of a non linearity on the control

We will extend here the results of Rouhani [4]. We introduce a non linear compensator defined as follows (figure 4).

Let y_n be the input signal of the compensator, we compute the control e_n through the expression :

$$e_{n+1} = f_n \left(\frac{1}{m_0} \left(y_n + \sum_{i=0}^{N-1} (m_i - m_{i+1}) e_{n-i} + m_N e_{n-N} \right) \right) \quad (29)$$

with
$$m(z) = \sum_{i=0}^N m_i z^{N-i}$$

$f_n(x)$ a real time varying function

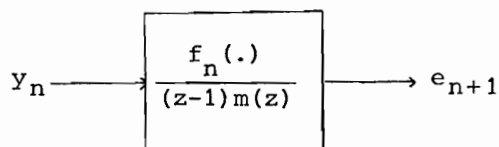

FIGURE 4 - Non linear compensator

To study the behaviour of the closed-loop system, we give an asymptotic value \bar{u} to the set point, we compute a theoretic asymptotic value \bar{e} of the control :

$$P(1)\bar{e} = \bar{u} \quad (30)$$

We suppose the disturbances to be bounded and the processes to be a M.A. system ($P(z) = z^{-N} P_n(z)$).

Then we can say (Proof in Appendix 2) :

Let ρ be the greatest modulus of the roots of $(z-1)^m(z)^{N_p+k}d(z)p_n(z)$, if for any n we have for a certain norm

$$\left\| \begin{array}{c} x_0 \\ \cdot \\ x_{N_p-1} \\ f_n(x_{N_p} + \bar{e}) - \bar{e} \end{array} \right\| < \frac{k}{\rho} * \left\| \begin{array}{c} x_0 \\ \cdot \\ x_{N_p-1} \\ x_{N_p} \end{array} \right\|, \quad k < 1 \quad (31)$$

then the non linear system is stable.

In fact here (with the hypothesis on the disturbances) the stability is taken in the sense of bounded input bounded output (bibo). But if the external signals (set-point, disturbances) become constant, it will become an asymptotic stability and verify relation (4).

A-4 Sensitivity of the convergence criterion

Following our introduction we are going to study the sensitivity of our preceding results to variations of P and Q . In fact given the parameters m, r, k, d, m of the control law, we are looking for the set of P, Q operators for which the convergence criterion is satisfied. To keep the validity of our approach, we will take P, Q in the class of linear time invariant processes.

At once let us remark that only the stability constraint uses hypothesis on P and Q , so we can conclude to insensitivity of the tracking and regulation constraints. And from now on we will look at the stability problem.

A-4.1 Sensitivity to Q

From expressions (9) to (14) it is easy to conclude that for any asymptotically stable Q , we will have internal stability. So, in fact, there is no sensitivity to Q .

A-4.2 Sensitivity to P

In the hypothesis H1 we have imposed P additional constraints to those on Q , particularly rational type and non zero static gain. The latter was essential in regulation and stability constraints. So we must impose variations of P to maintain the sign of the static gain. The former was a theoretic facility but it can be relaxed.

A-4.2.1 P of rational type

In that case we have to find all the pairs of polynomials $(p_n(z), p_d(z))$ such that :

degree of p_d is greater than degree of p_n , and the roots of $p_d(z)$ and $(z-1)m(z)p_d(z)+kp_n(z)d(z)$ are strictly in the unit circle.

Given $p_d(z)$ and the number (N_p+1) of coefficients of $p_n(z)$, suppose $m(z)$ has all its roots in the unit circle, we look for the coefficients p_0, \dots, p_{N_p} such that the polynomial :

$$g(z) = (z-1)m(z)p_d(z) + kd(z) \sum_{i=0}^{N_p} p_i z^{N_p-i} \quad (32)$$

has all its roots in the unit circle.

Let us work in the $g(z)$ coefficients space.

Let \vec{G} be a vector representative of $g(z)$,

\vec{M} be representative of $(z-1)m(z)p_d(z)$,

\vec{P} be representative of $p_n(z)$,

D be a matrix representative of the action of $d(z)$ on $p(z)$.

We have :

$$\vec{G} = \vec{M} + kD \cdot \vec{P}, \quad (33)$$

\vec{G} is linearly dependant on \vec{P} .

Otherwise, given the highest degree coefficient of $m(z)p_d(z)$, from the continuity of the coefficients on the roots, we can say that the set of admissible G s which represent polynomials whose roots are in the unit circle is closed, bounded and connected. Moreover from the presence of $(z-1)$, we can say that \vec{M} is on the frontier of this set. Thus we have the situation given by figure 5.

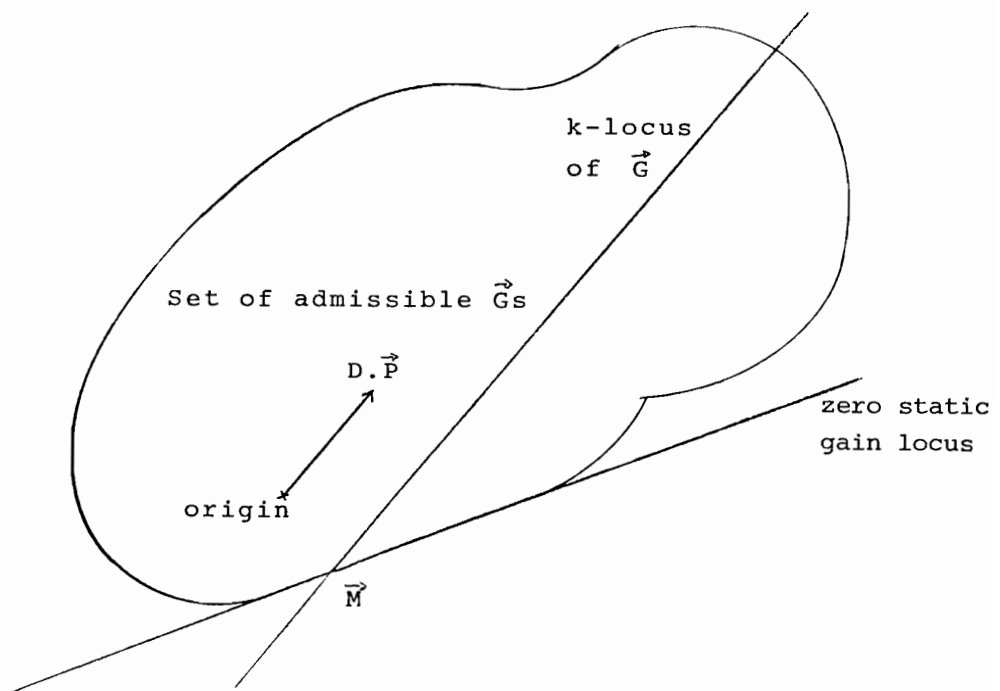

FIGURE 5 - Coefficient representation of stability constraint

So from the knowledge of the set of admissible \vec{G} s, we can find the set of admissible \vec{P} s. The first set has been studied by Markov [6] in the continuous case. Particularly we can't make sure of convexity of the set, so from the linearity we don't know if the set of admissible \vec{P} s is connected.

This approach gives the roles of m , d or k : m corresponds to a translation, d is very similar to a rotation and k to a linear displacement. Moreover we can see the coupling between vicinities of k and P .

A-4.2.2 P in the vicinity of a rational P_0

Suppose the parameters of the control law to be fitted to a nominal process P_0 of rational type. We are looking for variations ΔP around P_0 , such that we have internal stability.

If we suppose $P(z)$ to be an analytic function outside a domain strictly contained in the unit circle and if we note :

$$g(z) = (z-1)m(z) + kd(z)P_0(z) \quad (34)$$

$$h(z) = kd(z)\Delta P(z) \quad (35)$$

Then $g(\frac{1}{z})$ and $h(\frac{1}{z})$ are analytic in and on the unit circle and with the Rouché Theorem [7], we can say that for any process $P(z) = P_0(z) + \Delta P(z)$ such that :

$$|g(e^{i\theta})| > |h(e^{i\theta})| \quad \theta \in [-\pi, \pi] \quad (36)$$

we will have internal stability.

We have in fact here another presentation of the result of Doyle [8] in the SISO case.

A-4.2.3 Application to a polynomial variation

Let us take $\Delta P(z)$ of the form :

$$\Delta P(z) = \sum_{j=0}^N \Delta P_j z^{M-j} \quad (37)$$

Expression (36) means :

$$|(e^{i\theta} - 1)m(e^{i\theta}) + kd(e^{i\theta})P_0(e^{i\theta})| > k|d(e^{i\theta})||\Delta P(e^{i\theta})| \quad (38)$$

$$\forall \theta \in [-\pi, \pi]$$

But we have with appendix 3 :

$$|\Delta P(e^{i\theta})|^2 = \sum_{j,l=0}^N \Delta P_j \Delta P_l \cos(j-l)\theta \quad (39)$$

$$|\Delta P(e^{i\theta})|^2 < \left(\sum_{j=0}^N \Delta P_j^2 \left(\frac{N+1}{2} + \frac{1}{2} \right) \left| \frac{\sin(N+1)\theta}{\sin\theta} \right| \right) \quad (40)$$

So we can get an upper bound of the modulus :

$$\left(\sum_{j=0}^M \Delta P_j^2 \right)^{\frac{1}{2}} < \min_{\theta \in [-\pi, +\pi]} \frac{|(e^{i\theta}-1)m(e^{i\theta}) + kd(e^{i\theta})P_0(e^{i\theta})|}{k |d(e^{i\theta})| \cdot \left(\frac{N+1}{2} + \frac{1}{2} \right) \left| \frac{\sin(N+1)\theta}{\sin\theta} \right|} \quad (41)$$

Practically an FFT algorithm will provide all these spectra.

A-4.2.4 Convergence criterion sensitivity index (CCI)

Given a process P_0 and the parameters of the control law we define an absolute index by :

$$CCI(P_0, m, k, d) = \min_{\theta \in [-\pi, +\pi]} \left| \frac{(e^{i\theta}-1)m(e^{i\theta})}{k d(e^{i\theta})} + P_0(e^{i\theta}) \right| \quad (42)$$

From expression (36) this index gives an upper bound on the possible spectrum variation to verify convergence criterion. So we call it a convergence criterion sensitivity index. To insure robustness, it has to be compared with an equivalent approximation index given by the P_0 model estimation phase.

A-5 Summary

In this first part, we came back on the problem of linear control. The most important results have been reformulated in a very general way : results on the structure of the control law, results on stability in the linear case and in a simple non linear case and at last results on a measure of the sensitivity of stability.

B. THE SINGLE INPUT-SINGLE OUTPUT (SISO)
ADAPTED MODEL ALGORITHM CONTROL (AMAC)

We have just presented a linear time invariant control law in a general fashion. It is an abstract approach which serves only to ensure the convergence criterion. In an attempt to get behavior criteria, we are going to give a physical presentation through a SISO control based on the mathematical representation of the process of paragraph A-2.1.3:

$$s(z) = P(z)e(z) + Q(z)v(z) + w(z) \quad (1)$$

and the use of adapted models of the operators P,Q.

B-1. General SISO AMAC Presentation

B-1.1 Definition of the Strategy

At time n, given the past measurable signals, the SISO AMAC computes a control such that a predicted output of the process is identical to a predicted set point.

Taking the notation of Box and Jenkins [9], we write this:

$$s_n(1) = u_n(1) \quad (2)$$

the prediction being here of one point ahead. From the representation of the process (1) we decompose the predicted output into two parts: a deterministic part which functionally depends on the inputs and a non-deterministic part $su_n(1)$ resulting from the disturbances. Let $M(e_n(1), e_\ell; \ell \leq n)$ be a model of the operator P which defines the deterministic

output from the future and past controls, we deduce from (2) the control law as:

$$M(e_n(1), e_\ell; \ell \leq n) = u_n(1) - su_n(1) \quad (3)$$

Then to compute the control $e_n(1)$ we have three different problems: inversion of M , estimation and prediction of the non-deterministic output, and prediction of the set point.

B-1.2 Inversion of the Model M

From its definition, M is a model of the process. Note that to compute $e_n(1)$, we use this model in a reversed way compared to the physical transfer, so we require M to be invertible in the sense defined by Box and Jenkins [9] and we call it a deconvolution model. Thus with the linear time invariant hypothesis the model of the process is taken linear, time invariant, asymptotically stable, of rational type and invertible.

Let md_i or $Md(z)$ be the impulse response and the rational z -transform of this deconvolution model. We obtain from (3)

$$md_0 \cdot e_n(1) = - \sum_{i=1}^{\infty} md_i \cdot e_{n+1-i} + u_n(1) - su_n(1) \quad (4)$$

and md_0 must be different from zero.

B-1.3 Estimation and Prediction of the Non-Deterministic Output

From expression (1) the non-deterministic output is the sum of both a filtered measured disturbance v_n and an unmeasured disturbance w_n . Suppose we have an estimation \hat{w}_n of w_n and a convolution model of the

measured disturbance filter $Q : nc_i(Nc(z))$, then if $v_n(1)$ and $\hat{w}_n(1)$ are predictions of measured and unmeasured disturbances, we compute:

$$su_n(1) = nc_0 v_n(1) + \sum_{i=1}^{\infty} nc_i v_{n+1-i} + \hat{w}_n(1) \quad (5)$$

So we first need the estimation $w_n(1)$ of the unmeasured disturbance and secondly measured and unmeasured disturbance predictors.

We already introduced a convolution model Nc of Q . Let us take also a new model $mc_i(Mc(z))$ of the process P . This time we need a model to be used in the same way as the process so $Mc(z)$ is a convolution model compared with $Md(z)$, a deconvolution model. Similarly to expression (1), we compute the estimation \hat{w}_n by

$$\hat{w}_n = s_n - \sum_{i=0}^{\infty} mc_i e_{n-i} - \sum_{i=0}^{\infty} nc_i v_{n-i}$$

Now from the past v_n and \hat{w}_n , we want to predict $su_n(1)$. From discrete parameter prediction theory [10], $v_n(1)$ and $\hat{w}_n(1)$ can be computed with prediction filters. Using z -transforms they may be expressed as

$$\begin{aligned} \hat{w}_n(1)(z) &= F_w(z) \hat{w}(z) = \frac{fwn(z)}{fwd(z)} \hat{w}(z) \\ v(1)(z) &= F_v(z) v(z) = \frac{fvn(z)}{fvd(z)} v(z) \end{aligned} \quad (7)$$

where $fwn(z)$, $fwd(z)$, $fvn(z)$, $fvd(z)$ are polynomials in z , the degree of fwd (resp fvd) being greater than the degree of fwn (resp fvn). Moreover, to be able to predict the continuous component of the disturbances, we

impose unit static gain predictors.

Thus we get the z-transform of $su_n(1)$:

$$su(1)(z) = N_c(z) v(z) + F_w(z) \hat{w}(z) \quad (8)$$

with $N_c'(z)$ (nc_i') computed from N_c and F_w through the relation:

$$nc_0 v_n(1) + \sum_{i=1}^{\infty} nc_i v_{n+1-i} = \sum_{i=0}^{\infty} nc_i' v_{n-i} \quad (9)$$

Now from z-transform of (6) we have the final relation:

$$su(1)(z) = F_w(z)(s(z) - Mc(z)e(z)) + (N_c'(z) - F_w(z)N_c(z))v(z) \quad (10)$$

or equivalently in the time domain:

$$su_n(1) = fw_i * (s_i - mc_i * e_i) + (nc_i' - fw_i * nc_i) * v_i \quad (11)$$

where * represents the discrete convolution operator.

B-1.3 Set Point Prediction

To get a better behavior of the closed-loop system, at time n we need future set points. In some cases they are available (particularly when there is a hierarchical control). But generally we need a predictor. Let us take it in the form of a rational filter $Fu(z)$ with fu_i as impulse response and with unit static gain.

$$\hat{u}(1)(z) = Fu(z)u(z) = \frac{fun(z)}{fud(z)} u(z) \quad (12)$$

or

$$\hat{u}_n(1) = fu_i * u_i \quad (13)$$

with $fun(z)$, $fud(z)$ polynomials in z , with the degree of $fud(z)$ greater than or equal to the degree of $fun(z)$.

B-1.4 Expression and Properties of the SISO AMAC Law

From expressions (3), (11) and (13) we get the SISO AMAC law

$$e_n(1) = \frac{1}{md_0} [(fw_i * mc_i - md_i) * e_i + fu_i * u_i - fw_i * s_i - (nc_i' - fw_i * nc_i) * v_i] \quad (14)$$

This prediction is used as the future control e_{n+1} . Thus we get the z -transform representation of the SISO AMAC law:

$$\begin{aligned} (z * Md(z) - Fw(z) * Mc(z))e(z) &= Fu(z) * u(z) - Fw(z)s(z) \\ &- (Nc'(z) - Fw(z)Nc(z))v(z) \end{aligned} \quad (15)$$

Then we find the expression of the four polynomials of our general linear time invariant control law:

$$\begin{aligned} c(z) &= z * Md(z) - Fw(z)Mc(z) \\ r(z) &= Fu(z) \\ d(z) &= Fw(z) \\ b(z) &= Nc'(z) - Fw(z)Nc(z) \end{aligned} \quad (16)$$

Thus we can give a physical interpretation to these polynomials. Moreover, we see that from a physical point of view c , r , d and b are not mutually independent, but Md or Mc , Nc , Fu , Fv and Fw are.

The regulation and tracking constraints (see Part A) are verified since we have imposed:

$$\begin{aligned} Md(1) &= Mc(1) \\ Fu(1) &= Fv(1) = Fw(1) = 1 \\ Nc'(1) &= Nc(1) \end{aligned} \quad (17)$$

The stability constraint (Appendix 4) can be verified by a modification of the dynamic of the unmeasured disturbance predictor if: the different models and predictors are stable, the numerator of the deconvolution model has all its roots strictly in the unit circle, the following inequality is satisfied: $Md(1) \cdot P(1) > 0$. (18)

Now assuming a perfect knowledge of the process and the measured disturbance filter:

$$Mc(z) = P(z); Nc(z) = Q(z) \quad (19)$$

we can write the expected closed-loop tracking and regulation transfer:

$$S_a(z) = \frac{Fu(z)P(z)}{z Md(z)} \quad (20)$$

$$S_{rw}(z) = 1 - \frac{Fw(z)Mc(z)}{z Md(z)} \quad (21)$$

$$S_{rv}(z) = Q(z) - \frac{Nc'(z)Mc(z)}{z Md(z)} \quad (22)$$

So the closed-loop tracking transfer is the product of the set point predictor and the deconvolution model mismatch of the process. Similarly we get the closed-loop regulation transfer. Thus in a perfect matching, the various predictors specify the tracking and regulation closed-loop transfers.

The block representation of the SISO AMAC is given by Figure 6.

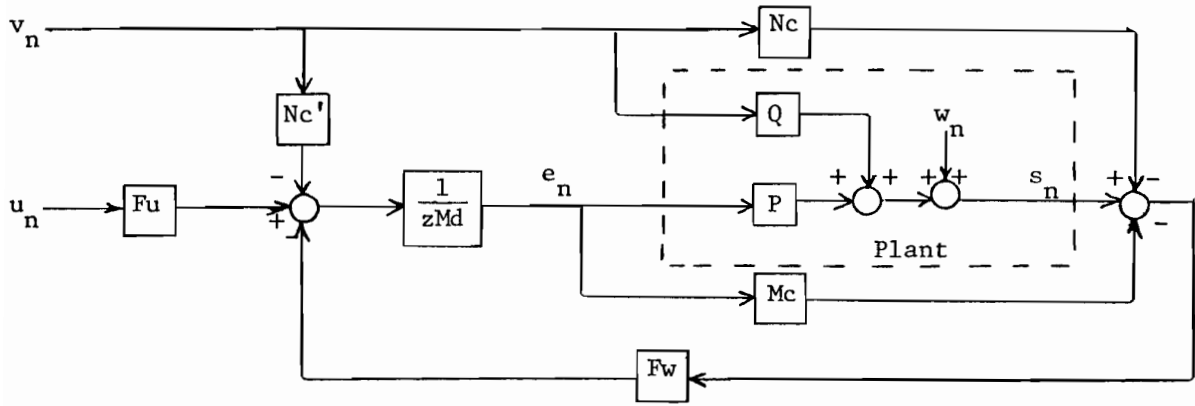

Figure 6. SISO AMAC Representation

M_c convolution model of the process

M_d deconvolution model of the process

P deterministic part of the plant

Q stochastic part of the plant (disturbance process)

N_c convolution model of the disturbance process

N_c' predictive convolution model of the disturbance process

F_u set point predictor

F_w unmeasured disturbances (w_n) predictor

B-2. SISO AMAC Examples

Following our presentation we will present two classical control systems used whenever the convolution and deconvolution model can be identical.

B-2.1 The Optimum Control System of Phillipson [11]

Let us suppose no measured disturbance and an asymptotically stable process with a delay of ℓ samples. We take a convolution model with a delay of k samples, k underestimation of ℓ :

$$M_c(z) = z^k M_d(z) \quad (23)$$

with $M_d(z)$ supposed to have all its roots strictly in the unit circle. Then if we take a unit gain element as a set point predictor, and a k -step-predictor $z^k H(z)$ for the disturbance, we obtain the optimal control system of Phillipson (Figure 7) which is an improvement over the Smith controller.

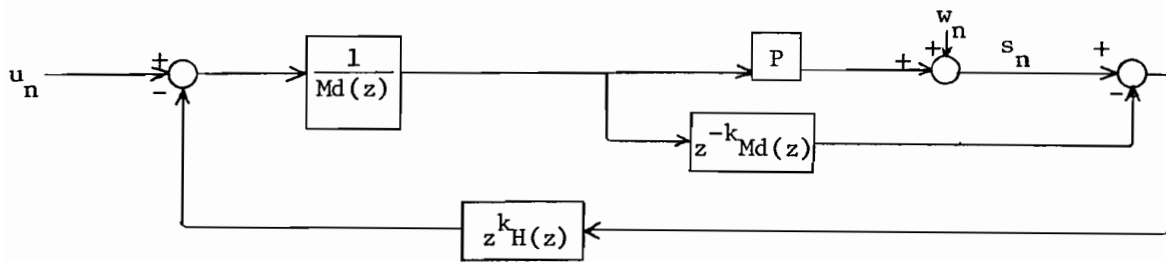

Figure 7. Optimum Control System of Phillipson

As mentioned by Phillipson, this system used in regulation is equivalent to the Box-Jenkins-Astrom minimum-variance control [9] or to the Kalman linear regulator [12].

Thus, this system is essentially made for regulation. Moreover, the use of the inverse model as controller since this will be a high-pass filter, amplifies noise, causes violent changes in the control signal and perhaps frequent saturation. That is why the AMAC uses here an adapted model and

avoids rapid changes in set point thanks to the set point predictor. Predictor H can be easily computed when the disturbance can be described as the output of a known rational filter whose input is an independent zero-mean random sequence. But to verify internal stability we must not forget the constraints on the denominator of H. Here Phillipson suggests the use of exponential smoothing for prediction to solve the problem. That way, we can answer satisfactorily the output regulation but not so properly the output tracking. The model predictive heuristic control which follows attempts to answer the two questions introducing a set point predictor and deducing the disturbance predictor.

B-2.2 Model Predictive Heuristic Control (MPHC) [13]

We give here a simplified study of this method; the very general study can be found in [14]. Suppose no measured disturbance (MPHC can be extended to this case) and a convolution model having a moving average (MA) structure with all its roots strictly in the unit circle, we take:

$$M(z) = M_c(z) = M_d(z) \quad (24)$$

For the set point and disturbance predictors, we choose

$$F_u(z) = \frac{1 - G(1)}{1 - z^{-1}G(z)} \quad (25)$$

$$F_w(z) = \frac{1 - G(z)}{1 - z^{-1}G(z)}$$

where $G(z)$ is a nonzero static gain transfer such that $F_u(z)$ and $F_w(z)$ satisfy stability conditions.

Then from (15) we get the MPHC law:

$$\left(z - \frac{1-G(z)}{1-z^{-1}G(z)}\right) \cdot M(z) \cdot e(z) = \frac{1}{1-z^{-1}G(z)} [(1-G(1))u(z) - (1-G(z))s(z)] \quad (25)$$

$$(z-1) \cdot M(z) \cdot e(z) + s(z) = (1-G(1))u(z) + G(z)s(z) \quad (26)$$

Let us develop the strategy of this relation.

Both terms are similar to outputs. We call the left-hand term a predicted output $s_p(z)$ and the right-hand term a reference output $s_R(z)$.

From

$$s_p(z) = zM(z)e(z) + (s(z) - M(z)e(z)) \quad (27)$$

we define the predicted output as the output of the model at time $(n+1)$ corrected of the estimation $\hat{w}(n)$ of the disturbance

$$s_p(n+1) = s_M(n+1) + \hat{w}(n) \quad (28)$$

with $s_M(n+1)$ output of the model with a predicted input $e_n(1)$. The reference output $s_R(z)$ is given by a trajectory connecting the past outputs of the process to the present set point.

$$s_R(n+1) = \left(1 - \sum_{i=0}^{\infty} g_i\right) u_n + \sum_{i=0}^{\infty} g_i s_{n-i} \quad (29)$$

Thus the MPHC strategy consists in computing future inputs such that predicted outputs are on a connecting trajectory. Its block representation is given by Figure 8.

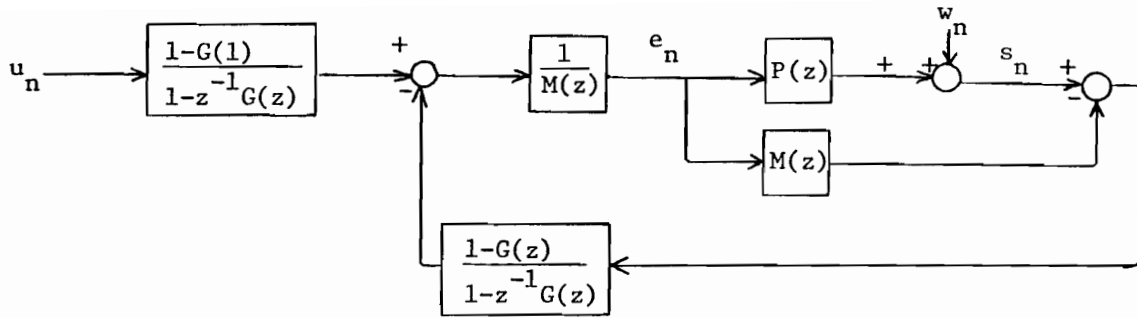

Figure 8. MPHC Representation with $G(z)$ as Connecting Trajectory Generator

From part A, we will satisfy the convergence criterion if $M(z)$ has all its roots strictly in the unit circle and $(1-G(1))$ is taken as the stability coefficient. But again, the transfers are not independent, for instance in a perfect modeling we have:

$$S_a(z) = \frac{1-G(1)}{z-G(z)} \quad (30)$$

$$S_{rw}(z) = 1 - \frac{1-G(z)}{z-G(z)} = \frac{z-1}{z-G(z)} = \frac{z-1}{1-G(1)} S_a(z) \quad (31)$$

The regulation transfer is the discrete differentiation of the tracking transfer. Moreover, if the model does not verify the stability condition, the strategy must be seriously questioned but it has been extended to this case by the introduction of the notion of adapted model [14].

B-3. Choice of the Deconvolution Model

We have seen that the most general linear time invariant control law contains five independent physical components. Theoretically each can be obtained from a modeling (system or spectrum). But the deconvolution model is a special case because its use is not a physical one. We are

going to show where the problem is and how to solve it.

B-3.1 Terms of the Problem and Mathematical Solution

Let $Md(z)$ be this deconvolution model

$$Md(z) = \frac{mdn(z)}{mdd(z)} \quad (32)$$

with $mdn(z)$, $mdd(z)$ polynomials in z such that with expectation (4) degree of $mdd(z)$ is equal to degree of $mdn(z)$.

$Mc(z)$ is the knowledge of the process, i.e., the convolution model:

$$Mc(z) = \frac{mcn(z)}{mcd(z)} \quad (33)$$

with $mcn(z)$, $mcd(z)$ polynomials in z , with degree of $mcd(z)$ greater than degree of $mcn(z)$. The differences between these models are in their use. Let e, s be the input and the output, we write

$$s(z) = \frac{mcn(z)}{mcd(z)} e(z) \quad (34)$$

similarly to the process, but:

$$e(z) = \frac{mdd(z)}{mdn(z)} s(z) \quad (35)$$

is a reversed relation compared with the process.

As we want a stationary control law, following Box and Jenkins [9], we have to improve the stability of both transfers $\frac{mcn(z)}{mcd(z)}$ and $\frac{mdd(z)}{mdn(z)}$. The former can be ensured from the stability of the process. But the

latter has no physical significance and we have seen that we must impose $mcn(z)$ to have all its roots strictly in the unit circle.

As $mdd(z)$ has no constraint in the deconvolution use, we can take:

$$md(z) = mdd(z) = mcd(z) \quad (36)$$

Moreover, to get a zero static gain compensator, with expression (16), we must impose:

$$mdn(1) = mcn(1) \quad (37)$$

Thus the problem is: knowing the model of the process $mcn(z)$, how to choose $mdn(z)$ such that it keeps the significance of a model and it satisfies the stability condition.

If $mcn(z)$ has all its roots strictly in the unit circle, we take obviously:

$$mdn(z) = mcn(z) \quad (38)$$

So the real problem occurs when $mcn(z)$ has roots on both sides of the unit circle. Let us factorize $mcn(z)$ into:

$$mcn(z) = min(z) \cdot mon(z) \quad (39)$$

where $min(z)$ has all its roots strictly inside the unit circle, $mon(z)$ has all its roots strictly outside the unit circle. We don't deal with unit modulus roots. As $mdn(z)$ is used as a denominator, let us consider:

$$mid(z) = \frac{md(z)}{min(z)} \quad (40)$$

$$\text{mod}(z) = \frac{1}{\text{mon}(z)} \quad (40)$$

$\text{mid}(z)$ is a holomorphic function defined outside a domain strictly contained in the unit circle, so its Laurent expansion in the vicinity of the unit circle is:

$$\text{mid}(z) = \sum_{j=0}^{\infty} \text{mid}_j z^{-j} \quad (41)$$

$\text{mid}(z)$ corresponds to a causal impulse response and so has a physical significance.

Inversely, $\text{mod}(z)$ is a holomorphic function defined in a domain strictly containing the unit circle, so its Laurent expansion in the vicinity of the unit circle is

$$\text{mod}(z) = \sum_{j=0}^{\infty} \text{mod}_j z^j \quad (42)$$

Thus, $\text{mod}(z)$ can be considered as corresponding to a noncausal impulse response. And so expression (35) or (3) implies the knowledge of the future outputs: $e_n(1)$ is functionally dependent on $u_n(k)$, $su_n(k)$, $k \in \mathbb{N}$. Precisely, from (3) we get:

$$z \frac{\text{min}(z)}{\text{md}(z)} e(z) = \text{mod}(z) [u(1)(z) - su(1)(z)] \quad (43)$$

$e_n(1)$ depends on the term

$$\sum_{j=0}^{\infty} \text{mod}_j (u_n(j) - su_n(j)) \quad (44)$$

i.e., for the one step ahead prediction input, we need j -step predictions of the set point and the non-deterministic output for all positive integers j . This is a mathematical result; the physical problem is that predictions are not real values. Thus the strategy of the SISO AMAC cannot be totally ensured.

We are going to show how this mathematical solution can be used to design the control law.

To simplify the statement, we will suppose no measured disturbance and as suggested by Phillipson and MPHC applications, we take exponential smoothing for prediction:

$$\begin{aligned} F_u(z) &= \frac{1-t}{1-tz^{-1}} \\ F_w(z) &= \frac{1-r}{1-rz^{-1}} \end{aligned} \quad (45)$$

with t, r called tracking or regulation coefficients. Moreover, as there is no problem on the model's denominator, we suppose an MA model (with p the number of coefficients)

$$Mc(z) = \frac{mc(z)}{z^p} \quad (46)$$

with $mc(z)$ factorized in $mi(z) \cdot mo(z)$.

So we will work with the block representation given by Figure 9 and the AMAC law given by the relations

$$md_0 e_n(1) = - \sum_i md_i e_{n+1-i} + u_n(1) - su_n(1) \quad (47)$$

$$\begin{aligned}
 u_n(j) - u_n(1) &= t u_{n-1}(1) + (1-r)u_n; \quad u_0(1) = u_0 \\
 su_n(j) &= su_n(1) = t su_{n-1}(1) + (1-r)\hat{w}_n; \quad s_0(1) = \hat{w}_0 \\
 \hat{w}_n &= s_n - \sum_i mc_i \cdot e_{n-i}
 \end{aligned}
 \tag{47}$$

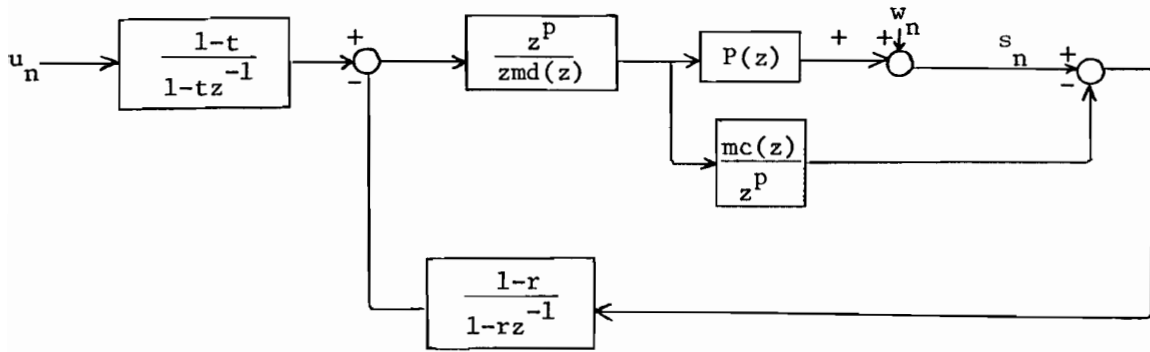

Figure 9. AMAC Representation for Study

B-3.2 Direct Application of the Mathematical Solution

From the factorization of $mc(z)$, let mi_j be the impulse response corresponding to the roots inside the circle and mod_j be the noncausal impulse response corresponding to the inverse of the factor containing the roots outside the unit circle. We write the control law as:

$$\min_0 e_n(1) = - \sum_j mi_j e_{n+1-j} + \sum_j mod_j (u_n(j) - su_n(j))
 \tag{48}$$

But with our constant prediction we have:

$$\min_0 e_n(1) = - \sum_j mi_j e_{n+1-j} + \left(\sum_j mod_j \right) (u_n(1) - su_n(1))
 \tag{49}$$

With exponential smoothing for predictions the mathematical solution gives a deconvolution model which has among the roots of the convolution model

only those which are strictly in the unit circle.

From (20), (21)

$$S_a(z) = \frac{1-t}{z-t} \frac{\text{mon}(z)}{z^0 \text{mon}(1)}$$

$$S_{rw} = 1 - \frac{1-r}{z-r} \frac{\text{mon}(z)}{z^0 \text{mon}(1)}$$
(51)

With 0 the number of roots of $\text{mon}(z)$. Thus, the prescribed behaviors can be followed only after the response time of $\text{mon}(z)$.

B-3.3 k-Step Prediction

Our mathematical presentation tells us that to compute $e_n(1)$ we need further predictions. So one idea is to rewrite the AMAC strategy as

$$s_n(k) = u_n(k)$$
(52)

with no a priori distinction between the models.

Then (47) gives

$$\sum_{i=0}^{k-1} mc_i e_n(k-i) = - \sum_{i=k}^p mc_i e_{n+k-i} + u_n(1) - su_n(1)$$
(53)

Thus the control $e_n(1)$ depends on the predicted inputs $e_n(j)$ and we have to solve a linear system with k unknown quantities. To get a unique solution one could introduce a criterion on the predicted inputs.

Let us look for a solution linearly dependent on the right term as:

$$\begin{pmatrix} e_n(k) \\ \vdots \\ e_n(1) \end{pmatrix} = \begin{pmatrix} f_k^{-1} \\ \vdots \\ f_1^{-1} \end{pmatrix} \left(- \sum_{i=k}^p mc_i e_{n+k-i} + u_n(1) - su_n(1) \right)$$
(54)

$e_n(1)$ is the single quantity of interest and we have the control law:

$$f_1 e_n(1) = - \sum_{i=k}^p mc_i \cdot e_{n+k-i} + u_n(1) - s u_n(1) \quad (55)$$

Thus the implicit deconvolution model is:

$$Md(z) = f_1 + \sum_{i=0}^{p-k} mc_{i+k} z^{-(i+1)} \quad (56)$$

but with the static gain relation, we need:

$$f_1 + \sum_{i=0}^{p-k} mc_{i+k} = \sum_{i=0}^p mc_i \quad (57)$$

and necessarily,

$$f_1 = \sum_{i=0}^{k-1} mc_i \quad (58)$$

The indetermination of expression (53) is illusive. This k step prediction strategy gives the MA deconvolution model:

$$Md(z) = \sum_{i=0}^{k-1} mc_i + z^{-1} \sum_{i=k}^p mc_i z^{k-i} \quad (59)$$

Then the problem is how to choose the integer k in such a way as $Md(z)$ has all its roots strictly in the unit circle. Obviously there is at least the solution $k=p$, but then the prescribed behavior can be followed only after the time response of the process. This solution is not interesting

but the deconvolution model can be easily computed.

This k-step prediction strategy can be extended. Given a set I of positive integers, we impose:

$$s_n(k) = u_n(k), \forall k \in I \quad (60)$$

This leads as previously to a linear system whose unknown quantities are the predicted inputs. It can be solved in various ways, but the solution must give a deconvolution model satisfying the stability conditions [14].

The advantage of such an approach is in the constrained control case: let Ω be the time invariant set of admissible inputs, we write the extended k-step prediction strategy as:

$$\text{Min}_{e_n(j) \in \Omega} J(s_n(k) - u_n(k); k \in I) \quad (61)$$

where J is a criterion.

This optimization problem gives predicted inputs satisfying the constraints. Thus, one can expect to get a better behavior owing to the fact that predicted constraints are taken into account.

B-3.4 Choice from Behavior Analysis

The deconvolution model defines the tracking behavior with the following transfer obtained in a perfect modeling hypothesis.

$$S_a(z) = \frac{Fu(z)P(z)}{z Md(z)} \quad (62)$$

When we can take $Md(z)$ equal to $P(z)$ the set point predictor plays the

same role as the reference model in the MPHIC, so we can extend here the ideas of Rouhani [4].

B-3.4 Pole Placement

One can impose direct pole placement. In that case, from the specified polynomial $pp(z)$ we get the deconvolution model as:

$$Md(z) = \frac{mon(z)pp(z)}{md(z)} \quad (63)$$

because, in perfect modeling, we have

$$S_a(z) = \frac{Fu(z)}{z} \frac{mon(z)}{pp(z)} \quad (64)$$

This method is very simple when the factorization (39) is known. If not, this problem may be very difficult to solve numerically in particular when there is a great number of roots.

B-3.5 Optimization Criterion

Another natural criterion is the minimization of a quadratic distance between the expected and the actual responses to a set point sequence:

$$J(Md(z)) = \int_{-\pi}^{+\pi} \left| \frac{Fu(e^{i\theta})}{e^{i\theta}} \left(1 - \frac{M_c(e^{i\theta})}{M_d(e^{i\theta})} \right) u(e^{i\theta}) \right|^2 d\theta \quad (65)$$

where $u(e^{i\theta})$ is a specified function.

This is equivalent to a distance between deconvolution and convolution models. Thus, if we write

$$\begin{aligned}
 Md(z) &= \frac{mdn(z)}{md(z)} \\
 Mc(z) &= \frac{mcn(z)}{md(z)}
 \end{aligned}
 \tag{66}$$

The problem is to approximate the polynomial $mcn(z)$ whose roots are on both sides of the unit circle by a polynomial $mdn(z)$ whose roots are inside the unit circle and (65) can be rewritten as

$$J(mdn(z)) = \int_{-\pi}^{+\pi} \left| 1 - \frac{mcn(e^{i\theta})}{mdn(e^{i\theta})} \right|^2 dF(\theta)
 \tag{67}$$

with $dF(\theta)$ a positive measure and:

$$mdn(1) = mcn(1)
 \tag{68}$$

Such a criterion and constraints can be computed by the Jury-Astrom algorithm [15].

This method gives a deconvolution model which depends only on the convolution model Mc and the set point predictor (tracking coefficient in the exponential smoothing case). Those computations may be numerically easier than polynomial factorization, but have to be done again if the predictor is changed.

B-3.6 Conclusion

The deconvolution problem can be solved using a prediction strategy. This leads to a simple method but not manageable results in the k step prediction case or to more difficult computations as polynomial factorization or constrained nonlinear optimization if we want to have more manageable results.

B-4. Summary

We have shown that a very general implementation of a linear time invariant control law can be done by the adapted model algorithm control. This method uses five independent physical entities: two non-deterministic signal predictors which can be deduced from disturbance modelization; two mathematical representations of the process behavior which are also given by modelization; a set point predictor which can be deduced from the control law specification. The problem is complicated by the fact that one of the representations is used in a nonphysical way and thus has to be adapted by a further prediction strategy.

REFERENCES

1. JURY, E. I. (1964), Theory and Application of the z-Transform Method, New York: Wiley.
2. MAUJEAN, J. H. (1979), "Advanced Control of a Thermal Power Unit," Proc. IEEE Conf. on Decision and Control.
3. WOLOVICH, W. A. and P. FERREIRA (1978), "Output Regulation and Tracking in Linear Multivariable Systems," Proc. IEEE Conf. on Decision and Control.
4. ROUHANI, R. (1979), "SISO Constraint on Input," Progress Report, Scientific Systems, Inc.
5. HOUSEHOLDER, A. S. (1964), The Theory of Matrices in Numerical Analysis, Blaisdell.
6. GANTMACHER, F. R. (1966), "Théorie des Matrices," Tome 2, Dunod.
7. HOLLAND, A. S. B. (1973), Introduction to the Theory of Entire Functions, New York: Academic Press.
8. DOYLE, J. C. (1979), "Robustness of Multiloop Linear Feedback Systems," Proc. IEEE Conf. on Decision and Control.
9. BOX, G. E. P. and G. M. JENKINS (1970), Time Series Analysis, Forecasting and Control, Holden Day.
10. ASH, R. B. and M. F. GARDNER (1975), Topics in Stochastic Processes, New York: Academic Press.
11. PHILLIPSON, P. H. (1975), "Optimum Regulation of Sampled-Data Processes," Int. J. Control, Vol. 21, No. 5.
12. CAINES, P. E. (1972), "Relationship Between Box-Jenkins-Astrom Control and Kalman Linear Regulator," Proc. IEE, Vol. 119, No. 5.
13. RICHALET, J., A. RAULT, J. L. TESTUD and J. PAPON (1978), "Model Predictive Heuristic Control: Applications to Industrial Processes," Automatica, Vol. 14, pp. 413-428.
14. KAHAN-FOIGEL, J. (1980), "Analyse et Extension au cas Autoadaptatif d'une Commande Linéaire Predictive," Thèse de docteur ingénieur, Paris VI.
15. ASTROM, K. J. (1970), Introduction to Stochastic Control Theory, New York: Academic Press.

APPENDIX 1

Proof of the linear stability theorem.

Let $C_k(z), A(z), B(z)$ be three polynomials with the relation :

$$C_k(z) = (z-1)A(z) + k B(z) \quad (\text{A-1.1})$$

with \therefore degree of $A(z)$ greater than degree of $B(z)$

$$- B(1) \neq 0 \quad (\text{A-1.2})$$

- a_0 the highest degree coefficient of $A(z)$

- $A(z)$ has all its roots strictly in the unit circle

- $A(z), B(z)$ with real coefficients.

We will show that it exists a vicinity of zero $V(0)$ such that if k is in $V(0) - (0)$, the roots of $C_k(z)$ are strictly in the unit circle if and only if

$$k a_0 B(1) > 0 \quad (\text{A-1.3})$$

Proof : we use continuity results : the roots of a polynomial of the complex variable and the maximum of their moduli are continuous functions of its coefficients, the highest degree coefficient being taken different from 0.

So we have :

1 - For any real k , $C_k(z)$ has $(d_a + 1)$ roots if d_a is the degree of $A(z)$.

2 - For k equal to zero, the roots of $C_0(z)$ are :
the d_a roots of $A(z)$ which are strictly in the
unit circle

The simple root : equal to 1.

3 - From the preceding continuity properties, it
exists a vicinity $V(0)$ of zero such that for
any k in this vicinity, $C(z)$ has d_a roots
strictly in the unit circle.

4 - Let us study the last root.

If the modulus is greater or equal to one, the root is
real because it is alone outside the unit circle and the
coefficients of the polynomial $C(z)$ are real. So let us
consider the polynomial $C(z)$ of the real variable, its
only root greater than one exists iff :

$$C(1) - C(x) > 0 \quad (A-1.4)$$

for large x greater than one.

But here we have :

$$C(1) = k B(1) \quad (A-1.5)$$

and the sign of $C(x)$ for large x is the one of a_0 so
there is no root if :

$$kB(1) - a_0 > 0 \quad (A-1.6)$$

Remark : From the hypothesis on $A(z)$, the signs of
 $A(1)$ and a_0 are the same.

APPENDIX 2

Proof of the non linear stability theorem.

Let us take the notations :

$$E(n)^t = ((e_{n-M}^{-\bar{e}}) \dots (e_{n-N}^{-\bar{e}}) \dots (e_n^{-\bar{e}}))^t$$

$$m^t = (0 \dots 0 m_N \dots m_0)^t$$

$$S(n)^t = ((s_{n-N_d}^{-\bar{u}}) \dots (s_n^{-\bar{u}}))^t$$

$$W(n)^t = (w_{n-N_d} \dots w_n)^t$$

$$d^t = (d_{N_d} \dots d_0)^t$$

$$V(n)^t = (v_{n-L} \dots v_{n-N_b} \dots v_n)^t$$

$$b^t = (0 \dots 0 b_{N_b} \dots b_0)^t \tag{A-2.1}$$

$$U(n)^t = ((U_{n-N_r}^{-\bar{u}}) \dots (u_n^{-\bar{u}}))^t$$

$$r^t = (r_{N_r} \dots r_0)^t$$

$$\Pi = \begin{matrix} & \overbrace{\hspace{1.5cm}}^M & \\ \left[\begin{array}{cccccc} 0 & 1 & 0 & \dots & 0 \\ \cdot & \cdot & & & \\ \cdot & \cdot & \cdot & & \\ \cdot & \cdot & \cdot & \cdot & \\ \cdot & & & & 0 \\ & & & & 1 \\ 0 & & & & 0 \end{array} \right] & M \end{matrix}$$

$$\Gamma = \begin{matrix} & \overbrace{\hspace{1.5cm}}^M & \\ \left[\begin{array}{cccccc} p_{N_p} & \dots & p_0 & & 0 \\ \cdot & \cdot & & & \\ \cdot & \cdot & \cdot & & \\ \cdot & & & & \\ \cdot & & & & \\ 0 & & & \dots & \dots & 0 \end{array} \right] & N_d \end{matrix}$$

-and the process output (2) :

$$S(n) = \mathcal{P} E(n) + \mathcal{Q} V(n) + W(n) \quad (\text{A-2.4})$$

From the equality of static gains of the sensor and the reference, we have :

$$\bar{u} r^t t_0 = \bar{u} d^t t_0 \quad (\text{A-2.5})$$

So :

$$y_n = k r^t U(n) - kd^t \mathcal{P} E(n) - (kd^t \mathcal{Q} + b^t) V(n) - kd^t W(n) \quad (\text{A-2.6})$$

And :

$$e_{n+1} = f_n \left(\bar{e} + \frac{1}{m_0} \left[(m^t (\Pi - \mathcal{T}) - kd^t \mathcal{P}) E(n) + kr^t U(n) - (kd^t \mathcal{Q} + b^t) V(n) - kd^t W(n) \right] \right) \quad (\text{A-2.7})$$

Thus, we have a state representation of the control

$$E(n+1) = F_n (A E(n) + x_n t_1 + \bar{e} t_0) - \bar{e} t_0 \quad (\text{A-2.8})$$

with :

$$F_n \begin{vmatrix} x_1 \\ x_1 \\ x_0 \end{vmatrix} = \begin{vmatrix} x_1 \\ x_1 \\ f_n(x_0) \end{vmatrix} \quad (\text{A-2.9})$$

$$A = \begin{vmatrix} 0 & 1 & 0 \\ 0 & 0 & 1 \\ \frac{m^t}{m_0} (\mathcal{T} - \Pi) - \frac{kd^t}{m_0} \mathcal{P} \end{vmatrix} \quad (\text{A-2.10})$$

$$x_n = \frac{1}{m_0} (kr^t U(n) - (kd^t Q + b^t) v(n) - kd^t w(n)) \quad (A-2.11)$$

Now we remark that \mathbb{A} is a companion matrix associated to the polynomial :

$$(z-1)m(z)z^{N_p+N_d-N} + kd^t p_n(z)$$

So we have a new result of stability :

Let $\rho(\mathbb{A})$ be the spectral radius of the matrix \mathbb{A} , if f_n satisfies the following inequality for a certain norm :

$$\left\| \begin{array}{c} x_0 \\ \cdot \\ x_{N_p-1} \\ f_n(x_{N_p} + \bar{e}) - \bar{e} \end{array} \right\| < \frac{k}{\rho(\mathbb{A})} \left\| \begin{array}{c} x_0 \\ \cdot \\ x_{N_p-1} \\ x_{N_p} \end{array} \right\|, \quad k < 1 \quad (A-2.12)$$

Then the system with the non linearity f_n is stable.

Proof :

If the linear system is asymptotically stable, the spectral radius of \mathbb{A} is less than one, then it exists a consistent norm of \mathbb{A} which is less than one [5] .

For that norm, we have :

$$\|\mathbb{A}x\| < \rho(\mathbb{A}) \|x\|, \quad \rho(\mathbb{A}) < 1 \quad (A-2.13)$$

So :

$$\|\mathbb{A}E(n) + x_n t_1\| < \rho(\mathbb{A}) \|E(n)\| + |x_n| \|t_1\| \quad (A-2.14)$$

But from (42), we have also :

$$\|F_n(\mathbb{A}E(n) + x_n t_1 + \bar{e}t_0) - \bar{e}t_0\| < \frac{k}{\rho(\mathbb{A})} \|\mathbb{A}E(n) + x_n t_1\| \quad (A-2.15)$$

So :

$$\|E(n+1)\| \leq k(\|E(n)\| + \frac{|x_n| \cdot \|t_1\|}{\rho(A)}) \quad (A-2.16)$$

Then if x_n is bounded i.e. set-point, measured and unmeasured disturbances are bounded, we can conclude our proof.

APPENDIX 3

Spectral analysis of the matrix $(\cos(i-j)\theta)$.

From the relation :

$$\cos(i-j)\theta = \cos i\theta \cdot \cos j\theta + \sin i\theta \sin j\theta, \quad (\text{A-3.1})$$

we can write :

$$\begin{pmatrix} \cdot \\ \cdot \\ \cdot \\ \cdot \\ \cdot \end{pmatrix} \cos(i-j)\theta \begin{pmatrix} \cdot \\ \cdot \\ \cdot \\ \cdot \\ \cdot \end{pmatrix} = \begin{pmatrix} \cdot \\ \cdot \\ \cdot \\ \cdot \\ \cdot \end{pmatrix} \cos i\theta \begin{pmatrix} \cdot \\ \cdot \\ \cdot \\ \cdot \\ \cdot \end{pmatrix} (\cos j\theta) + \begin{pmatrix} \cdot \\ \cdot \\ \cdot \\ \cdot \\ \cdot \end{pmatrix} \sin i\theta \begin{pmatrix} \cdot \\ \cdot \\ \cdot \\ \cdot \\ \cdot \end{pmatrix} (\sin j\theta) \quad (\text{A-3.2})$$

So we see that the matrix is semi definite positive with only two positive eigen values. We are looking for the eigen vectors as a linear combination :

$$x \begin{pmatrix} \cdot \\ \cdot \\ \cdot \\ \cdot \\ \cdot \end{pmatrix} \cos j\theta + y \begin{pmatrix} \cdot \\ \cdot \\ \cdot \\ \cdot \\ \cdot \end{pmatrix} \sin j\theta$$

We have to find x and y such that :

$$\begin{aligned} \begin{pmatrix} \cdot \\ \cdot \\ \cdot \\ \cdot \\ \cdot \end{pmatrix} \cos i\theta \left(x \cdot \sum_{j=0}^M \cos^2 j\theta + \sum_{j=0}^M \cos j\theta \sin j\theta \right) &= xy \begin{pmatrix} \cdot \\ \cdot \\ \cdot \\ \cdot \\ \cdot \end{pmatrix} \cos i\theta \\ + &= + \quad (\text{A-3.3}) \\ \begin{pmatrix} \cdot \\ \cdot \\ \cdot \\ \cdot \\ \cdot \end{pmatrix} \sin i\theta \left(x \cdot \sum_{j=0}^M \cos j\theta \sin j\theta + \sum_{j=0}^M \sin^2 j\theta \right) &= y \begin{pmatrix} \cdot \\ \cdot \\ \cdot \\ \cdot \\ \cdot \end{pmatrix} \sin i\theta \end{aligned}$$

We deduce the expressions :

$$xA + B = xy$$

$$xB + C = y \quad (\text{A-3.4})$$

$$\text{with } A = \sum_{j=0}^M \cos^2 j\theta$$

$$B = \sum_{j=0}^M \sin j\theta \cos j\theta \quad (\text{A-3.5})$$

$$C = \sum_{j=0}^M \sin^2 j\theta$$

We get :

$$x^2 B + x(C-A) - B = 0 \quad (\text{A-3.6})$$

$$x = \frac{A-C + \left((C-A)^2 + 4B^2 \right)^{\frac{1}{2}}}{2B} \quad (\text{A-3.7})$$

$$y = \frac{A+C + \left((C-A)^2 + 4B^2 \right)^{\frac{1}{2}}}{2}$$

but :

$$A+C = M+1$$

$$A-C = \sum_{j=0}^M \cos^2 j\theta = \left| \frac{\sin(M+1)\theta}{\sin \theta} \right| \cos \frac{M}{2}\theta \quad (\text{A-3.8})$$

$$2B = \sum_{j=0}^M \sin^2 j\theta = \left| \frac{\sin(M+1)\theta}{\sin \theta} \right| \sin \frac{M}{2}\theta$$

So :

$$x = \frac{\cos \frac{M}{2}\theta + 1}{\sin \frac{M}{2}\theta} \quad (\text{A-3.9})$$

$$y = \frac{M+1}{2} + \frac{1}{2} \left| \frac{\sin(M+1)\theta}{\sin \theta} \right|$$

APPENDIX 4Proof of the AMAC Stability

We have to study the roots of the expression

$$c(z) + d(z)P(z) = z \cdot M_d(z) + F_w(z)(P(z) - M_c(z)) \quad (\text{A4.1})$$

Let us take:

$$\begin{aligned} M_d(z) &= \frac{mdn(z)}{md(z)} \\ F_w(z) &= \frac{fwn(z)}{fwd(z)} \\ P(z) &= \frac{fn(z)}{fd(z)} \\ M_c(z) &= \frac{mcn(z)}{m\#d(z)} \end{aligned} \quad (\text{A4.2})$$

The characteristic polynomial is then:

$$g(z) = z \cdot mdn(z) \cdot fwd(z) \cdot pd(z) + fwn(z) \cdot [pn(z) \cdot md(z) - pd(z) \cdot mcn(z)] \quad (\text{A4.3})$$

We see directly that if the process is known:

$$pn(z) \cdot md(z) - mcn(z) \cdot pd(z) = 0 \quad (\text{A4.4})$$

and we have a necessary condition for stability: $mdn(z)$, $fwd(z)$ must have their roots strictly in the unit circle.

In the general case, to make no more hypothesis on the process, we

will use the result of Appendix 1. A direct application is in writing the characteristic polynomial as:

$$g(z) = (z-1)A(z) + kB(z) \quad (A4.5)$$

$$(z-1)A(z) = (z \cdot \text{mdn}(z) \cdot \text{fwd}(z) - \text{mcn}(z) \cdot \text{fwn}(z)) \text{pd}(z) \quad (A4.6)$$

$$B(z) = \text{fwn}(z) \cdot \text{pn}(z) \cdot \text{md}(z)$$

But this leads to consider the model's static gain as the stability coefficient and thus to lose the notion of model. Moreover, the hypothesis on $A(z)$ implies coupled conditions on the models and the unmeasured disturbance predictor and here we lose the physical independence of these elements.

To keep the AMAC coherence, let us factorize $z \cdot \text{fwd}(z)$ in:

$$z \cdot \text{fwd}(z) = (z-1)\text{gwd}(z) + \text{rwd}(z) \quad (A4.7)$$

such that degree of $\text{gwd}(z)$ is greater or equal to degree of $\text{rwd}(z)$ and $\text{gwd}(z)$ has all its roots strictly in the unit circle. Such a factorization exists always and moreover we have:

- degree of $\text{gwd}(z)$ is equal to degree of $\text{fwd}(z)$;
- the highest degree coefficients of $\text{gwd}(z)$ and $\text{fwd}(z)$ are equal;
- $\text{fwd}(1) = \text{rwd}(1)$ (A4.8)

Then with a modified $\text{fwd}_k(z)$ defined as:

$$z \cdot \text{fwd}_k(z) = \frac{1}{k}(z-1)\text{gwd}(z) + \text{rwd}(z) \quad (A4.9)$$

the characteristic polynomial can be written as:

$$\begin{aligned}
g(z) = & (z-1) \cdot \text{mdn}(z) \text{ gwd}(z) \cdot \text{pd}(z) \\
& + k[\text{fwn}(z) \cdot \text{pn}(z) \cdot \text{md}(z) + \text{pd}(z) \cdot \text{mdn}(z) \text{rwd}(z) - \text{pd}(z) \\
& \cdot \text{mcn}(z) \cdot \text{fwn}(z)] \tag{A4.10}
\end{aligned}$$

And Appendix 1 ensures stability if k is in a vicinity of zero and

$$(\text{mdn}(1) \cdot \text{gwd}(1) \cdot \text{pd}(1)) \cdot k \cdot (\text{fwn}(1) \cdot \text{pn}(1) \cdot \text{md}(1)) > 0 \tag{A4.11}$$

using:

$$\begin{aligned}
\text{mdn}(1) &= \text{mcn}(1) \\
\text{rwd}(1) &= \text{fwd}(1) = \text{fwn}(1)
\end{aligned} \tag{A4.12}$$

But (A4.11) can also be written as:

$$(k \text{ gwd}(1) \text{ rwd}(1)) \cdot (\text{Md}(1) \cdot \text{P}(1)) > 0 \tag{A4.13}$$

where the first term is the inequality condition to have all the roots of $z \cdot \text{fwd}_k(z)$ strictly in the unit circle we must impose as a necessary condition. We thus obtain the AMAC stability theorem:

Let $\text{fwd}_k(z)$ be the modified denominator of the unmeasured disturbance predictor, there exists a vicinity of zero $V(0)$ such that if k is in $V(0) - \{0\}$ the roots of:

$$z \cdot \text{Md}(z) \cdot \text{fwd}_k(z) + \text{fwn}(z) \cdot (\text{P}(z) - \text{Mc}(z))$$

are strictly in the unit circle if: $\text{Md}(z)$ and $\text{fwd}_k(z)$ have all their roots strictly in the unit circle and: $\text{Md}(1) \cdot \text{P}(1) > 0$.