



HAL
open science

Formability investigations for the hot stamping process

Yoann Dahan, Yvan Chastel, Patrick Duroux, Philipp Hein, Elisabeth Massoni, Joël Wilsius

► **To cite this version:**

Yoann Dahan, Yvan Chastel, Patrick Duroux, Philipp Hein, Elisabeth Massoni, et al.. Formability investigations for the hot stamping process. International Deep Drawing Research Group (IDDRG) 2006 International Conference, Jun 2006, Porto, Portugal. 8 p. <hal-00566427>

HAL Id: hal-00566427

<https://minesparis-psl.hal.science/hal-00566427v1>

Submitted on 16 Feb 2011

HAL is a multi-disciplinary open access archive for the deposit and dissemination of scientific research documents, whether they are published or not. The documents may come from teaching and research institutions in France or abroad, or from public or private research centers.

L'archive ouverte pluridisciplinaire **HAL**, est destinée au dépôt et à la diffusion de documents scientifiques de niveau recherche, publiés ou non, émanant des établissements d'enseignement et de recherche français ou étrangers, des laboratoires publics ou privés.



HAL Authorization

FORMABILITY INVESTIGATIONS FOR THE HOT STAMPING PROCESS

Y. Dahan ^{1&2,*}, Y. Chastel ¹, P. Duroux ², P. Hein ², E. Massoni ¹, J. Wilsius ²

¹ CEMEF, Ecole Nationale Supérieure des Mines de Paris, 1 rue Claude Daunesse, BP 207, 06904 Sophia-Antipolis Cedex, France

² ARCELOR Research Automotive Applications, 1 route de Saint-Leu, BP 30109, 60761 Montataire Cedex, France

* corresponding author: yoann.dahan@ensmp.fr

Abstract

Arcelor Research is developing a numerical tool to support the feasibility analysis and to optimize the design of hot stamped parts made of USIBOR 1500P[®]. To provide formability data and to feed the development of a fracture criterion, experimental hot stamping tests are carried out at Cemef (Centre for Material Forming). These hot stamping experiments are based on a modified Nakazima-type test. Results reveal that the achievable strain levels depend on process parameters (stroke, velocity, temperature, friction and heat exchange) and blank parameters (initial temperature, thickness and shape). In parallel, a numerical model of these hot stamping tests has been developed with finite element softwares (Forge2[®], Forge3[®] and Abaqus). The numerical simulations confirm the location and the magnitude of the blank thinning. Furthermore, the numerical results are similar to the experimental measurements in terms of punch load, cooling rate and strain distribution. A formability analysis is then performed to study the influence of the blank geometry and the blank temperature on formability.

Keywords: Formability, Hot Stamping, Experiment, Numerical Simulation

1. Introduction

The objective of automotive manufacturers is to combine safety improvements and weight reductions of their vehicles in order to comply with CO₂ emission regulations. A non exhaustive list of the industrial solutions is given in [1]. As a response to these constraints, the hot stamping process of quenchable steels allows to obtain thinner parts with higher mechanical properties. It is a relatively novel process and it is increasingly used for automotive applications. This process consists in first heating up a blank in a furnace to reach a stable austenitic state. The hot blank is then moved into a stamping press where it is simultaneously stamped and quenched by the cold tools. The cooling rate of this process step allows obtaining the desired martensitic microstructure leading to superior mechanical properties on the formed part. It is the reason why the main target components are in the crash relevant parts of car structures: bumpers, side impact reinforcements, A- and B- pillars (see **Figure 1**). For this process, Arcelor developed USIBOR 1500P[®]¹, a quenchable C-Mn steel micro-alloyed with boron. The distinctive value of USIBOR[®] lies in the coating which avoids oxidation during the heating phase and saves a very expensive shot-peening step. With this material, a tensile strength of about 1500 MPa is reached on the quenched formed part. More details on the material, the process and some market trends are available in [2].

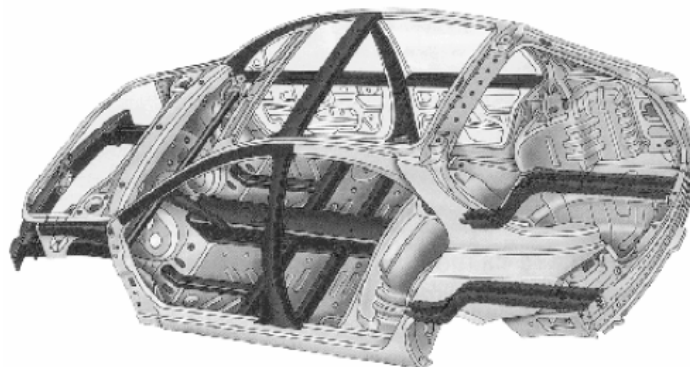

Figure 1. Crash relevant components hot stamped in USIBOR 1500 P[®] (darkened parts) [3]

¹ USIBOR[®] is a registered trademark belonging to the Arcelor Group and protected throughout the world. Furthermore, Arcelor Group has filed numerous patents covering the principle of direct or indirect hot-stamping process of either aluminized-coated steel sheets and zinc or zinc-alloy coated steel sheets, and of the issued parts.

Arcelor is developing a numerical tool to support the feasibility analysis and the design of hot stamped parts made of USIBOR 1500P[®]. This task is challenging due to the high number of process parameters, the thermo-mechanical and metallurgical interactions and their influence on formability (more details are presented in [3]). This requires both experimental tests and advanced numerical simulation tools. To provide formability data and to support the development of a fracture criterion, experimental hot stamping tests are carried out at Cemef (Centre for Material Forming). In this article we will mainly focus on the experimental results and the comparisons with the numerical simulations.

Three types of non-conformities can be observed on hot stamped parts. They prevent from reaching the targeted mechanical properties defined in the specifications. First, the blank may only be partially quenched and thus not fully martensitic. The second type of non-conformity concerns the wrinkling and thickening zone. These defects are usually decreased by reducing the clearance between the die and the blank-holder or optimizing the initial blank shape. In this article, we will focus on the necking and/or fracture of the blank during hot stamping.

2. Process description

To establish the formability criterion, hot stamping tests are performed with modified Nakazima-type tools and various product/process conditions. The axisymmetrical set-up is made of a hemispherical punch, a die, a blank-holder and a draw-bead which prevents any sliding motion (see **Figure 2**). Several parameters are recorded in-situ, such as the punch load and the local temperature history. A grid is etched on the blank and allows determining the strain distribution using pattern recognition systems.

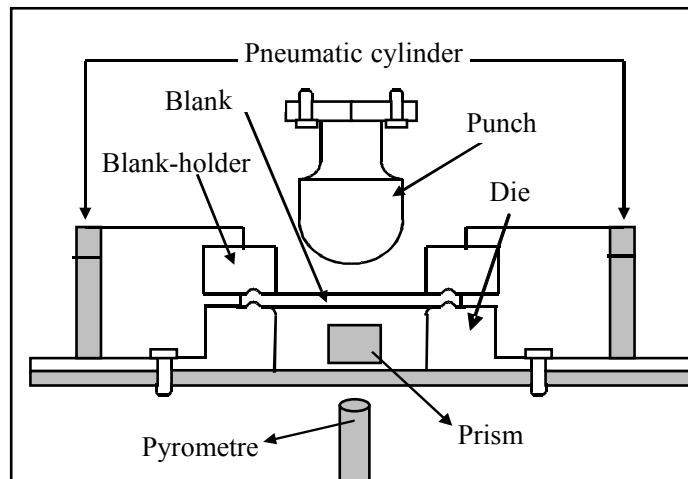

Figure 2. Axi-symmetrical set-up for the modified Nakazima hot stamping tests

Numerical simulation has been initially used for the physical understanding of the process. Numerical models of these hot stamping tests have been developed with different finite element softwares (Forge2[®], Forge3[®] and Abaqus). Forge2[®] and Forge3[®] are being constantly improved at Cemef respectively for 2D and 3D analysis. Besides Arcelor developed a finite element environment dedicated to hot stamping in order to perform coupled thermo-mechanical simulations and make feasibility studies of hot stamped components [3].

In order to obtain correct results, a large number of model parameters have to be either defined with additional experimental tests (e.g. heat exchange coefficient, flow behavior) or adjusted by inverse identification (e.g. friction, heat radiation). Some of them are defined in [4]. In this section, we will present the numerical results for a punch velocity of 30 mm/s, a 1,5 mm thick blank and an initial blank temperature of 780°C (when the forming starts). In the post-processing, we can see the temperature and strain rate distribution at different steps of the process (see **Figure 3**). A high cooling rate is measured at the centre of the blank, which is in contact with the punch. Nevertheless, the temperature of the free blank zone seems to be roughly constant during the process. The distribution of the Von Mises equivalent strain rate indicates an obvious strain localization in a zone called punch radius exit. Indeed, during the hot stamping process, the strains are usually localized in the hotter regions (free blank zone in our case), and especially at the exit of the punch radius.

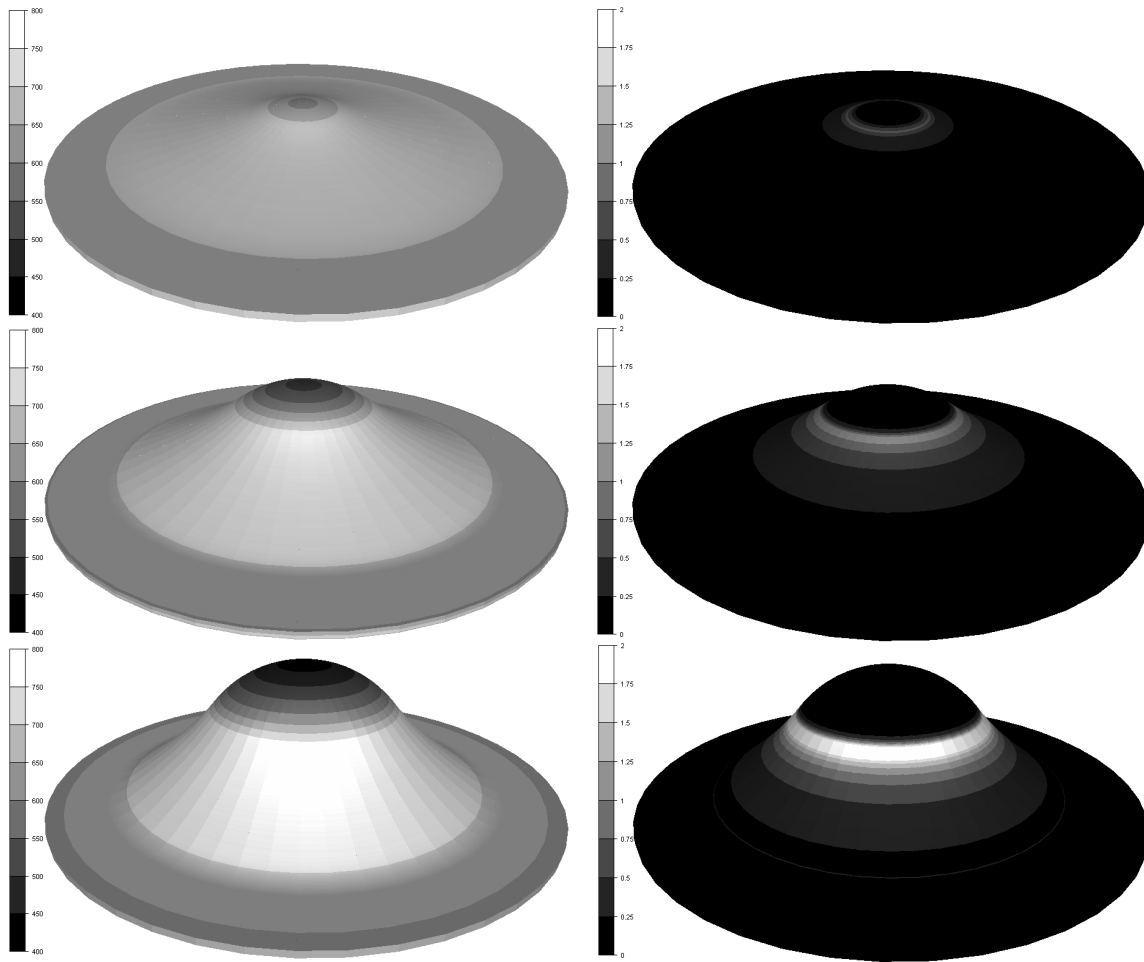

Figure 3. Results of numerical simulation for 10, 20 and 30 mm punch strokes:
Evolution of the temperature [°C] (left) and Von Mises equivalent strain rate [1/s] (right)

Numerical simulation enables us to give results all along the process at a given location. Selecting a node near the exit of the punch radius, we plotted the nodal evolutions of the temperature and the equivalent strain rate in **Figure 4**. From 0 to 0,6 s, the punch is not in contact with the chosen node of the blank. So, obviously, it is at a constant temperature. The strain rate is increasing and reaches a maximum value at 0,6 s. At this moment, the node comes in contact with the punch and it is quickly cooled. As soon as the temperature drops down, the strain rate goes down as well. In fact, during the first time of the process, the blank centre is deformed and cooled down simultaneously. When this central zone is cool enough, the surrounding region, which is obviously hotter, is then deformed by the punch. In fact, due to the punch motion, a strain and a cooling wave is propagated away from the blank centre towards the exit of the punch radius.

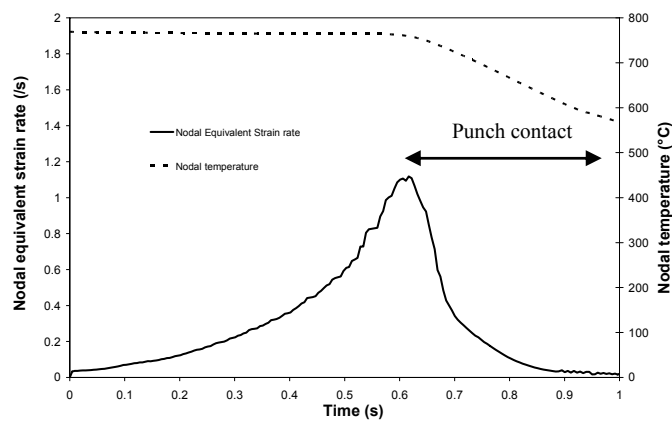

Figure 4. Nodal evolution of the temperature and of the equivalent strain rate during the process

Using an axisymmetric configuration enables us to check the model parameters defined previously. **Figure 5** illustrates accurate comparisons between the numerical results and the experimental measurements for the punch load and the temperature at the centre of the blank. The punch force is directly dependent on the viscoplastic flow behavior of the material, the initial blank temperature and the blank thickness. The temperature distribution is mainly defined by the initial temperature gradient between the punch and the blank, and by the heat exchange coefficients. In [4], Garcia-Aranda et al. determined this coefficient as a function of the contact pressure and the clearance between the tool and the blank. This analysis confirms the accuracy of the parameters used to develop the numerical model.

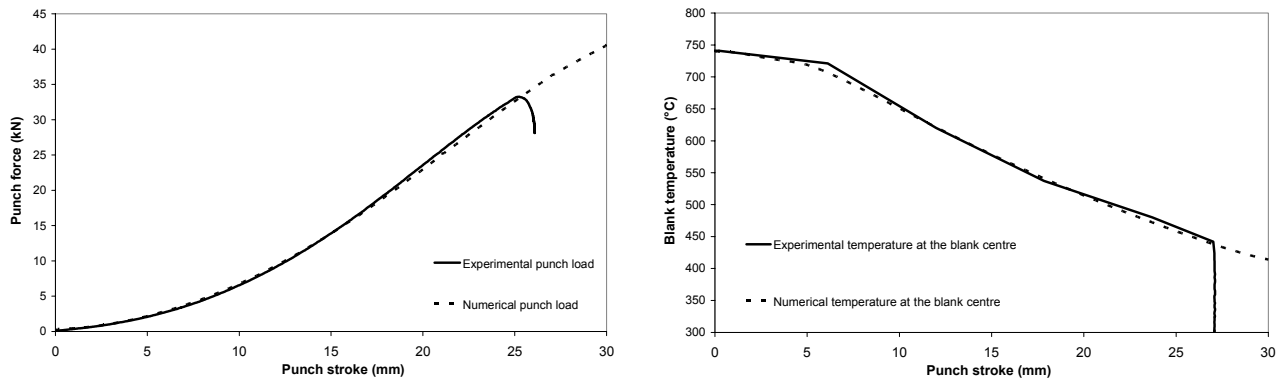

Figure 5. Experimental measurements and numerical calculations during the hot stamping process punch force (left) and temperature at the centre of the blank (right)

The numerical model being checked and validated, we now focus on the strain distributions which are the key point for the formability analysis.

3. Predicted and experimental strain distributions

Three types of stamped blanks can be obtained: conformed, with strain localization or fractured blank (see **Figure 6**). For a safe punch stroke, the blank shows no critical damage. For a higher punch stroke, a strain localization occurs in the exit of the punch radius which causes a local thinning called necking and can be determined by a technique developed by Hecker [5]. Once the maximum punch stroke is reached, the necking leads to a fracture which spreads over the exit zone of the punch radius.

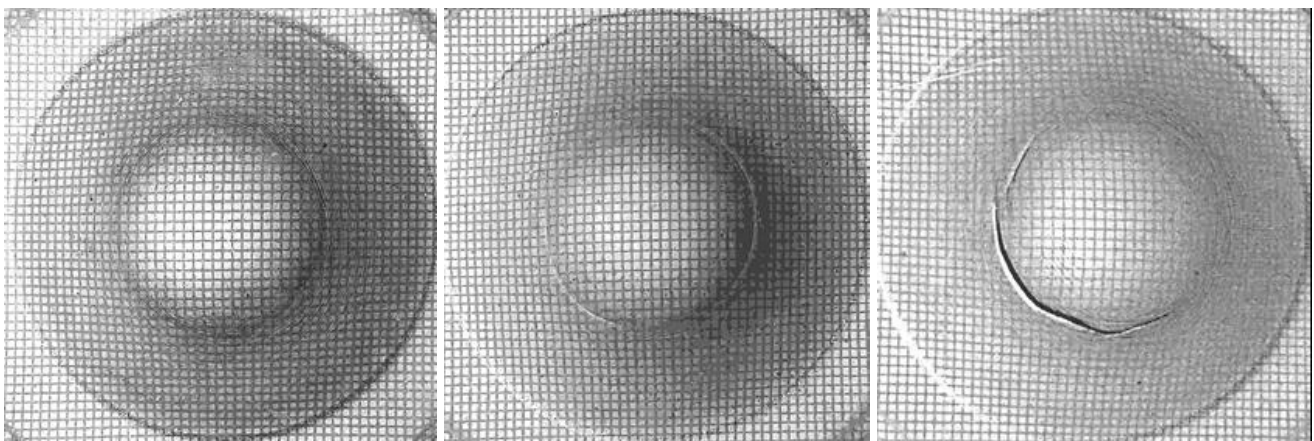

Figure 6. Conformed (left), necked (middle) and fractured (right) hot stamped blanks for various punch strokes.

Fractography analysis has been carried out in order to analyze the fracture mode. In **Figure 7**, we observe a cross-section of the fractured zone. During hot stamping, strain localization occurs in the hotter region which leads to the thinning of the blank. The thinning appears in both a concentrated and continuous manner close to the fracture region. In addition, it seems to be symmetrical with respect to the blank neutral line. The front view of the fracture has been obtained by SEM. At the centre, the damage mode of the steel is observed in terms of intragranular microvoids characterizing a ductile fracture.

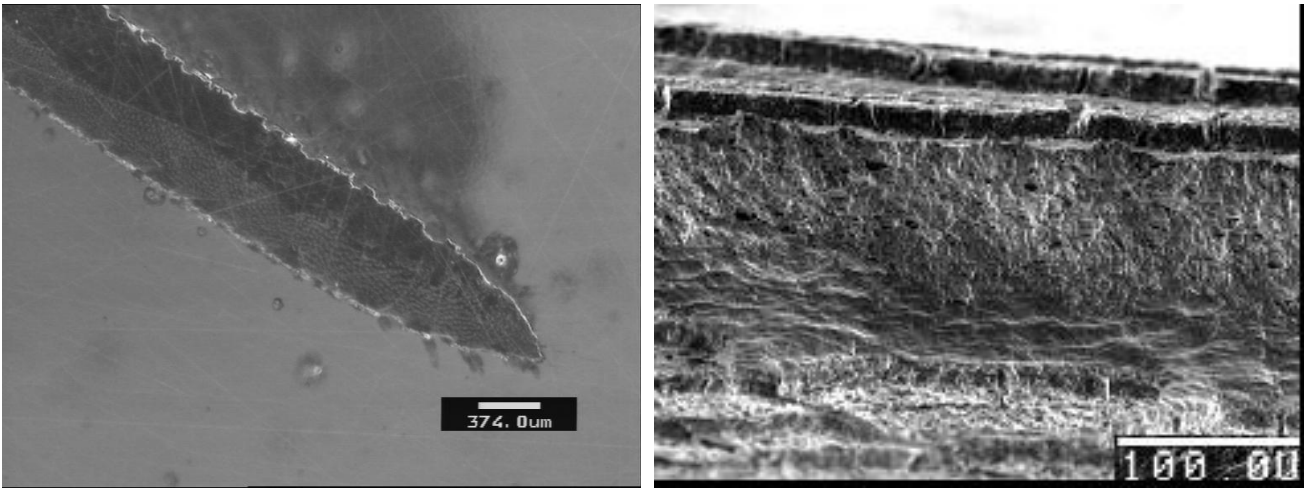

Figure 7. Fractography analysis: binocular cross-section (left) and SEM front view (right) of the fracture zone

Thanks to the quality of the coating and to an accurate method to preserve the grid, we managed to assess several strain distributions using pattern recognition systems. Uniform and random grids have been etched or painted on to the blank to be respectively analyzed by Asame and Aramis. This technique enables us to measure the strain distributions. The thinning values are then calculated considering volume conservation. **Figure 8** compares the results given by Forge3[®] and Aramis for similar process configurations. The numerical simulations confirm the location and the magnitude of the thinning. Indeed, Aramis and Forge3[®] estimate that the maximum major strain is reached at the exit of the punch radius and that this extreme value was roughly 0,4. We can also notice that the blank centre is only slightly deformed due to the high cooling rate generated by the early contact with the punch.

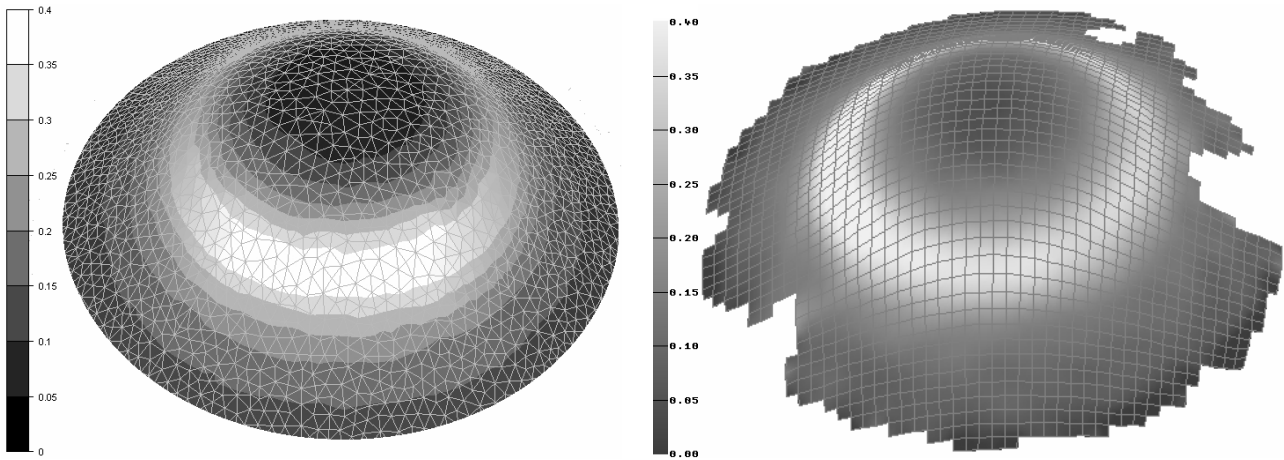

Figure 8. Major surface strain distributions obtained by Forge3[®] (left) and Aramis (right)

Process conditions: punch stroke: 30 mm, punch velocity: 30 mm/s, blank thickness: 1,5 mm, blank initial temperature: 780°C

The pattern recognition systems such as Asame and Aramis enable us to plot the strain distribution in the (ϵ_1, ϵ_2) space. This diagram is widely used for sheet metal forming when strain gradients in the thickness direction can be neglected. **Figure 9** represents the numerical and the experimental strain states of the blank at the end of the hot stamping process. First of all, we can observe an excellent correlation between the numerical and the experimental results. In our simple configuration, strains are located between plane strain and biaxial expansion. Forge2[®] and Aramis results indicate that the maximum major strain is reached in a mixed mode, close to plane strain. The blank centre is obviously in an expansion state. We see that the major strain is 0,05 at the blank centre which is roughly the ratio of the blank thickness to the punch radius. According to [5], this value could be a simple bending effect due to the accumulated effects of high friction and heat exchange. The central zone of the blank quenched by the punch reaches a constant minor strain ($\approx 0,04$) all the way to the punch radius exit. In this region, the further from the blank centre, the higher the major strain. Beyond the punch radius exit zone, the strain quickly decreases.

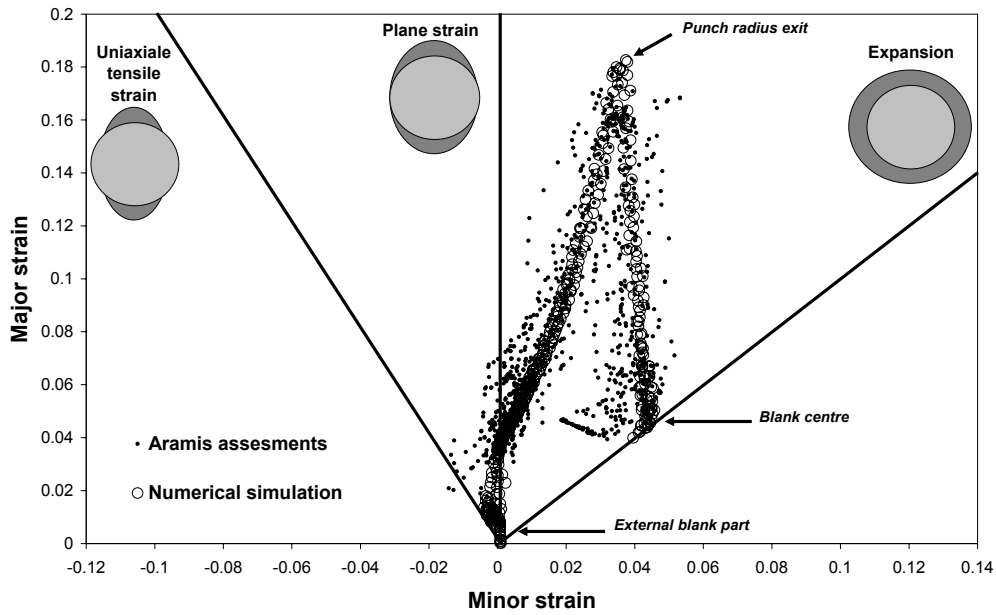

Figure 9. Strain distribution given by Aramis assessments and Forge2[®] results

Process conditions: punch stroke: 20 mm, punch velocity: 30 mm/s, blank thickness: 1,5 mm, blank initial temperature: 780°C

4. Formability analysis

The experimental determination of formability limits has to take into account several process characteristics in terms of temperature (anisothermal process), phase transformation (unstable austenitic structure), stress triaxiality (thickness effect), process speed (viscoplastic behaviour and heat transfer) and strain path (blank shape and friction). These parameters can be changed by varying the process time, the initial blank temperature (defined as the blank temperature at the start of the stamping), the thickness and the blank shape in order to analyze their respective influence on the formability. Only the influence of the blank shape and the of the initial temperature of the blank will be detailed in this article.

Several hot stamping tests were performed for different blank widths. Each stamped blank is then analyzed and classified according to quality criteria. All failed blanks showed necking or fracture in the punch radius region (see **Figure 10**). The punch stroke is then plotted as a function of the blank width for safe parts, strain localization (necking) or fractured blanks. The formability is strongly dependent on the blank width: the larger the blank width, the lower the critical punch stroke. This observation is mainly due to the modification of the strain paths of the critical region from plane strain towards uniaxial tensile strain.

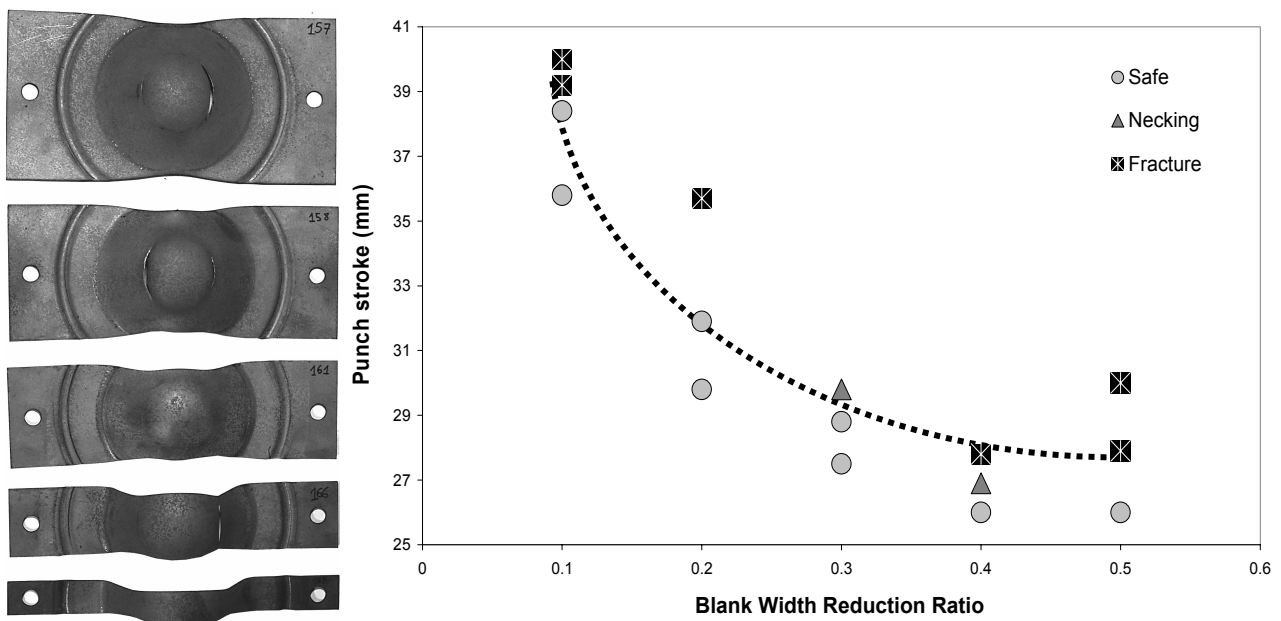

Figure 10. Hot stamped blanks with different width reduction ratios (left) and influence of the blank width on formability (right)

The pattern recognition systems have been used to deduce the influence of the width on the strain distribution. The strain states for several widths of necked blanks are shown in **Figure 11**. Several remarks can be made from this graph. The lower the blank width reduction ratio, the closer to the uniaxial tensile mode is the strain state and the higher is the maximum major strain. As seen before, the critical and the expansion zones are still respectively the exit of the punch radius and the blank centre for the higher width. The strain value at the centre seems to be constant for all blank widths. Of course, the blank centre zone is not in an expansion state anymore for the narrowest blanks.

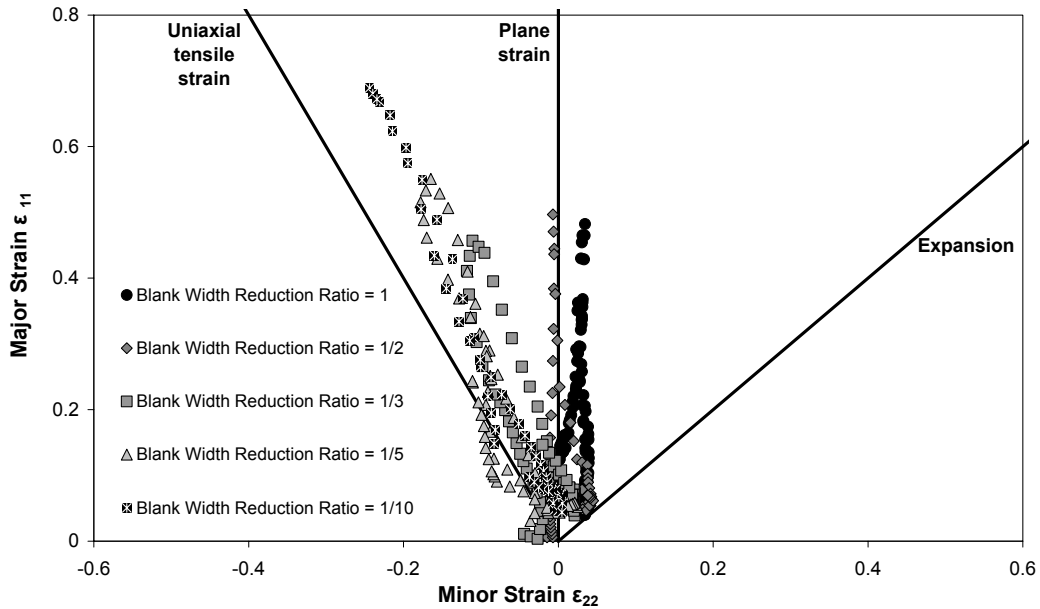

Figure 11. Influence of the blank width on punch stroke and formability

Asai et al. studied the influence of the heating temperature on the deep drawability of a hardenable C-Mn-B steel sheet [7]. In our case, varying the initial blank temperature from 600°C to 800°C allows us to analyze the influence of temperature on the formability. **Figure 12** confirms the influence of temperature: the higher the initial temperature, the higher is the maximum punch stroke. According to these experimental results and with the given process conditions, a stroke of 27 mm is feasible only if the initial blank temperature is higher than 720°C. Below this temperature, necking and fracture in the critical zone of the blank are strongly likely.

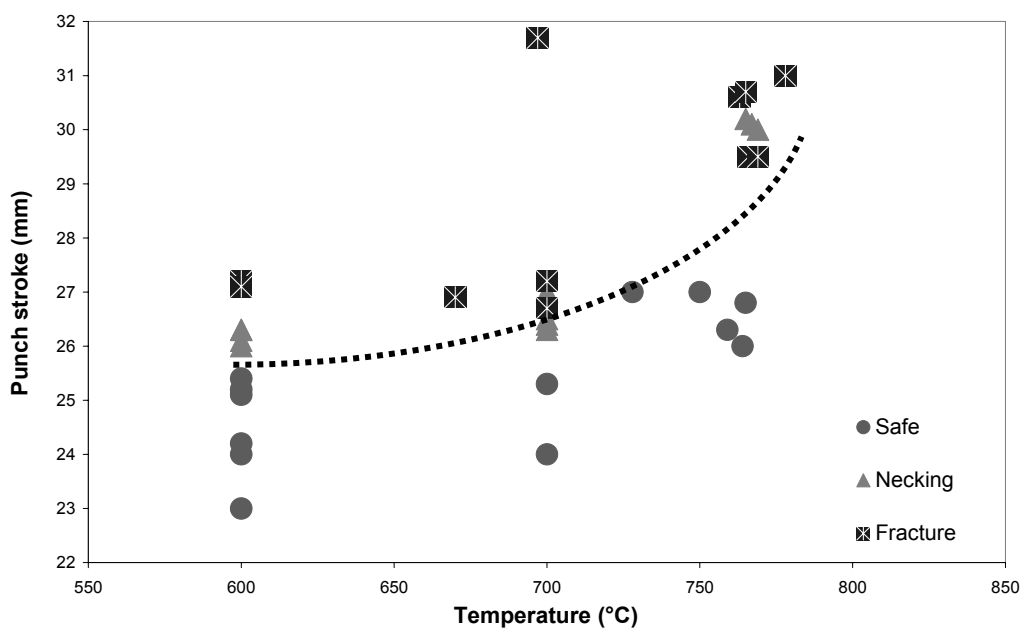

Figure 12. Influence of the initial blank temperature on the punch stroke and the formability of the blank

5. Conclusion

Hot stamping tests have been carried out with a modified Nakazima set-up. Safe parts, strain localization (necking) and fractured blanks were obtained. The fractography analysis of the fractured blanks shows intragranular microvoids characterising a ductile fracture. Thanks to the quality of the blank coating and to an accurate method to preserve the grid, we managed to assess several strain distributions using pattern recognition systems.

Numerical simulations have been performed and show an accurate correlation with the experimental results in terms of punch load, temperature at the center of the blank and strain distribution. The numerical model confirms the location and the magnitude of the critical zone. Numerical simulations enable us to analyze the evolution of temperature and strain rate during stamping as a wave which propagates from the blank centre towards the die radius, following closely the exit of the punch radius.

Formability analysis results show the influence of the width and the initial temperature of the blank. For the first analysis, the narrower the blank, the higher is the allowable punch stroke. Modifying the blank shape changes the strain path. Indeed, the strain distribution graph shows that the narrower the blank, the closer to the uniaxial tensile mode is the strain state and the higher is the maximum major strain. A similar study has been performed for the influence of the initial blank temperature. It appears that the higher the initial temperature, the better is the formability.

All these tests will be used to develop a necking criterion which takes into account several process parameters such as the blank temperature, the blank thickness and the strain rate.

6. References

- [1] Kolleck, R.; Steinhöfer, D.; Feindt, J.-A.; Bruneau, P.; Heller, T.; Lenze, F.: Manufacturing Methods For Safety and Structural Body parts for Lightweight solution. IDDRG 2004. Proc. of the conf. of the Int. Deep Drawing Research Group, p. 167-173, 2004.
- [2] Hein, P.; Kefferstein, R.; Dahan, Y.: Hot Stamping of USIBOR 1500P[®]: Part and Process Analysis Based on Numerical Simulation. Proc. of the conf. New Developments in Sheet Metal Forming, Institute for Metal Forming Technology, Stuttgart, Germany, May 2006
- [3] Hein, P.: A Global Approach of the Finite Element Simulation of Hot stamping, Advanced Materials Research, Vol. 6-8 (May 2005), 763-770. Trans. Tech Publications Ltd., Switzerland.
- [4] Garcia-Aranda, L.: Etude thermo-mécanique et modélisation numérique de l'emboutissage à chaud de l'USIBOR 1500P[®]. Ecole des Mines de Paris. PhD-Thesis (in French), 191p, 2004.
- [5] Hecker, S.S.: Formability of Aluminium Alloy Sheets. ASME Journal of Engineering Materials and Technology, Vol. 97, 66-73, 1975
- [6] Wang, G.; Ohtsubo, H.; Arita, K.: Large Deflection Of A Rigid-Plastic Circular Plate Pressed By A Sphere. Journal of Applied Mechanics, 533, Vol. 65, June 1998.
- [7] Asai, T.; Iwaya, J.: Hot Stamping Drawability of Steel. IDDRG 2004. Proc. of the conf. of the Int. Deep Drawing Research Group, p. 344-354, 2004.

Acknowledgements

The authors would like to thank S. Jacomet, G. Fiorucci and B. Triger from Centre for Material Forming (CEMEF) and C. Dessain, J.-P. Durbise and B. Tavernier from Arcelor Research Automotive Applications.