



**HAL**  
open science

## Choice Criteria between AC and DC Bus in a subsystem in the frame of a distributed Power production

Céline Trousseau, Georges Kariniotakis

► **To cite this version:**

Céline Trousseau, Georges Kariniotakis. Choice Criteria between AC and DC Bus in a subsystem in the frame of a distributed Power production. *Med Power* 2002, Nov 2002, Athènes, Greece. hal-00534354

**HAL Id: hal-00534354**

**<https://minesparis-psl.hal.science/hal-00534354>**

Submitted on 4 May 2018

**HAL** is a multi-disciplinary open access archive for the deposit and dissemination of scientific research documents, whether they are published or not. The documents may come from teaching and research institutions in France or abroad, or from public or private research centers.

L'archive ouverte pluridisciplinaire **HAL**, est destinée au dépôt et à la diffusion de documents scientifiques de niveau recherche, publiés ou non, émanant des établissements d'enseignement et de recherche français ou étrangers, des laboratoires publics ou privés.

# Choice Criteria Between AC and DC Bus in a Subsystem in the frame of a Distributed Power Production

Céline Trousseau, Georges Kariniotakis

École des Mines de Paris, BP 207, F-06904 Sophia-Antipolis Cedex  
Phone +33-4 93 95 75 99 – Fax +33-4 93 95 75 35 – kariniotakis@ensmp.fr

**ABSTRACT:** The aim of the paper is to provide a framework for the evaluation of the operational performance of small electricity supply systems (1–10 kW) that use either AC or DC bus. It is shown that in several cases a better performance can be achieved when generators and loads are connected to a common DC rather than a standard AC bus. The application study is performed for the case of a PV pumping system. The influence of bus and inverter choice is studied, while the distance between solar generator and battery is introduced as a decisive criterion. The paper introduces loss of load, AC↔DC conversion losses and new economic criteria that permit optimal decisions on the choice between AC or DC bus-bar.

**Keywords:** stand-alone system, photovoltaic, PV pumping, AC bus, modular, load management

## I. INTRODUCTION TO AC BUS TECHNOLOGY

Small electricity supply systems based on renewable energy sources up to 10 kW are nowadays used for remote, island, rural and other applications. Often they integrate units like photovoltaic (PV) arrays connected to a DC bus fed by low-voltage battery banks. Such a system is able to supply common AC devices by the use of an inverter.

A new concept of hybrid systems has emerged [1], based on AC modular components. The main characteristic is that the components are connected through the standard AC bus (230 V, 50 Hz). The advantage of such a modular technology is that it enables the easy expansion of the system by adding new AC one-phase or three-phase components.

AC bus topology is not yet widespread, but could offer some gains in the objective of interconnection of subsystems and local/micro grids, in the frame of a future distributed power generation.

The aim of this paper is to compare the operational performance systems based on an AC or a DC bus. Two model systems are considered with the same components but with different bus topology.

*Paper accepted for presentation at the 3rd Mediterranean Conference and Exhibition on Power Generation, Transmission, Distribution and Energy Conversion MED POWER 2002, jointly organized by National Technical University of Athens, IEE Hellas, Israel and Cyprus, Athens, Greece, November 4-6, 2002*

## II. AC BUS VERSUS DC BUS CONCEPTS

In this Paragraph, the AC and DC bus concepts are introduced. An AC bus system is based on a special battery inverter; this battery inverter (called hereafter "*AC island inverter*") is reversible and able to form the grid in the DC→AC direction of the inverter as well as in the AC→DC direction of the charger. The generating units have to provide an AC current synchronised to this small grid.

In particular, a PV array needs a special PV inverter (called hereafter "*PV grid inverter*") for grid-connected application. The PV grid inverter operates in parallel with the battery inverter or is synchronised to the grid and disposes an MPPT function.

On the other hand, the generating units in a DC bus system are connected to the DC battery voltage level, while a common central battery inverter (called hereafter "*DC central inverter*") is necessary to provide the standard power to the AC loads.

Figure 1 illustrates a typical configuration of a hybrid system with an AC bus topology used here as a case-study. This schema represents a real system installed on the Island of Kythnos in Greece. This system feeds typical domestic loads as well as an irrigation pump. Both types of load represent the general case of a domestic load and a dispatchable one. Figure 2 shows an alternative topology containing similar modules but based on the DC principle. The analysis in this paper is based on the comparison of these two models systems.

Under the objective to choose a system with optimal performance in terms of reliability, losses, loss of load and economies, it is necessary to study the influence of the chosen topology. For this purpose emphasis is given to the selection of appropriate models for the various components that can be applied in both cases; for modelling systems with AC or DC bus. This methodology permits to extract clear conclusions on the influence of the bus-type.

## III. SYSTEM AND COMPONENTS MODELLING

### A. Short review of general models

Since the objective is to study the influence of the bus type on the long-term performance of the system, the models chosen for the various components are steady-state ones. The various models were integrated in the form of "blocks" in a modular simulation software. The modularity of the developed tool permits to simulate easily configurations based either on AC or DC bus. Given the steady-state nature of the models, the simulation algorithm focuses on the balance of both active and reactive power based on a

method chosen previously for the case of AC connected components [2].

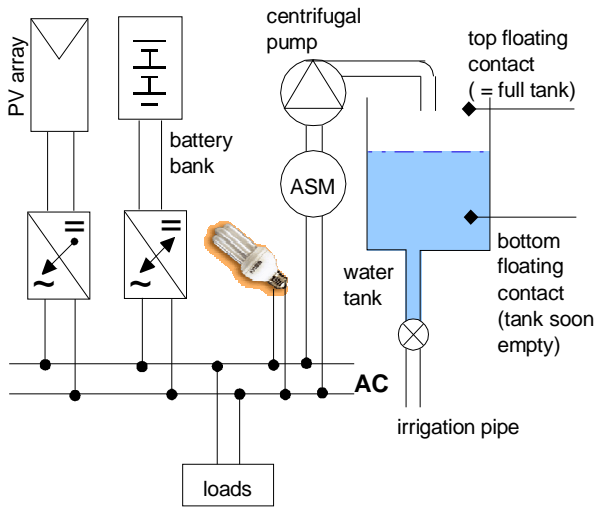

Figure 1: Circuit of the pilot AC bus PV pumping system of Kythnos

The photovoltaic array is modelled with the classical one-diode electric equivalent scheme, which takes into account both solar irradiance and cell junction temperature to calculate current-voltage characteristic [3].

In the developed software, a battery model [4] accounting for sharply increasing voltage during gassing phase was used. This is because the implemented operation control strategies force periodically the battery to have gassing for maintenance reasons.

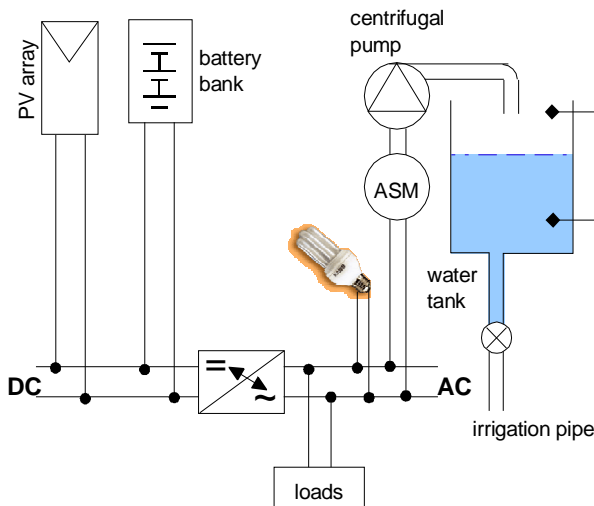

Figure 2: PV pumping system with a DC bus topology

For the needs of the particular application, a detailed model was developed for the water pump appropriate for estimating accurately the operating point of the system [6].

### B. Inverter: device choice and modelling

The comparison in this paper focuses only on the topology.

Thus, in order to perform a rigorous comparison, it is desirable to use identical devices in both topologies so as to eliminate as far as possible the influence of the inverter's efficiency. The aim is thus, to use the same reversible device able to operate, either as an AC island inverter, or as a DC central inverter.

The AC island inverter shown in Figure 1 is not a good candidate because it does not include an input for direct connection of the PV array to the battery. Thus, it cannot be used as a DC central inverter.

On the other hand, three DC central inverters were tested to check their possible capability to operate when a PV grid inverter was connected on the AC output side. Their efficiency in both directions inverter and charger could be measured with different combinations of ohmic and inductive loads. These measurements of the actual devices' have permitted to identify the parameters of the model: this model gives the DC side power  $P_{DC}$  as a function of the active power  $P_{AC}$  and the apparent power  $S_{AC}$ :

- in the inverter direction (sign convention  $P_{AC} < 0$ ):

$$P_{DC} = P_{AC} + o_0 + o_1 \cdot P_{AC} + o_2 \cdot P_{AC}^2 + o_3 \cdot S_{AC} + o_4 \cdot S_{AC}^2$$

where  $o_0, o_1, o_2, o_3$  and  $o_4$  are the model parameters

- in the charger direction (sign convention  $P_{AC} > 0$ ):

$$P_{DC} = P_{AC} - c_0 - c_1 \cdot P_{AC} - c_2 \cdot P_{AC}^2 - c_3 \cdot S_{AC} - c_4 \cdot S_{AC}^2$$

where  $c_0, c_1, c_2, c_3$  and  $c_4$  are the model parameters

This model was initially selected for the AC bus calculations, because it takes the AC power as input, which is the exchange value between the AC modular components. The model offers nevertheless the advantage to be usable both with the DC bus, as well as with the AC bus system configurations. This possibility contributes to keep the modular character of the simulation tool.

### C. Implementation and inputs

The modular software was implemented under Matlab Simulink environment. Each component is represented by a block. Balance of both active and reactive power is calculated based on a method chosen previously for the case of AC connected components [2].

Timeseries of either synthetic or real solar radiation and load data are necessary for running simulations. The anisotropic radiation model [5] known as "HDKR model" was used to convert horizontal values of solar radiation to tilted values. Figure 3 gives a view of the graphical program.

## IV. CASE-STUDIES

### A. Characteristics of the actual system

The studied single-phase PV system was set up in spring 2001 in the frame of a European project in Greece, on the island of Kythnos. This system is used by a farmer to run a water pump for irrigation purposes, and to provide electricity for other loads, such as light and a machine for honey extraction.

The only power source is a 2.16 kWp photovoltaic array coupled to a 2 kW PV grid inverter. The 3.3 kW battery

inverter is an AC island inverter connected to a 60 V, 490 Ah lead–acid battery. The water pump is coupled to a tank of 15 m<sup>3</sup>; this water storage enables the pump to be run

at its rated flow rate during a short time while the drip–irrigation distributes the pumped water at a low flow rate all along the day.

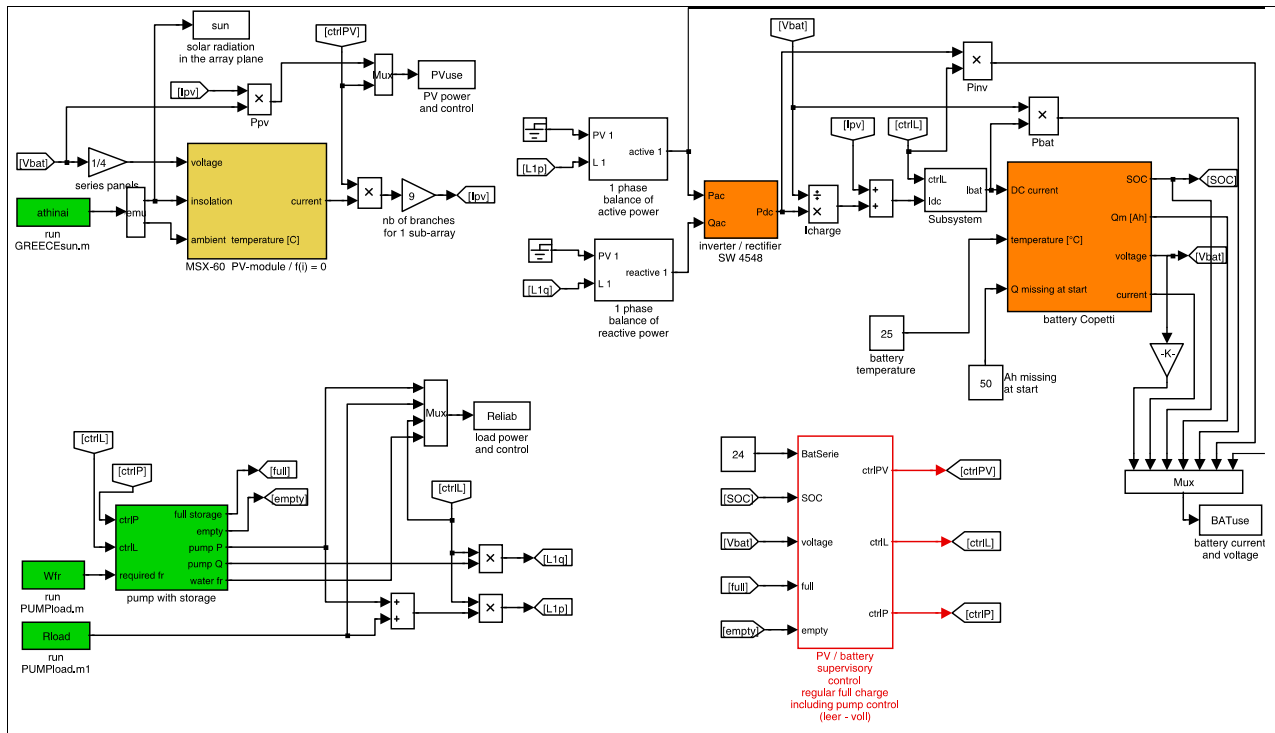

Figure 3: Graphical view of the modular simulation tool

The aim of developing this pilot PV system was to demonstrate in a small scale the feasibility of the concept of an AC bus. Although in the mid–term (several years) it can be feasible to interconnect several such small AC systems from the island of Kythnos, the actual system operates at present in a stand–alone mode. The AC bus topology presents the major drawback that the produced PV energy flows through two inverters, while the direct connection between photovoltaic and battery would be the natural solution.

As a consequence, it could have been replaced by a system with the most widespread topology, without PV inverter, using a common DC central inverter, as shown in Figure 2. It is consequently of interest to compare the operational performance (in terms of reliability of loads supply and AC↔DC conversion losses) of the initial system and the DC bus system.

### B. Configuration of the simulation tool

As explained in the previous Section, three specific types of DC central inverters are used in both model systems due to their capacity to operate in both topologies. Given their difference with the inverter installed at the real system of Kythnos, some assumptions are needed for the configuration of the AC–bus model system. The DC central inverters work with a 48 V battery voltage. However, in the AC bus topology of the Kythnos system, the PV array is

arranged in 2 strings of 18 series–connected modules in order to match the input voltage of the PV grid inverter. Thus, the PV generator is assumed to be connected in strings of 4 series–connected modules so as to match the battery voltage. The PV array topology 18 series / 2 parallel is thus rearranged into a 4 series / 9 parallel topology, in order to keep a 36–modules array in both cases. Similarly, instead of considering the 60 V–battery of the actual system of Kythnos, a 48 V–battery of the same energetic capacity is considered :

- real battery : 490 Ah × 60 V = 29,4 kWh
- model battery : 612,5 Ah × 48 V = 29,4 kWh

### C. Operation scenarios

The examined system of Kythnos provides power for two kinds of load: the usual domestic loads having a specific load profile, as well as the supply of the pump. Due to the existence of water storage, the demand for pumping is indeed dispatchable and can be different from the water demand profile. The daily water demand reaches 12 m<sup>3</sup> at the most; the pump running at its rated power delivers this quantity in only two hours. Hence, we can quite freely choose the time at which the pump should be run along the day.

In all cases, the pump is stopped when the tank is full, and the supply of any load is forbidden when SOC<0.4 (SOC is the battery state of charge) so as to protect the battery from

a deep discharge. It means that it makes possible to run the simulations with different load management strategies, i.e. choose the time at which the pump is started, and the priority of the deferrable pump compared to the other loads. A detailed analysis of the operational performance of different strategies for load and storage management is presented in [6].

Four different combinations of strategies and sizes of both electricity and water storage were chosen as shown in Table 1.

	configur. 1	configur. 2	configur. 3	configur. 4
battery capacity	490 Ah	250 Ah	300 Ah	350 Ah
tank volume	15 m <sup>3</sup>	30 m <sup>3</sup>	25 m <sup>3</sup>	50 m <sup>3</sup>
pump start	clock 11:00	empty tank	empty tank	empty tank
pump run allowed	SOC > 0.4	SOC > 0.5	SOC > 0.4	SOC > 0.5
(name of strategy)	(strategy 2)	(strategy 4)	(strategy 3)	(strategy 4)

Table 1: Studied configurations in pump management and storages

These 4 scenarios have been simulated with both AC bus and DC bus topology. Three alternative DC central inverters are used having the nominal power shown in Table 2. These inverters are able to operate, either as AC island inverter, or as DC central inverter.

designation code	nominal power
B	4500 VA
C	3500 VA
D	3000 VA

Table 2: Nominal power of the inverters

In the case of the PV pumping system using an AC bus topology, a permanent operation of the inverter is required to maintain the grid. However, in the case of a DC bus topology, the same inverter is able to operate in stand-by mode, in order to avoid the non negligible no-load losses (from 14 to 44 W, depending on the inverter).

For this reason, the influence of the stand-by operation mode on the long-term performance is also studied.

Calculations were carried out for a time period of one year with a 10-minutes simulation time step, using linear interpolation to convert the hourly meteorological inputs.

## V. RESULTS

Figure 4 shows the reliability of supply of the two kinds of loads, for each one of the four scenarios and as a function of the inverter choice and the possible use of the stand-by operation mode.

The calculations showed that the reliability results are at least as good with a DC bus topology using the stand-by function as with an AC bus topology. Moreover, the DC bus topology offers an energy benefit in some cases. Nevertheless, the results with a DC bus can be worse if the stand-by function of the inverter is not activated.

Reliability in DC bus depending on configuration and inverter

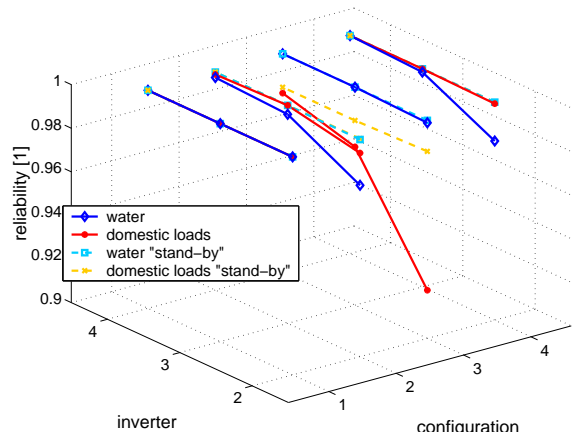

Figure 4: Reliability of both loads with and without use of stand-by function

The 3<sup>rd</sup> strategy of load management was found in the previous study [6] to be the most sensible. The use of the stand-by function is essential, because the annual reliability raises by 6% compared to the case where the stand-by operation mode was not chosen. Nevertheless this benefit is only noteworthy with the inverter B, which has a no-load consumption about 2 times higher than the one of the inverters C and D.

The difference is explained by the magnitude of the inverter losses. Figure 5 shows the annual conversion losses of the three inverters for each one of the four scenarios.

Losses in DC bus depending on configuration and inverter

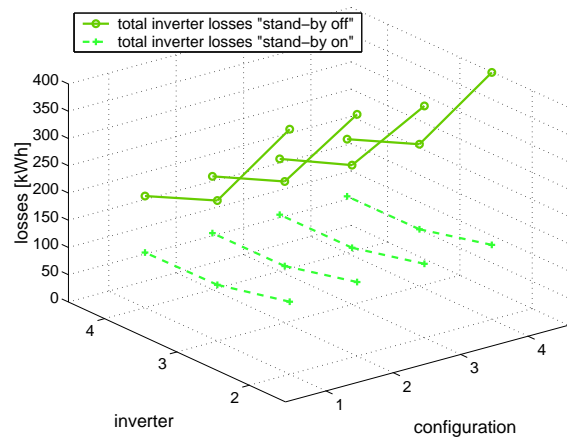

Figure 5: Annual losses of the 3 inverters

Figure 5 shows clearly that the use of the stand-by function allows the losses to be of the same size for the 3 inverters. On the contrary, the permanent operation penalizes clearly the inverter B.

We come now to the comparison of operational performance between AC bus and DC bus; Figure 6 and Figure 7 show the annual reliability of each kind of load :

The pictures show that the difference of performance between AC and DC bus is limited in the majority of cases. For some configurations tested outside the frame of this study, especially system configurations with a smaller capacity of the battery, the use of the DC bus topology

allowed the loads of these critical systems to receive 1% more kWh than with an AC bus topology.

Reliability of domestic loads supply according to the topology

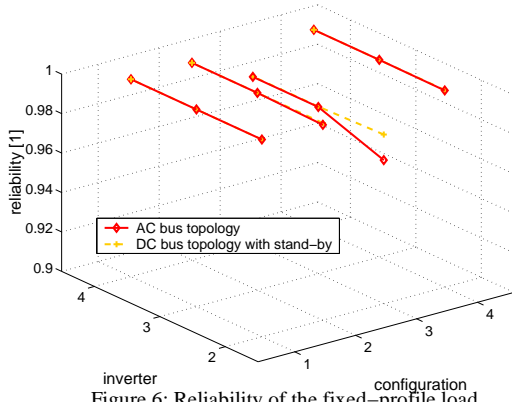

Figure 6: Reliability of the fixed-profile load

Reliability of water supply according to the topology

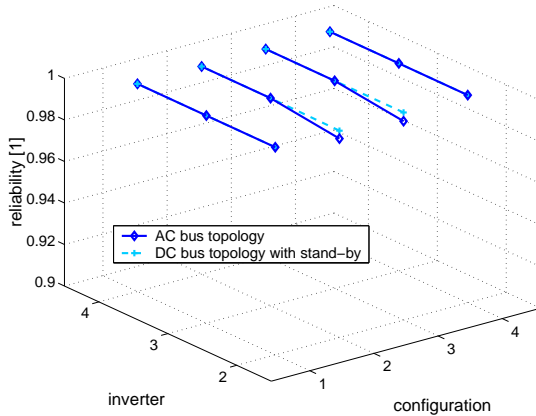

Figure 7: Reliability of the deferrable load (water pump)

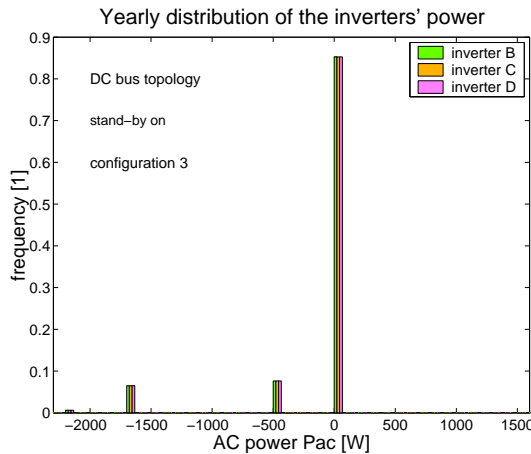

Figure 8: Distribution of inverters' operation power in DC bus topology

Figure 8 depicts the annual distribution of drawn power from the three types of inverters (B, C, D) in DC bus topology. In contrast to the AC bus topology, only power consumers are connected on the AC side of inverters, hence the distribution shows only negative values. Figure 9 shows the distribution of corresponding losses.

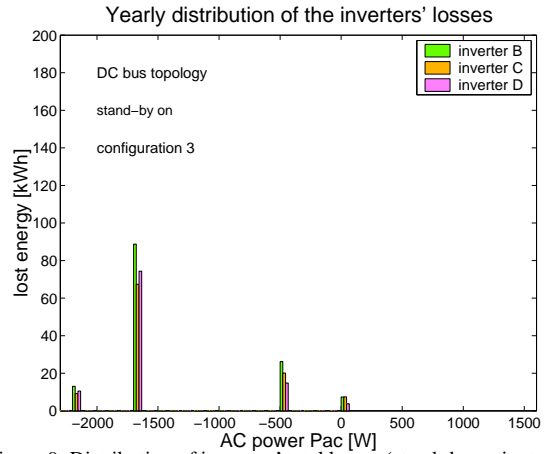

Figure 9: Distribution of inverters' total losses (stand-by activated)

Finally, it is noted that the DC central inverters used for this study do not include a MPPT, contrary to the PV grid inverter of Kythnos. The lack of a MPPT implies a lower performance. In order to quantify this issue, the simulation results were analysed, to calculate the available energy to this system equipped with 2.16 kWp PV generator using sun radiation conditions of Greece. The following results were found:

- AC bus topology (AC power available to the AC bus) : at the output of the PV grid inverter, because of the MPPT, the available energy is 3156 kWh/year in all cases
- DC bus topology (DC power available to the DC bus) : at the output of the PV generator, because of the dependance of the operation point of the modules with the battery voltage, the available energy is  $3090 \pm 0,3\%$  kWh/an (calculated as average of the 4 configurations studied)

This represents a loss of 2,1% unfavourable to the DC bus. But the difference of 66 kWh is offset by the energy saving due to the inverter total losses varying from 135 to 260 kWh according to the device. This difference, favourable to the DC bus, is due to the possibility to use the stand-by function.

## VI. CONCLUSION AND OUTLOOK

The concept of AC bus hybrid systems, still under development, presents the advantage of giving the possibility to connect to the same standard energy bus multiple components of power generation and consumption. The analysis of the considered case study shows no particular advantage of operational performance for AC or DC bus. Hence, the only difference, which can be noticeable, is at the economic level. For a given system size, the cost depends on the topology and the distance between the PV generator and the battery. In the previous simulations it was assumed that the PV array was very close to the battery, so the cable losses could be neglected. If some distance is added, we consider having identical cable losses whatever energy bus, so that the topology comparison makes sense.

If we choose to use an AC topology, the system cost will increase by the cost of the PV grid inverter. But if we choose a DC topology, we will have to increase the cable section because of the lower voltage (about 50 V instead of 230 V). The cost difference cannot be neglected, because the cables section has to be about 21 times bigger (proportional to the square of currents ratio).

As shown in Figure 10, the difference of costs between AC and DC systems are expressed as:

$$\Delta C_{AC} = C_{PVinv} + C_c \times d$$

$$\Delta C_{DC} = 21 \times C_c \times d$$

where:

$d$  is the distance between PV array and battery and,  
 $C_c$  is the reference cost of 1 unit length of cable (sized adequately for the AC voltage level)

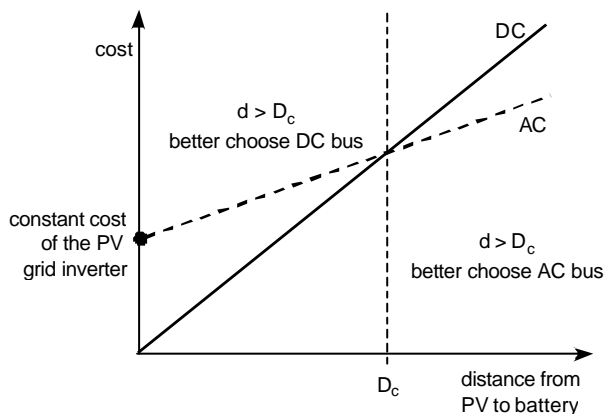

Figure 10: Cost comparison of topologies in function of PV array distance.

As a consequence, it is possible to define a new choice criterion, the critical distance  $D_c$ . The criterion leads to choose a DC bus topology if the PV array is locally situated, and the AC bus topology for a remote PV array.

In a future with high penetration of distributed power generators, the AC bus concept would obviously be an advantage, because it allows all AC modular components to be connected on the same energy bus.

On the other hand, if we think in terms of interconnected subsystems, it has no importance if energy is exchanged inside the subsystem through a DC or AC bus. The only requirement is that each subsystem exchanges energy with the others through AC buses.

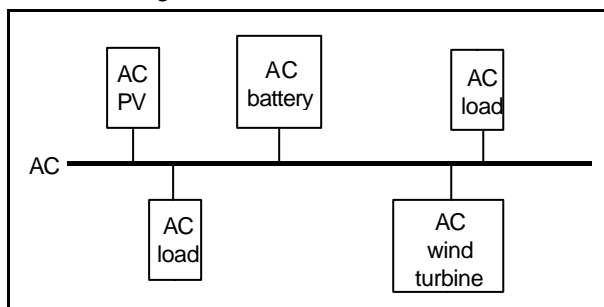

Figure 11: Connection of distributed AC modular components

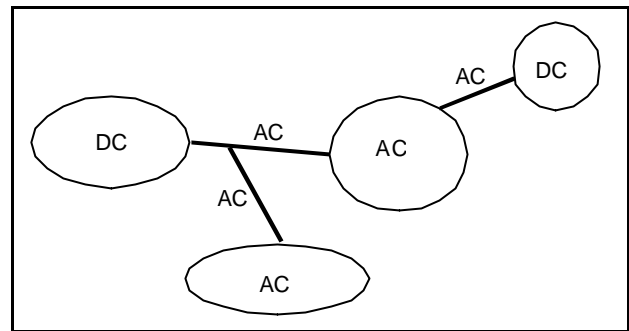

Figure 12: Interconnection of distributed sub-systems.

## ACKNOWLEDGEMENTS

This work was partially performed in the frame of the European Commission partially funded project PV MODE (MODular stand-alone PV plants for Decentralised Electrification), contract JOR3-CT98-0244, coordinated by the German institute for the solar energy technology ISET (Institut für Solarenergieversorgungstechnik).

## REFERENCES

- [1] Ph. Strauss, B. Burger, P. Funtan, W. Kleinkauf, O. Haas, "PVHybrid Systems and Micro Grids with New Standard Power Components", Photovoltaic Hybrid Power Systems Conference, Aix, France, 7-8 September 2000
- [2] Ph. Strauss, R.-P. Wurtz, O. Haas, M. Ibrahim, "Stand-Alone AC/PV Systems and Micro Grids with New Standard Power Components - First Results of Two European Joule Projects 'PV-MODE' and 'MORE' ", 16th European Photovoltaic Solar Energy Conference, Glasgow, Great Britain, 1-5 May 2000
- [3] Performance analysis of Photovoltaic Energy Systems, PhD thesis, Angèle Reinders, Universiteit Utrecht, 1999
- [4] "A General Battery Model for PV System Simulation", J. B. Copetti, E. Lorenzo, F. Chenlo, Progress in Photovoltaics : research and applications, Vol. 1, 1993
- [5] Solar Engineering of Thermal Processes, J. A. Duffie, W. M. Beckman, 2nd edition, Wiley, New York, 1991
- [6] Relationship Between Operation Strategies and Sizing in a Stand-Alone PV System Feeding a Water Pump, C. Trousseau, P. Funtan, Ph. Strauss, 17th European Photovoltaic Solar Energy Conference, Munich, Germany, 22-26 October 2001

## BIOGRAPHIES

Céline Trousseau was born in Champigny, France in 1972. She received her MSc in applied Physics from the University of Lyon in 1996 and the Diploma of Advanced Studies in Energetics from the University of Nice in 1997. She has been working since 1998 towards a Ph.D. degree at the center for the energy research of the École des Mines de Paris. Her research interests are energy management in hybrid systems, renewable energies and global energy issues.

Georges Kariniotakis was born in Athens, Greece in 1967. He received his production and management engineering and MSc degrees from the Technical University of Crete, Greece and his PhD degree from Ecole des Mines de Paris in 1996. He is currently working with the Center of Energy Studies of Ecole des Mines de Paris as a scientific project manager. He is a member of IEEE. His research interests include renewable energies, distributed generation, artificial intelligence and others.